

# CONTROL VALVE HANDBOOK

Fifth Edition



**EMERSON**<sup>TM</sup>

---

**FISHER**<sup>TM</sup>

## **Emerson Automation Solutions**

### Flow Controls

Marshalltown, Iowa 50158 USA

Sorocaba, 18087 Brazil

Cernay, 68700 France

Dubai, United Arab Emirates

Singapore 128461 Singapore

Neither Emerson, Emerson Automation Solutions, nor any of their affiliated entities assumes responsibility for the selection, use or maintenance of any product. Responsibility for proper selection, use, and maintenance of any product remains solely with the purchaser and end user.

The contents of this publication are presented for informational purposes only, and while every effort has been made to ensure their accuracy, they are not to be construed as warranties or guarantees, express or implied, regarding the products or services described herein or their use or applicability. All sales are governed by our terms and conditions, which are available upon request. We reserve the right to modify or improve the designs or specifications of such products at any time without notice.

Fisher is a mark owned by one of the companies in the Emerson Automation Solutions business unit of Emerson Electric Co. Emerson and the Emerson logo are trademarks and service marks of Emerson Electric Co. All other marks are the property of their respective owners.

© 2005, 2019 Fisher Controls International LLC. All rights reserved.

D101881X012/ Sept19

## Preface

Control valves are an increasingly vital component of modern manufacturing around the world. Properly selected and maintained control valves increase efficiency, safety, profitability, and ecology.

The Control Valve Handbook has been a primary reference since its first printing in 1965. This fifth edition presents vital information on control valve performance and the latest technologies.

**Chapter 1** offers an introduction to control valves, including definitions for common control valve and instrumentation terminology.

**Chapter 2** develops the vital topic of control valve performance.

**Chapter 3** covers valve and actuator types.

**Chapter 4** describes digital valve controllers, analog positioners, boosters, and other control valve accessories.

**Chapter 5** is a comprehensive guide to selecting the best control valve for an application.

**Chapter 6** addresses the selection and use of special control valves.

**Chapter 7** explains desuperheaters, steam conditioning valves, and turbine bypass systems.

**Chapter 8** details typical control valve installation and maintenance procedures.

**Chapter 9** contains information on control valve standards and approval agencies across the world.

**Chapter 10** identifies isolation valves and actuators.

**Chapter 11** covers discrete automation.

**Chapter 12** discusses various process safety instrumented systems.

**Chapter 13** provides useful tables of engineering reference data.

**Chapter 14** includes piping reference data.

**Chapter 15** is a handy resource for common conversions.

The Control Valve Handbook is both a textbook and a reference on the strongest link in the control loop: the control valve and its accessories. This book includes extensive and proven knowledge from leading experts in the process control field, including contributions from the ISA.

# Table of Contents



<b>Chapter 1: Introduction to Control Valves .....</b>	<b>14</b>
1.1 What is a Control Valve? .....	15
1.2 Sliding-Stem Control Valve Terminology .....	15
1.3 Rotary Control Valve Terminology .....	21
1.4 Control Valve Functions and Characteristics Terminology.....	23
1.5 Process Control Terminology.....	25
<b>Chapter 2: Control Valve Performance .....</b>	<b>32</b>
2.1 Process Variability .....	33
2.1.1 Deadband.....	35
2.1.1.1 Causes of Deadband.....	35
2.1.1.2 Effects of Deadband .....	36
2.1.1.3 Performance Tests.....	36
2.1.1.4 Friction .....	36
2.1.2 Actuator and Positioner Design .....	37
2.1.3 Valve Response Time.....	38
2.1.3.1 Dead Time .....	38
2.1.3.2 Dynamic Time.....	38
2.1.3.3 Solutions.....	39
2.1.3.4 Supply Pressure.....	40
2.1.3.5 Minimizing Dead Time .....	40
2.1.3.6 Valve Response Time .....	41
2.1.4 Valve Type and Characterization.....	41
2.1.4.1 Installed Gain.....	43
2.1.4.2 Loop Gain .....	43
2.1.4.3 Process Optimization .....	44
2.1.5 Valve Sizing.....	45
2.2 Economic Results .....	46
2.3 Summary .....	48
<b>Chapter 3: Valve and Actuator Types .....</b>	<b>50</b>
3.1 Control Valve Styles .....	51
3.1.1 Globe Valves .....	51
3.1.1.1 Single-Port Valve Bodies .....	51
3.1.1.2 Post- and Port-Guided Valve Bodies.....	52
3.1.1.3 Cage-Style Valve Bodies .....	52
3.1.1.4 Double-Ported Valve Bodies.....	53
3.1.1.5 Three-Way Valve Bodies.....	53
3.1.2 Sanitary Valves .....	54
3.1.3 Rotary Valves .....	54
3.1.3.1 Butterfly Valve Bodies .....	54
3.1.3.2 Segmented Ball Valve Bodies .....	55

3.1.3.3 High-Performance Butterfly Valve Bodies .....	55
3.1.3.4 Eccentric Plug Valve Bodies .....	56
3.1.3.5 Full-Port Ball Valve Bodies .....	57
3.1.3.6 Multi-Port Flow Selector .....	57
3.2 Control Valve End Connections .....	57
3.2.1 Screwed Pipe Threads .....	57
3.2.2 Bolted Gasketed Flanges.....	58
3.2.3 Welded End Connections.....	58
3.2.4 Other Valve End Connections .....	59
3.3 Valve Body Bonnets.....	59
3.3.1 Extension Bonnets.....	60
3.3.2 Bellows Seal Bonnets.....	61
3.4 Control Valve Packing.....	61
3.4.1 PTFE V-Ring.....	62
3.4.2 Laminated and Filament Graphite .....	62
3.4.3 U.S. Regulatory Requirements for Fugitive Emissions .....	62
3.4.4 Global Standards for Fugitive Emissions.....	63
3.4.5 Single PTFE V-Ring Packing.....	65
3.4.6 ENVIRO-SEAL PTFE Packing.....	65
3.4.7 ENVIRO-SEAL Duplex Packing .....	67
3.4.8 ISO-Seal PTFE Packing .....	67
3.4.9 ENVIRO-SEAL Graphite ULF.....	67
3.4.10 HIGH-SEAL Graphite ULF .....	67
3.4.11 ISO-Seal Graphite Packing.....	67
3.4.12 ENVIRO-SEAL Graphite for Rotary Valves.....	67
3.4.13 Graphite Ribbon for Rotary Valves .....	67
3.4.14 Sliding-Stem Environmental Packing Selection.....	67
3.4.15 Rotary Environmental Packing Selection.....	69
3.5 Characterization of Cage-Guided Valve Bodies .....	69
3.6 Valve Plug Guiding .....	70
3.7 Restricted-Capacity Control Valve Trim .....	70
3.8 Actuators .....	71
3.8.1 Diaphragm Actuators .....	71
3.8.2 Piston Actuators .....	72
3.8.4 Rack-and-Pinion Actuators.....	73
3.8.5 Electric Actuators.....	73
<b>Chapter 4: Control Valve Accessories .....</b>	<b>74</b>
4.1 Environmental & Application Considerations.....	75
4.2 Positioners .....	75
4.2.1 Pneumatic Positioners.....	75

4.2.2 Analog I/P Positioners .....	76
4.2.3 Digital Valve Controllers .....	77
4.2.3.1 Diagnostics .....	77
4.2.3.2 Two-Way Digital Communication .....	78
4.3 I/P Transducers .....	78
4.4 Volume Boosters .....	78
4.5 Safety Instrumented Systems (SIS) .....	80
4.5.1 Partial Stroke Testing .....	80
4.6 Controllers .....	81
4.7 Position Transmitters .....	83
4.8 Limit Switches .....	83
4.9 Solenoid Valves .....	83
4.10 Trip Systems .....	84
4.11 Handwheels .....	84
<b>Chapter 5: Control Valve Sizing .....</b>	<b>86</b>
5.1 Control Valve Dimensions .....	88
5.1.1 Face-to-Face Dimensions for Flanged, Globe-Style Valves .....	88
5.1.2 Face-to-Face Dimensions for Butt Weld-End, Globe-Style Valves .....	90
5.1.3 Face-to-Face Dimensions for Socket Weld-End, Globe-Style Valves .....	91
5.1.4 Face-to-Face Dimensions for Screwed-End, Globe-Style Valves .....	92
5.1.5 Face-to-Centerline Dimensions for Raised-Face, Globe-Style Angle Valves .....	92
5.1.6 Face-to-Face Dimensions for Separable Flange, Globe-Style Valves .....	93
5.1.7 Face-to-Face Dimensions for Flanged and Flangeless Rotary Valves .....	93
5.1.8 Face-to-Face Dimensions for Single Flange and Flangeless Butterfly Valves .....	94
5.1.9 Face-to-Face Dimensions for High-Pressure, Offset Butterfly Valves .....	94
5.2 Control Valve Seat Leakage Classifications .....	95
5.3 Class VI Maximum Seat Leakage Allowable .....	96
5.4 Control Valve Flow Characteristics .....	96
5.4.1 Flow Characteristics .....	96
5.4.2 Selection of Flow Characteristics .....	97
5.5 Valve Sizing .....	97
5.7 Equation Constants .....	99
5.8 Sizing Valves for Liquids .....	100
5.8.1 Determining Piping Geometry Factor and Liquid Pressure-Recovery Factor .....	100
5.8.2 Determining the Pressure Drop to Use for Sizing .....	101
5.8.3 Calculating the Required Flow Coefficient .....	101
5.8.4 Liquid Sizing Sample Problem .....	102
5.9 Sizing Valves for Compressible Fluids .....	104
5.9.1 Determining Piping Geometry Factor and Pressure Drop Ratio Factor at Choked Flow .....	105

5.9.2 Determining Pressure Drop Ratio to Use for Sizing and Expansion Factor.....	105
5.9.3 Calculating Flow Coefficient .....	105
5.9.4 Compressible Fluid Sizing Sample Problem No. 1 .....	106
5.9.5 Compressible Fluid Sizing Sample Problem No. 2 .....	107
5.10 Representative Sizing Coefficients .....	109
5.10.1 Representative Sizing Coefficients for Single-Ported, Globe-Style Valves.....	109
5.10.2 Representative Sizing Coefficients for Rotary Valves .....	110
5.11 Actuator Sizing.....	111
5.11.1 Globe Valves .....	111
5.11.1.1 Unbalance Force .....	111
5.11.1.2 Force to Provide Seat Load.....	112
5.11.1.3 Packing Friction.....	112
5.11.1.4 Additional Forces.....	112
5.11.2 Actuator Force Calculations .....	114
5.12 Actuator Sizing for Rotary Valves.....	114
5.12.1 Torque Equations.....	114
5.12.2 Breakout Torque .....	114
5.12.3 Dynamic Torque .....	114
5.13 Typical Rotary Valve Torque Factors.....	115
5.13.1 Torque Factors for V-Notch Ball Valve with Composition Seal.....	115
5.13.2 Torque Factors for Butterfly Valve with Composition Seal.....	115
5.13.2.1 Maximum Rotation .....	115
5.14 Cavitation and Flashing .....	116
5.14.1 Choked Flow Causes Flashing and Cavitation.....	116
5.14.2 Valve Selection for Flashing Service.....	117
5.14.3 Valve Selection for Cavitation Service .....	118
5.15 Noise Prediction.....	118
5.15.1 Aerodynamic .....	118
5.15.2 Hydrodynamic.....	120
5.16 Noise Control .....	120
5.17 Noise Summary .....	123
5.18 Packing Selection.....	124
5.18.1 Packing Selection Guidelines for Sliding-Stem Valves.....	125
5.18.2 Packing Selection Guidelines for Rotary Valves.....	126
5.19 Valve Body Materials .....	127
5.19.1 Designations for Common Valve Body Materials.....	129
5.20 Pressure-Temperature Ratings .....	130
5.20.1 Standard Class ASTM A216 Grade WCC Cast Valves .....	130
5.20.2 Standard Class ASTM A217 Grade WC9 Cast Valves .....	131
5.20.3 Standard Class ASTM A351 Grade CF3 Cast Valves.....	132
5.20.4 Standard Class ASTM A351 Grades CF8M and CG8M Valves.....	133



5.21 Non-Metallic Material Abbreviations .....	135
5.22 Non-Destructive Test Procedures .....	135
5.22.1 <i>Magnetic Particle (Surface) Examination</i> .....	135
5.22.2 <i>Liquid Penetrant (Surface) Examination</i> .....	136
5.22.3 <i>Radiographic (Volumetric) Examination</i> .....	136
5.22.4 <i>Ultrasonic (Volumetric) Examination</i> .....	136
<b>Chapte 6: Special Control Valves .....</b>	<b>138</b>
6.1 High-Capacity Control Valves .....	139
6.2 Low-Flow Control Valves .....	140
6.3 High-Temperature Control Valves .....	140
6.4 Cryogenic Service Valves .....	141
6.5 Valves Subjected to Cavitation and Fluids with Particulate .....	141
6.6 Customized Characteristics, Noise-Abatement, and Cavitation-Mitigation Trims .....	142
6.7 Control Valves for Nuclear Service in the U.S. ....	142
6.8 Valves Subjected to Sulfide Stress Cracking .....	143
6.8.1 <i>Pre-2003 Revisions of NACE MR0175</i> .....	143
6.8.2 <i>NACE MR0175/ISO 15156</i> .....	144
6.8.3 <i>NACE MR0103</i> .....	145
<b>Chapter 7: Steam Conditioning .....</b>	<b>146</b>
7.1 Understanding Desuperheating .....	147
7.1.1 <i>Technical Aspects of Desuperheating</i> .....	147
7.2 Typical Desuperheater Designs .....	150
7.2.1 <i>Fixed-Geometry Nozzle Design</i> .....	150
7.2.2 <i>Variable-Geometry Nozzle Design</i> .....	151
7.2.3 <i>Self-Contained Design</i> .....	151
7.2.5 <i>Geometry-Assisted Wafer Design</i> .....	152
7.3 Understanding Steam Conditioning Valves .....	153
7.4 Steam Conditioning Valves .....	153
7.4.1 <i>Steam Attenuator</i> .....	155
7.4.2 <i>Steam Sparger</i> .....	155
7.6 Turbine Bypass System Components .....	156
7.6.1 <i>Turbine Bypass Valves</i> .....	156
7.6.2 <i>Turbine Bypass Water Control Valves</i> .....	156
7.6.3 <i>Actuation</i> .....	157
<b>Chapter 8: Installation and Maintenance .....</b>	<b>158</b>
8.1 Proper Storage and Protection .....	159

8.2 Proper Installation Techniques .....	159
8.2.1 Read the Instruction Manual .....	159
8.2.2 Be Sure the Pipeline Is Clean .....	159
8.2.4 Use Good Piping Practices .....	160
8.2.5 Flushing/Hydro/Start-Up Trim .....	161
8.3 Control Valve Maintenance.....	161
8.3.1 Reactive Maintenance .....	162
8.3.2 Preventive Maintenance .....	162
8.3.3 Predictive Maintenance .....	162
8.3.4 Using Control Valve Diagnostics .....	162
8.3.4.1 Instrument Air Leakage .....	163
8.3.4.2 Supply Pressure .....	163
8.3.4.3 Travel Deviation and Relay Adjustment .....	163
8.3.4.4 Instrument Air Quality.....	164
8.3.4.5 In-Service Friction and Friction Trending.....	164
8.3.4.6 Other Examples.....	164
8.3.5 Continued Diagnostics Development.....	164
8.4 Service and Repair Parts .....	165
8.4.1 Recommended Spare Parts .....	165
8.4.2 Using Original Equipment Manufacturers (OEM) Parts.....	165
8.4.3 Consider Upgrades for the Valve Trim .....	165
8.5 Actuator Maintenance.....	165
8.5.1 Spring-and-Diaphragm Actuators .....	165
8.5.2 Piston Actuators .....	166
8.5.3 Stem Packing .....	166
8.5.4 Seat Rings.....	166
8.5.4.1 Replacing Seat Rings .....	166
8.5.4.2 Connections: Plug-to-Stem, Ball-to-Shaft, and Disk-to-Shaft.....	167
8.5.5 Bench Set.....	167
8.5.6 Valve Travel.....	167
<b>Chapter 9: Standards and Approvals .....</b>	<b>168</b>
9.1 Control Valve Standards .....	169
9.1.1 American Petroleum Institute (API).....	169
9.1.2 American Society of Mechanical Engineers (ASME) .....	169
9.1.3 European Committee for Standardization (CEN).....	169
9.1.3.1 European Industrial Valve Standards.....	169
9.1.3.2 European Material Standards .....	170
9.1.3.3 European Flange Standards.....	170
9.1.4 Fluid Controls Institute (FCI) .....	170
9.1.5 Instrument Society of America (ISA) .....	170
9.1.6 International Electrotechnical Commission (IEC).....	171

9.1.7 Manufacturers Standardization Society (MSS).....	171
9.1.8 NACE International.....	171
9.2 Product Approvals for Hazardous (Classified) Locations.....	172
9.2.1 Hazardous Location Approvals and Definitions.....	172
9.3 Classification Systems .....	172
9.3.1 Class/Division System.....	172
9.3.2 Zone System .....	173
9.3.3 Equipment Groups .....	174
9.3.4 Equipment Subgroups.....	174
9.3.4.1 Group II (Commonly referred to as the “Gas Group”).....	174
9.3.4.2 Group III (Commonly referred to as the “Dust Group”) .....	174
9.3.5 Type of Protection .....	175
9.3.5.1 Electrical Equipment.....	175
9.3.5.2 Non-Electrical Equipment .....	176
9.3.6 Level of Protection.....	177
9.3.7 Equipment Protection Level (EPL).....	177
9.4 Temperature Code .....	178
9.5 Nomenclature.....	179
9.5.1 Class/Division System.....	179
9.5.2 Zone System .....	179
9.5.3 Wiring Practices.....	179
9.5.4 European Union (EU) – ATEX Directive 2014/34/EU .....	180
9.6 Protection Techniques and Methods .....	181
9.6.1 Explosion-Proof or Flame-Proof Technique.....	181
9.6.2 Intrinsically-Safe Technique.....	181
9.6.3 Non-Incendive or Type n Technique.....	182
9.6.4 Increased Safety.....	182
9.6.5 Dust Ignition-Proof or Enclosure Dust-Proof.....	183
9.7 Enclosure Ratings.....	183
<b>Chapter 10: Isolation Valves .....</b>	<b>186</b>
10.1 Basic Valve Types.....	187
10.1.1 Gate Valves.....	187
10.1.2 Globe Valves .....	188
10.1.3 Check Valves .....	191
10.1.4 Bypass Valves.....	192
10.1.6 Pinch Valves.....	193
10.1.7 Ball Valves.....	194
10.1.8 Butterfly Valves .....	194
10.1.9 Plug Valves.....	195

<b>Chapter 11: Solenoid Valves.....</b>	<b>210</b>
11.1 Solenoid Valves .....	211
<b>Chapter 12: Safety Instrumented Systems.....</b>	<b>214</b>
12.1 Safety and Layers of Protection .....	215
12.2 Safety Instrumented Systems (SIS) .....	216
12.3 Safety Standards .....	217
12.4 Safety Integrity Level (SIL) .....	217
12.5 Probability of Failure Upon Demand .....	218
12.6 Final Elements, Proof Testing, and Partial Stroke Testing Techniques .....	219
12.7 Partial Stroke Testing .....	219
12.8 Online Testing Methods for the Final Element.....	220
12.9 Digital Valve Controller Use for Partial Stroke Testing .....	220
12.10 High-Integrity Pressure Protection System (HIPPS) .....	221
12.11 Functionality of the HIPPS .....	221
12.12 Testing Requirements .....	221
<b>Chapter 13: Engineering Data .....</b>	<b>224</b>
13.1 Standard Specifications for Pressure-Retaining Valve Materials.....	225
13.2 Valve Material Properties for Pressure-Containing Components .....	232
13.3 Physical Constants of Hydrocarbons.....	234
13.4 Specific Heat Ratio .....	237
13.5 Physical Constants of Various Fluids .....	238
13.6 Refrigerant 717 (Ammonia) Properties of Liquid and Saturated Vapor .....	240
13.7 Properties of Water .....	247
13.8 Properties of Saturated Steam.....	248
13.9 Properties of Superheated Steam .....	257
<b>Chapter 14: Pipe Data .....</b>	<b>266</b>
14.1 Pipe Engagement.....	267
14.2 Carbon and Alloy Steel - Stainless Steel.....	267
14.3 American Pipe Flange Dimensions.....	275
14.3.1 Diameter of Bolt Circles .....	275
14.3.2 Number of Stud Bolts and Diameter .....	276
14.3.3 Flange Diameter .....	277
14.3.4 Flange Thickness for Flange Fittings.....	278
14.4 Cast Steel Flange Standards.....	280
14.4.1 Cast Steel Flange Standard for PN 10.....	280
14.4.2 Cast Steel Flange Standard for PN 16.....	281

14.4.3 Cast Steel Flange Standard for PN 25 .....	282
14.4.4 Cast Steel Flange Standard for PN 40 .....	283
14.4.5 Cast Steel Flange Standard for PN 63 .....	284
14.4.6 Cast Steel Flange Standard for PN 100 .....	284
14.4.7 Cast Steel Flange Standard for PN 160 .....	285
14.4.8 Cast Steel Flange Standard for PN 250 .....	285
14.4.9 Cast Steel Flange Standard for PN 320 .....	286
14.4.10 Cast Steel Flange Standard for PN 400 .....	286

## **Chapter 15: Conversions and Equivalents..... 288**

15.1 Length Equivalents .....	289
15.2 Whole Inch to Millimeter Equivalents .....	289
15.3 Fractional Inch to Millimeter Equivalents .....	290
15.4 Additional Fractional Inch to Millimeter Equivalents .....	291
15.5 Area Equivalents.....	293
15.6 Volume Equivalents.....	293
15.7 Volume Rate Equivalents.....	293
15.8 Mass Conversion—Pounds to Kilograms .....	294
15.9 Pressure Equivalents .....	294
15.10 Pressure Conversion—Pounds Per Square Inch to Bar .....	295
15.11 Temperature Conversion Formulas.....	296
15.12 Temperature Conversions .....	296
15.13 API and Baumé Gravity Tables and Weight Factors .....	299
15.14 Other Useful Conversions.....	301
15.15 Metric Prefixes and Suffixes .....	302

## **Index..... 304**

# Chapter 1

## Introduction to Control Valves



## 1.1 What is a Control Valve?

Modern processing plants utilize a vast network of control loops to produce an end product for market. These control loops are designed to keep a process variable (i.e. pressure, flow, level, temperature, etc.) within a required operating range to ensure a quality end product is produced. Each of these loops receives and internally creates disturbances that detrimentally affect the process variable (PV). Interaction from other loops in the network also provide disturbances that influence the process variable. See Figure 1.1.

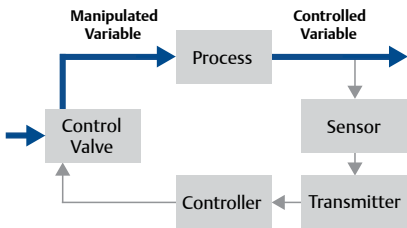

Figure 1.1 Feedback Control Loop

To reduce the effect of these load disturbances, sensors and transmitters collect information about the process variable (PV) and its relationship to some desired set point. A controller processes this information and decides what must be done to get the process variable back to where it should be after a load disturbance occurs. When all the measuring, comparing, and calculating are done, some type of final control element must implement the strategy selected by the controller.

The most common final control element in the process control industries is the control valve. The control valve manipulates a flowing fluid, such as gas, steam, water, or chemical compounds to compensate for the load disturbance and keep the regulated process variable as close as possible to the desired set point.

The control valve is a critical part of the control loop. Many people who talk about control valves are really referring to a control valve assembly. The control valve assembly typically consists of the valve body, the internal trim parts, an actuator to provide the motive power to operate the valve, and a variety of additional valve accessories, which can include, transducers, supply pressure regulators, manual operators, snubbers, or limit switches.

There are two main types of control valve designs, depending on the action of the closure member: sliding-stem or rotary. Sliding-stem valves, as seen in Figure 1.2 and 1.3, use linear motion to move a closure member into and out of a seating surface. Rotary valves, as seen in Figure 1.13 and 1.17, use rotational motion to turn a closure member into and out of a seating surface. ■

## 1.2 Sliding-Stem Control Valve Terminology

The following terminology applies to the physical and operating characteristics of standard sliding-stem control valves with diaphragm or piston actuators. Some of the terms, particularly those pertaining to actuators, are also appropriate for rotary control valves. Many of the definitions presented are in accordance with ANSI/ISA-75.05.01, Control Valve Terminology, although other popular terms are also included. Additional explanation is provided for some of the more complex terms. Additional sections in this chapter follow that define specific terminology for rotary control valves, general process control, and control valve functions and characteristics.



Figure 1.2 Sliding-Stem Control Valve

**Actuator Stem Force:** The net force from an actuator that is available for actual positioning of the valve plug, referred to as valve travel.

**Angle Valve:** A valve design in which the inlet and outlet ports are perpendicular to each other. See also Globe Valve.



Figure 1.4 Angle Valve

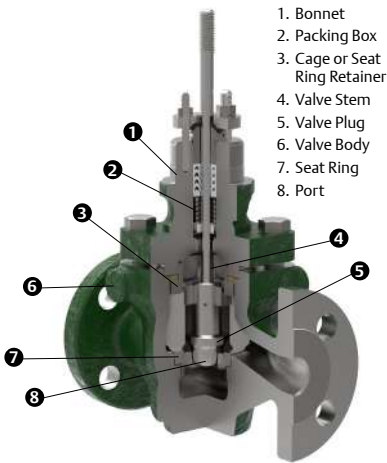

Figure 1.3 Sliding-Stem Control Valve

**Actuator Spring:** A spring, or group of springs, enclosed in the yoke or actuator casing or piston cylinder that moves the actuator stem in a direction opposite to that created by loading pressure.

**Actuator Stem:** The part that connects the actuator to the valve stem and transmits motion (force) from the actuator to the valve.

**Actuator Stem Extension:** An extension of the piston actuator stem to provide a means of transmitting piston motion to the valve positioner.

**Bellows Seal Bonnet:** A bonnet that uses a bellows for sealing against leakage around the closure member stem. See Figure 1.5.

**Bonnet:** The portion of the valve that contains the packing box and stem seal and can provide guiding for the valve stem. It provides the principal opening to the body cavity for assembly of internal parts or it can be an integral part of the valve body. It can also provide for the attachment of the actuator to the valve body. Typical bonnets are bolted, threaded, welded, pressure sealed, or integral with the body. This term is often used in referring to the bonnet and its included packing parts. More properly, this group of component parts should be called the bonnet assembly.

**Bonnet Assembly (Commonly Bonnet, more properly Bonnet Assembly):** An assembly including the part through which a valve stem moves and a means for sealing against leakage along the stem. It usually provides a means for mounting the actuator and loading the packing assembly, and maintains proper



alignment of the plug to the rest of the control valve assembly. See Figure 1.6.

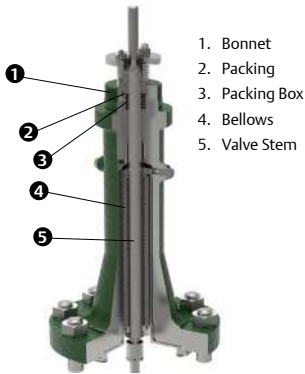

Figure 1.5 Bellows Seal Bonnet

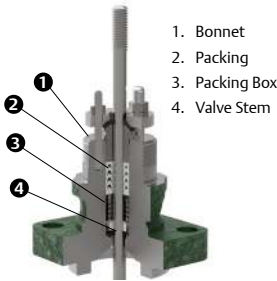

Figure 1.6 Bonnet Assembly

**Bottom Flange:** A part that closes a valve body opening opposite the bonnet opening. It can include a guide bushing and/or serve to allow reversal of the valve action.

**Bushing:** A device that supports and/or guides moving parts such as valve stems and plugs.

**Cage:** A part of the valve trim that

surrounds the closure member and can provide flow characterization and/or a seating surface. It also provides stability, guiding, balance, and alignment, and facilitates assembly of other parts of the valve trim. The walls of the cage contain openings that usually determine the flow characteristic of the control valve. See Figure 1.7.

**Closure Member:** The movable part of the valve that is positioned in the flow path to modulate the rate of flow through the valve.

**Closure Member Guide:** That portion of a closure member that aligns its movement in either a cage, seat ring (port guiding), bonnet, bottom flange, stem or any two of these.

**Cylinder:** The chamber of a piston actuator in which the piston moves.

**Cylinder Closure Seal:** The sealing element at the connection of the piston actuator cylinder to the yoke.

**Diaphragm:** A flexible, pressure responsive element that transmits force to the diaphragm plate and actuator stem.

**Diaphragm Actuator:** A fluid-powered device in which the fluid, usually compressed air (see Loading Pressure), acts upon a flexible component, the diaphragm to produce a force to move the closure member.

**Diaphragm Case:** A housing, consisting of top and bottom section, used for supporting a diaphragm and establishing one or two pressure chambers.



Figure 1.7 Cages (left to right): Linear, Equal-Percentage, Quick-Opening

**Diaphragm Plate:** A rigid plate concentric with the diaphragm for transmitting force to the actuator stem.

**Direct-Acting Actuator:** An actuator, in which the actuator stem extends with increasing loading pressure. See Figure 1.9.

**Extension Bonnet:** A bonnet with greater dimension between the packing box and bonnet flange for hot or cold service.



Figure 1.8 Three-Way Globe Valve

**Globe Valve:** A valve with a linear motion closure member, one or more ports, and a body distinguished by a globular shaped cavity around the port region. Globe valves can be further classified as: two-way single-ported (Figure 1.3); two-way double-ported; angle-style, or three-way (Figure 1.8).

**Loading Pressure:** Fluid, usually compressed air, applied to the diaphragm or piston in a pneumatic actuator.

**Offset Valve:** A valve construction having inlet and outlet line connections on different planes, but 180 degrees opposite each other.

**Packing Box (Assembly):** The part of the bonnet assembly used to seal against leakage around the closure member stem. Included in the complete packing box assembly are various combinations of some or all of the following component parts: packing,

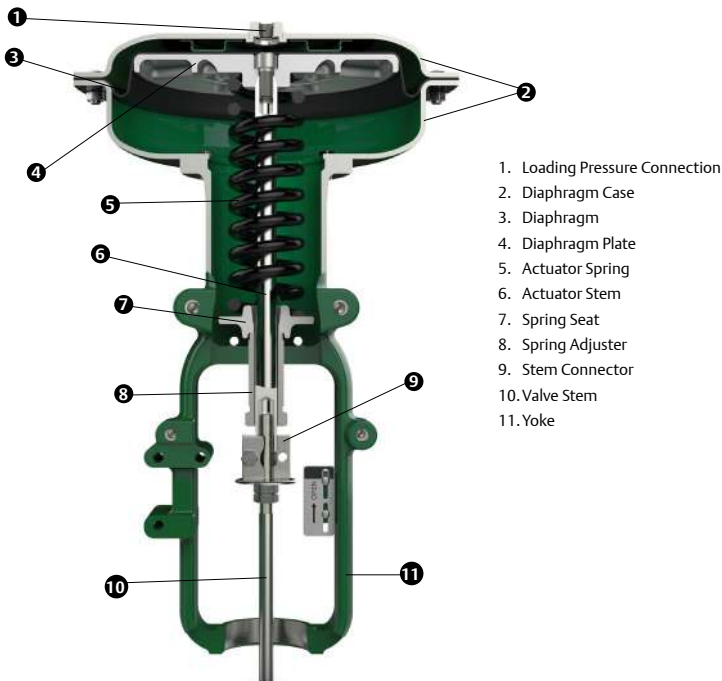

Figure 1.9 Direct-Acting Actuator

packing follower, packing nut, lantern ring, packing spring, packing flange, packing flange studs or bolts, packing flange nuts, packing ring, packing wiper ring, felt wiper ring, Belleville springs, anti-extrusion ring. See Figure 1.11.

**Piston:** A rigid movable pressure responsive element that transmits force to the piston actuator stem.



Figure 1.10 Piston-Type Actuator

**Piston-Type Actuator:** A fluid powered device in which the fluid, usually compressed air, acts upon a movable piston to provide motion of the actuator stem and provide seating force upon closure. Piston-type actuators are

classified as either double-acting, so that full power can be developed in either direction, or as spring-fail so that upon loss of supply power, the actuator moves the valve in the required direction of travel. See Figure 1.10.

**Port:** The flow control orifice of a control valve.

**Retaining Ring:** A split ring that is used to retain a separable flange on a valve body.

**Reverse-Acting Actuator:** An actuator in which the actuator stem retracts with increasing loading pressure. Reverse actuators have a seal bushing installed in the upper end of the yoke to prevent leakage of the loading pressure along the actuator stem. See Figure 1.12.

**Rubber Boot:** A protective device to prevent entrance of damaging foreign material into the piston actuator seal bushing.

**Seal Bushing:** Top and bottom bushings that provide a means of sealing the piston actuator cylinder against leakage. Synthetic rubber O-rings are used in the bushings to seal the cylinder, the actuator stem, and the actuator stem extension.

**Seat:** The area of contact between the closure member and its mating surface that establishes valve shutoff.

**Seat Load:** The net contact force between the closure member and seat with stated static conditions. In practice,

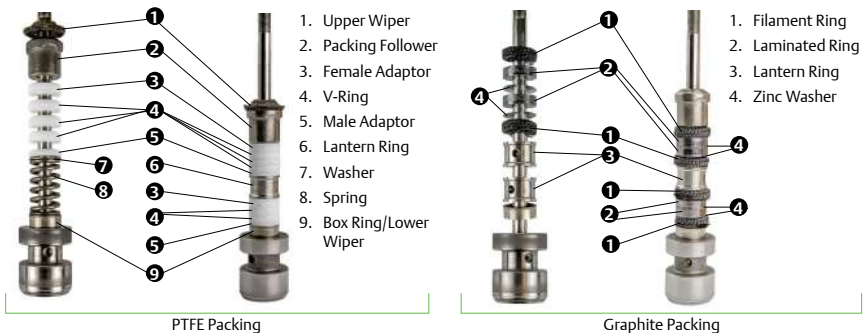

Figure 1.11 Packing

the selection of an actuator for a given control valve will be based on how much force is required to overcome static, stem, and dynamic unbalance with an allowance made for adequate seat load.

**Seat Ring:** A part of the valve body assembly that provides a seating surface for the closure member and can provide part of the flow control orifice.

**Separable Flange:** A flange that fits over a valve body flow connection. It is generally held in place by means of a retaining ring.

**Spring Adjuster:** A fitting, usually threaded on the actuator stem or into the yoke, to adjust the spring compression (see bench set in Control Valve Functions and Characteristics Terminology).

**Spring Seat:** A plate to hold the spring in position and to provide a flat surface for the spring adjuster to contact.

**Static Unbalance:** The net force produced on the valve stem by the process fluid pressure acting on the closure member

and stem with the fluid at rest and with stated pressure conditions.

**Stem Connector:** The device that connects the actuator stem to the valve stem.

**Trim:** The internal components of a valve that modulate the flow of the controlled fluid. In a globe valve body, trim would typically include closure member, seat ring, cage, stem, and stem pin.

**Trim, Soft-Seated:** Valve trim with an elastomeric, plastic, or other readily deformable material used either in the closure component or seat ring to provide tight shutoff with minimal actuator forces.

**Valve Body:** The main pressure boundary of the valve that also provides the pipe connecting ends, the fluid flow passageway, and supports the seating surfaces and the valve closure member. Among the most common valve body constructions are: single-ported valve bodies having one port and one valve plug; double-ported valve bodies having

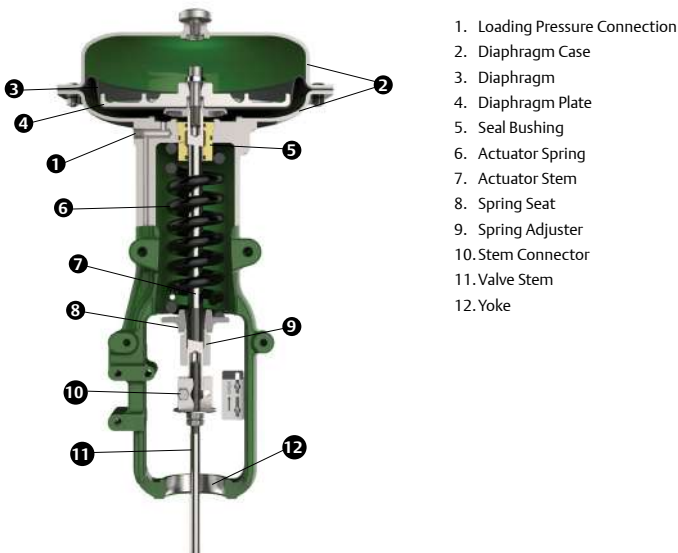

Figure 1.12 Reverse-Acting Actuator

two ports and one valve plug; two-way valve bodies having two flow connections, one inlet and one outlet; three-way valve bodies having three flow connections, two of which can be inlets with one outlet (for converging or mixing flows), or one inlet and two outlets (for diverging or diverting flows). The term “valve body”, or even just “body”, is frequently used in referring to the valve body together with its bonnet assembly and included trim parts. More properly, this group of components should be called the valve body assembly.

**Valve Body Assembly** (*Commonly Valve Body or Valve, more properly Valve Body Assembly*): An assembly of a valve body, bonnet assembly, bottom flange (if used), and trim elements. The trim includes the closure member, which opens, closes, or partially obstructs one or more ports.

**Valve Plug (Plug)**: A term frequently used to reference the valve closure member in a sliding-stem valve.

**Valve Stem**: In a linear motion valve, the part that connects the actuator stem with the closure member.

**Yoke**: The structure that rigidly connects the actuator power unit to the valve. ■

## 1.3 Rotary Control Valve Terminology

The following terminology applies to the physical and operating characteristics of rotary control valves with diaphragm or piston actuators. The closure members (i.e. balls, disks, eccentric plugs, etc.) in rotary designs perform a function comparable to the valve plug in a sliding-stem control valve. That is, as they rotate they vary the size and shape of the flow stream by opening more or less of the seal area to the flowing fluid. Many of the definitions presented are in accordance with ISA S75.05, Control

Valve Terminology, although other popular terms are also included. Terms pertaining to actuators are also appropriate for rotary control valves. Additional explanation is provided for some of the more complex terms. Additional sections in this chapter follow that define specific terminology for general process control, and control valve functions and characteristics.



Figure 1.13 Rotary Control Valve

**Actuator Lever**: Arm attached to rotary valve shaft to convert linear actuator stem motion to rotary force (torque) to position a disk or ball of a rotary valve. The lever normally is positively connected to the rotary by close tolerance splines or other means to minimize play and lost motion.

**Ball, Full**: The flow closure member of rotary control valves using a complete sphere with a cylindrical flow passage through it. The flow passage equals or matches the pipe diameter.

**Ball, Segmented**: The flow closure member of rotary control valves using a partial sphere with a flow passage through it.



Figure 1.14 Segmented Ball

**Ball, V-Notch:** The most common type of segmented ball control valve. The V-notch ball includes a polished or plated partial sphere surface that rotates against the seal ring throughout the travel range. The V-shaped notch in the ball permits wide rangeability and produces an equal-percentage flow characteristic.



Figure 1.15 V-Notch Ball

**Disk, Conventional:** The symmetrical flow closure member used in the most common varieties of butterfly rotary valves. Highly-dynamic torques normally limit conventional disks to 60 degrees maximum rotation in throttling service.

**Disk, Dynamically-Designed:** A butterfly valve disk contoured to reduce dynamic torque at large increments of rotation, thereby making it suitable for throttling service with up to 90 degrees of disk rotation.

**Disk, Eccentric:** Common name for valve design in which the off-centered positioning of the valve shaft/disk connections causes the disk to take a slightly eccentric (cammed) path on

opening. This allows the disk to be swung out of contact with the seal as soon as it is opened, reducing friction and wear.



Figure 1.16 Eccentric Disk Valve

**Flangeless Valve:** Valve style common to rotary control valves. Flangeless valves are held between ANSI/ASME-class flanges by long through-bolts (sometimes also called wafer-style valve bodies).

**Plug, Eccentric:** Style of rotary control valve with an eccentrically-rotating plug which cams into and out of the seat, which reduces friction and wear. This style of valve is well suited for erosive applications.

**Reverse Flow:** Flow from the shaft/hub side over the back of the disk, ball, or plug. Some rotary control valves are capable of handling flow equally well in either direction. Other rotary designs might require modification of actuator linkage to handle reverse flow.

**Rod End Bearing:** The connection often used between actuator stem and actuator lever to facilitate conversion of linear actuator thrust to rotary force (torque) with minimum of lost motion. Use of a standard reciprocating actuator on a rotary valve body commonly requires linkage with two rod end bearings. However, selection of an actuator specifically designed for rotary valve service requires only one such bearing and thereby reduces lost motion.

**Rotary Control Valve:** A valve style in which the flow closure member (full ball,

partial ball, disk or plug) is rotated in the flow stream to control the capacity of the valve. See Figure 1.17.

**Seal Ring:** The portion of a rotary control valve assembly corresponding to the seat ring of a globe valve. Positioning of the disk or ball relative to the seal ring determines the flow area and capacity of the unit at that particular increment of rotational travel.

**Shaft:** The portion of a rotary control valve assembly corresponding to the valve stem of a globe valve. Rotation of the shaft positions the disk or ball in the flow stream and controls flow through the valve.

**Sliding Seal:** The lower cylinder seal in a pneumatic piston-style actuator designed for rotary valve service. This seal permits the actuator stem to move both vertically and laterally without leakage of lower cylinder loading pressure, allowing for a single rod end bearing.

**Standard Flow:** For those rotary control valves having a separate seal ring or flow ring, the flow direction in which fluid enters the valve body through the pipeline adjacent to the seal ring and

exits from the side opposite the seal ring. Sometimes called forward flow or flow into the face of the closure member. See also Reverse Flow.

**Trunnion Mounting:** A style of mounting the disk or ball on the valve shaft or stub shaft with two diametrically opposed bearings. ■

## 1.4 Control Valve Functions and Characteristics Terminology

**Bench Set:** The calibration procedure of an actuator spring so that it can use a pressure range to fully stroke a valve to its rated travel (see Inherent Diaphragm Pressure Range).

**Capacity:** Amount of flow through a valve ( $C_v$  or  $K_v$ ), under stated conditions.

**Clearance Flow:** Flow that occurs below the minimum controllable flow with the closure member not fully seated.

**Diaphragm Pressure Span:** Difference between the high and low values of the diaphragm loading pressure range.

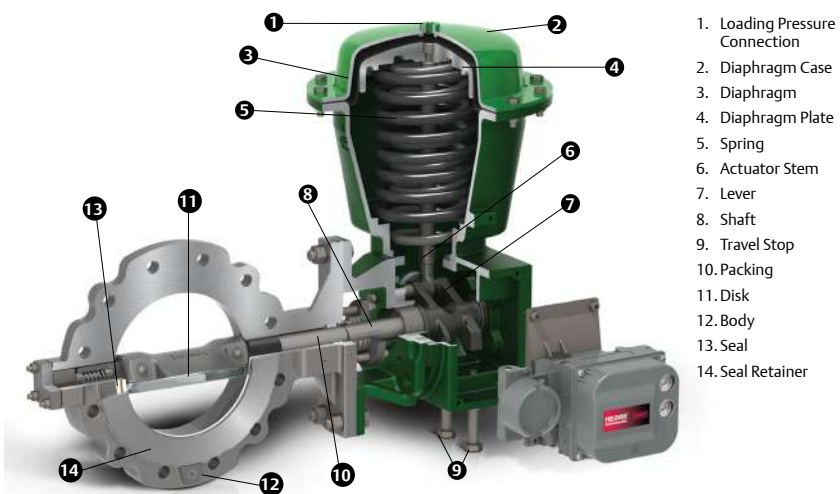

Figure 1.17 Rotary Control Valve



**Double-Acting Actuator:** An actuator in which pneumatic, hydraulic, or electric power is supplied in either direction.

**Dynamic Unbalance:** The net force produced on the valve plug in any stated open position by the fluid process pressure acting upon it.

**Effective Area:** In an actuator, the part of the diaphragm or piston area that produces a stem force. The effective area of a diaphragm might change as it is stroked, usually being a maximum at the start and a minimum at the end of the travel range. Molded diaphragms have less change in effective area than flat sheet diaphragms; thus, molded diaphragms are recommended.

**Fail-Closed:** A condition wherein the valve closure member moves to a closed position when the actuating energy source fails.

**Fail-Open:** A condition wherein the valve closure member moves to an open position when the actuating energy source fails.

**Fail-Safe:** A characteristic of a valve and its actuator, which upon loss of actuating energy supply, will cause a valve closure member to be fully closed, fully open, or remain in the last position, whichever position is defined as necessary to protect the process and equipment. action can involve the use of auxiliary controls connected to the actuator.

**Flow Characteristic:** Relationship between flow through the valve and percent rated travel as the latter is varied from 0 to 100%. This term should always be designated as either inherent flow characteristic or installed flow characteristic (See definitions in Process Control Terminology Section).

**Flow Coefficient ( $C_v$ ):** A constant related to the geometry of a valve, for a given travel, that can be used to establish flow capacity. It is the number of U.S. gallons

per minute of 16°C (60°F) water that will flow through a valve with a one pound per square inch pressure drop.

**High-Recovery Valve:** A valve design that dissipates relatively little flow stream energy due to streamlined internal contours and minimal flow turbulence. Therefore, pressure downstream of the valve vena contracta recovers to a high percentage of its inlet value. Straight-through flow valves, such as rotary ball valves, are typically high-recovery valves.

**Inherent Diaphragm Pressure Range:** The high and low values of pressure applied to the diaphragm to produce rated valve plug travel with atmospheric pressure in the valve body. This range is often referred to as a bench set range because it will be the range over which the valve will stroke when it is set on the work bench.

**Inherent Flow Characteristic:** The relationship between the flow rate and the closure member travel as it is moved from the closed position to rated travel with constant pressure drop across the valve.

**Installed Diaphragm Pressure Range:** The high and low values of pressure applied to the diaphragm to produce rated travel with stated conditions in the valve body. It is because of the forces acting on the closure member that the inherent diaphragm pressure range can differ from the installed diaphragm pressure range.

**Installed Flow Characteristic:** The relationship between the flow rate and the closure member travel as it is moved from the closed position to rated travel as the pressure drop across the valve is influenced by the varying process conditions.

**Low-Recovery Valve:** A valve design that dissipates a considerable amount of flow stream energy due to turbulence



created by the contours of the flow path. Consequently, pressure downstream of the valve vena contracta recovers to a lesser percentage of its inlet value than is the case with a valve having a more streamlined flow path. Although individual designs vary, conventional globe-style valves generally have low pressure recovery capability.

### **Modified Parabolic Flow**

**Characteristic:** An inherent flow characteristic that provides equal-percentage characteristic at low closure member travel and approximately a linear characteristic for upper portions of closure member travel.

**Normally-Closed Valve:** See Fail-Closed.

**Normally-Open Valve:** See Fail-Open.

### **Push-Down-to-Close (PDTC)**

**Construction:** A globe-style valve construction in which the closure member is located between the actuator and the seat ring, such that extension of the actuator stem moves the closure member toward the seat ring, finally closing the valve. The term can also be applied to rotary valve constructions where linear extension of the actuator stem moves the ball or disk toward the closed position. Also called direct-acting.

### **Push-Down-to-Open (PDTO)**

**Construction:** A globe-style valve construction in which the seat ring is located between the actuator and the closure member, so that extension of the actuator stem moves the closure member from the seat ring, opening the valve. The term can also be applied to rotary valve constructions where linear extension of the actuator stem moves the ball or disk toward the open position. Also called reverse-acting.

**Rangeability:** The ratio of the largest flow coefficient ( $C_v$  or  $K_v$ ) to the smallest flow coefficient ( $C_v$  or  $K_v$ ) within which the deviation from the specified flow

characteristic does not exceed the stated limits. A control valve that still does a good job of controlling when flow increases to 100 times the minimum controllable flow has a rangeability of 100 to 1. Rangeability can also be expressed as the ratio of the maximum to minimum controllable flow rates.

**Rated Flow Coefficient ( $C_v$ ):** The flow coefficient ( $C_v$ ) of the valve at rated travel.

**Rated Travel:** The distance of movement of the closure member from the closed position to the rated full-open position. The rated full-open position is the maximum opening recommended by the manufacturers.

**Relative Flow Coefficient ( $C_v$ ):** The ratio of the flow coefficient ( $C_v$ ) at a stated travel to the flow coefficient ( $C_v$ ) at rated travel.

**Seat Leakage:** The quantity of fluid passing through a valve when the valve is in the fully closed position and maximum available seat load is applied with pressure differential and temperature as specified.

**Spring Rate ( $K_s$ ):** The force change per unit change in length of a spring. In diaphragm actuators, the spring rate is usually stated in pounds force per inch compression.

**Vena Contracta:** The portion of a flow stream where fluid velocity is at its maximum and fluid static pressure and the cross-sectional area are at their minimum. In a control valve, the vena contracta normally occurs just downstream of the actual physical restriction. ■

## **1.5 Process Control Terminology**

The following terms and definitions not previously defined are frequently encountered by people associated with

control valves, instrumentation, and accessories. Some of the terms, indicated with an asterisk (\*), are derived from the ISA standard, Process Instrumentation Terminology, ISA 51.1. Other popular terminology used throughout the control valve industry is also included.

**Accessory:** A device mounted to a control valve assembly to complement various functions or produce desired actions, particularly actuation. (i.e. positioners, supply pressure regulators, solenoids, limit switches, etc.).

**Actuator\*:** A pneumatic, hydraulic, or electrically powered device that supplies force and motion to open or close a valve.

**Actuator Assembly:** An actuator, including all the pertinent accessories that make it a complete operating unit.

**ANSI:** Abbreviation for American National Standards Institute.

**API:** Abbreviation for American Petroleum Institute.

**ASME:** Abbreviation for American Society of Mechanical Engineers.

**ASTM:** Used to stand for American Society for Testing and Materials. As the scope of the organization became international, the name was changed to ASTM International. ASTM is no longer an abbreviation.

**Automatic Control System\*:** A control system that operates without human intervention.

**Backlash:** A form of deadband that results from a temporary discontinuity between the input and output of a device when the input of the device changes direction. (i.e. slack, or looseness, of a mechanical connection).

**Bode Diagram\*:** A plot of log amplitude ratio and phase angle values on a log frequency base for a transfer function. It is the most common form of graphically

presenting frequency response data.

**Calibration Curve\*:** A graphical representation of the calibration report. Steady state output of a device plotted as a function of its steady state input. The curve is usually shown as percent output span versus percent input span.

**Calibration Cycle\*:** The application of known values of the measured variable and the recording of corresponding values of output readings, over the range of the instrument, in ascending and descending directions. A calibration curve obtained by varying the input of a device in both increasing and decreasing directions. It is usually shown as percent output span versus percent input span and provides a measurement of hysteresis.

**Capacity\*(Valve):** The amount of flow through a valve ( $C_v$ ) under stated conditions.

**Closed Loop:** The interconnection of process control components such that information regarding the process variable is continuously fed back to a controller set point to provide continuous, automatic corrections to the process variable.

**Closure Member:** A valve trim element (also known as a plug, disk, segmented ball, or full-port ball) used to modulate the flow rate within a control valve.

**Controller:** A device that operates automatically, by use of some established algorithm, to regulate a controlled variable. The controller input receives information about the status of the process variable and then provides an appropriate output signal to the final control element.

**Control Loop:** See Closed Loop or Open Loop.

**Control Range:** The range of valve travel over which a control valve can maintain the installed valve gain between the

normalized values of 0.5 and 2.0.

**Control Valve Assembly:** A device used to modulate fluid flow by varying the size of the flow passage as directed by a signal from a controller.

**Deadband:** A general phenomenon, that can apply to any device, where the range through which an input signal can be varied, upon reversal of direction, without initiating an observable change in output signal. For control valves, the controller output (CO) is the input to the valve assembly and the process variable (PV) is the output, as shown in Figure 1.18. Whenever discussing deadband, it is essential that both the input and output variables are identified, and that any quantifiable tests be conducted under fully-loaded conditions. Deadband is typically expressed as a percent of the input span.

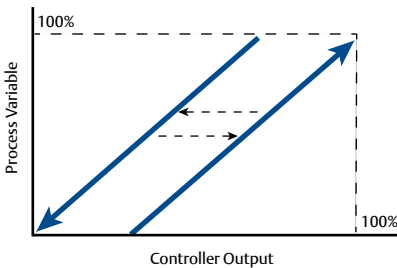

Figure 1.18 Deadband

**Dead Time:** The time interval ( $T_d$ ) in which no response of the system is detected following a small (usually 0.25% - 5%) step input. This time is derived from the moment the step input is initiated to the first detectable response of the system. Dead time can apply to a valve assembly or to the entire process. See T63.

**Enthalpy:** A thermodynamic quantity that is the sum of the internal energy of a body and the product of its volume multiplied by the pressure:  $H = U + pV$ . Also called the heat content.

**Entropy:** The theoretical measure of energy that cannot be transformed into mechanical work in a thermodynamic system.

**Equal-Percentage Characteristic\*:** An inherent flow characteristic that, for equal increments of rated travel, will ideally give equal-percentage changes of the flow coefficient ( $C_v$ ) from the existing  $C_v$ .

**Feedback Signal\*:** The return signal that results from a measurement of the directly controlled variable. For a control valve with a positioner, the return signal is usually a mechanical indication of closure member stem position that is fed back into the positioner.

**FCI:** Abbreviation for Fluid Controls Institute. Provides standards and educational materials to assist purchasers and users in understanding and using fluid control and conditioning equipment.

**Final Control Element:** A device that implements the control strategy determined by the output of a controller. While this final control element can take many forms (dampers, on/off switching devices, etc.) the most common final control element in industry today is the control valve assembly. Control valves modulate flowing fluid (i.e. gas, steam, water, chemical compounds, etc.) to compensate for load disturbances and keep the regulated process variable as close to the desired set point as possible.

**First-Order:** A term referring to the dynamic relationship between the input and output of a device. First-order systems, or devices, have only one energy storage device and the dynamic transient relationship between the input and output is characterized by an exponential behavior.

**Frequency Response Characteristic\*:** The frequency-dependent relation, in both amplitude and phase, between

steady-state sinusoidal inputs and the resulting fundamental sinusoidal outputs. Output amplitude and phase shift are observed as functions of the input test frequency and used to describe the dynamic behavior of the control device.

**Friction:** A force that tends to oppose the relative motion between two surfaces that are in contact with each other. The associated force is a function of the normal force holding these two surfaces together and the characteristic nature of the two surfaces. Friction has two components: static friction and dynamic friction. Static friction (also known as stick/slip, or stiction) is the force that must be overcome before there is any relative motion between the two surfaces. Static friction is also one of the major causes of deadband in a valve assembly. Once relative movement has begun, dynamic friction (also known as running friction, or sliding friction) is the force that must be overcome to maintain the relative motion.

**Gain:** Term used to describe the ratio of the magnitude of an output change of a given system or device to the magnitude of an input change that caused the output change. Gain has two components: static gain and dynamic gain. Static gain (also known as sensitivity) is the gain relationship between the input and output and is an indicator of the ease with which the input can initiate a change in the output when the system or device is in a steady-state condition. Dynamic gain is the gain relationship between the input and output when the system is in a state of movement or flux. Dynamic gain is a function of frequency or rate of change of the input.

**Hardness:** Resistance of metal to plastic deformation, usually by indentation. Resistance of plastics and rubber to penetration of an indenter

point into its surface.

**Hunting\*:** An undesirable oscillation of appreciable magnitude, prolonged after external stimuli disappear. Sometimes called cycling or limit cycle, hunting is evidence of operation at or near the stability limit. In control valve applications, hunting would appear as an oscillation in the loading pressure to the actuator caused by instability in the or the valve positioner.

**Hysteresis\*:** The maximum difference in output value for any single input value during a calibration cycle, excluding errors due to deadband. A retardation of an effect when the forces acting upon a body are changed (as if from viscosity or internal friction).

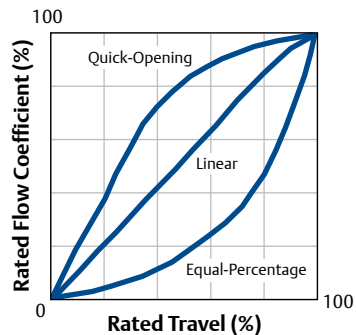

Figure 1.19 Inherent Valve Characteristics

**Inherent Characteristic\*:** The relationship between the flow coefficient and the closure member travel as it is moved from the closed position to rated travel with constant pressure drop across the valve. Typically, these characteristics are plotted on a curve where the horizontal axis is labeled in percent travel and the vertical axis is labeled as percent flow (or  $C_v$ ). Because valve flow is a function of both the valve travel and the pressure drop across the valve, conducting flow characteristic tests at a constant pressure drop provides a systematic way of comparing one valve

characteristic design to another. Typical valve characteristics conducted in this manner are named linear, equal-percentage, and quick opening.

**Inherent Valve Gain:** The magnitude ratio of the change in flow through the valve to the change in valve travel under conditions of constant pressure drop. Inherent valve gain is an inherent function of the valve design. It is equal to the slope of the inherent characteristic curve at any travel point and is a function of valve travel.

**Installed Characteristic\*:** The relationship between the flow rate and the closure member (disk) travel as it is moved from the closed position to rated travel as the pressure drop across the valve is influenced by the varying process conditions.

**Installed Valve Gain:** The magnitude ratio of the change in flow through the valve to the change in valve travel under actual process conditions. Installed valve gain is the valve gain relationship that occurs when the valve is installed in a specific system and the pressure drop is allowed to change naturally according to the dictates of the overall system. The installed valve gain is equal to the slope of the installed characteristic curve, and is a function of valve travel.

**Instrument Pressure:** The output pressure from an automatic controller that is used to operate a control valve.

**I/P:** Shorthand for current-to-pressure (I-to-P). Typically applied to input transducer modules.

**ISA:** Abbreviation for the International Society for Automation.

**Linearity\*:** The closeness to which a curve relating to two variables approximates a straight line. Linearity also means that the same straight line will apply for both upscale and downscale directions. Thus, deadband

as defined above, would typically be considered a non-linearity.

**Linear Characteristic\*:** An inherent flow characteristic that can be represented by a straight line on a rectangular plot of flow coefficient ( $C_v$ ) versus rated travel. Therefore equal increments of travel provide equal increments of flow coefficient,  $C_v$ .

**Loading Pressure:** The pressure employed to position a pneumatic actuator. This is the pressure that actually works on the actuator diaphragm or piston and it can be the instrument pressure if a valve positioner is not used.

**Loop:** See Closed Loop or Open Loop.

**Loop Gain:** The combined gain of all the components in the loop when viewed in series around the loop. Sometimes referred to as open loop gain. It must be clearly specified whether referring to the static loop gain or the dynamic loop gain at some frequency.

**Manual Control:** See Open Loop.

**NACE:** Used to stand for National Association of Corrosion Engineers. As the scope of the organization became international, the name was changed to NACE International. NACE is no longer an abbreviation.

**Open Loop:** The condition where the interconnection of process control components is interrupted such that information from the process variable is no longer fed back to the controller set point so that corrections to the process variable are no longer provided. This is typically accomplished by placing the controller in the manual operating position.

**Operating Medium:** This is the fluid, generally air or gas, used to supply the power for operation of valve positioner or automatic controller.

**Operative Limits\*:** The range of

operating conditions to which a device can be subjected without permanent impairment of operating characteristics.

**OSHA:** Abbreviation for Occupational Safety and Health Administration. (U.S.)

**Packing:** A part of the valve assembly used to seal against leakage around the valve shaft or stem.

**Positioner\*:** A position controller (servomechanism) that is mechanically connected to a moving part of a final control element or its actuator and that automatically adjusts its output to the actuator to maintain a desired position in proportion to the input signal.

**Process:** All the combined elements in the control loop, except the controller. Sometimes refers to the fluid that passes through the loop.

**Process Gain:** The ratio of the change in the controlled process variable to a corresponding change in the output of the controller.

**Process Variability:** A precise statistical measure of how tightly the process is being controlled about the set point. Process variability is defined in percent as typically  $(2s/m)$ , where  $m$  is the set point or mean value of the measured process variable and  $s$  is the standard deviation of the process variable.

**Quick-Opening (QO) Characteristic\*:** An inherent flow characteristic in which a maximum flow coefficient is achieved with minimal closure member travel.

**Range:** The region between the limits within which a quantity is measured, received, or transmitted, expressed by stating the lower and upper range values. For example: 3 to 15 psi; -40 to 100°C (-40 to 212°F).

**Relay:** A device that acts as a power amplifier. It takes an electrical, pneumatic, or mechanical input signal and produces an output of a large

volume flow of air or hydraulic fluid to the actuator. The relay can be an internal component of the positioner or a separate valve accessory.

**Repeatability\*:** The closeness of agreement among a number of consecutive measurements of the output for the same value of the input under the same operating conditions, approaching from the same direction, for full-range traverses. It is usually measured as a non-repeatability and expressed as repeatability in percent of span. It does not include hysteresis.

**Resolution:** The minimum possible change in input required to produce a detectable change in the output when no reversal of the input takes place. Resolution is typically expressed as a percent of the input span.

**Response Time:** Usually measured by a parameter that includes both dead time and time constant. (See T63, Dead Time, and Time Constant.) When applied to the valve, it includes the entire valve assembly.

**Second-Order:** A term that refers to the dynamic relationship between the input and output of a device. A second-order system or device is one that has two energy storage devices that can transfer kinetic and potential energy back and forth between themselves, thus introducing the possibility of oscillatory behavior and overshoot.

**Sensitivity\*:** The ratio of the change in output magnitude to the change of the input that causes it after the steady-state has been reached.

**Sensor:** A device that senses the value of the process variable and provides a corresponding output signal to a transmitter. The sensor can be an integral part of the transmitter, or it may be a separate component.

**Set Point:** A reference value

representing the desired value of the process variable being controlled.

**Shaft Wind-Up:** A phenomenon where one end of a valve shaft turns and the other does not. This typically occurs in rotary-style valves where the actuator is connected to the valve closure member by a relatively long shaft. While seal friction in the valve holds one end of the shaft in place, rotation of the shaft at the actuator end is absorbed by twisting of the shaft until the actuator input transmits enough force to overcome the friction.

**Signal\*:** A physical variable, one or more parameters of which carry information about another variable the signal represents.

**Signal Amplitude Sequencing (Split Ranging)\*:** Action in which two or more signals are generated or two or more final controlling elements are actuated by an input signal, each one responding consecutively, with or without overlap, to the magnitude of that input signal.

**Sizing (Valve):** A systematic procedure designed to ensure the correct valve capacity for each condition of a set of specified process conditions.

**Span\*:** The algebraic difference between the upper and lower range values. For example: If range = 0 to 66°C (150°F), then span = 66°C (150°F); if range = 3 to 15 psig, then span = 12 psig.

**Stiction (Static Friction):** the force required to cause one body in contact with another to begin to move. Also see Friction.

**Supply Pressure\*:** The pressure at the supply port of a device. Common values of control valve supply pressure are 20 psig for a 3 to 15 psig range and 35 psig for a 6 to 30 psig range.

**T63:** A measure of device response. It is measured by applying a small (usually 1-5%) step input to the system. T63 is

measured from the time the step input is initiated to the time when the system output reaches 63% of the final steady-state value. It is the combined total of the system dead time ( $T_d$ ) and the system time constant ( $t$ ). See Dead Time and Time Constant.

**Time Constant:** A time parameter that normally applies to a first-order element. It is the time interval measured from the first detectable response of the system to a small (usually 0.25% - 5%) step input until the system output reaches 63% of its final steady-state value. (See T63.) When applied to an open-loop process, the time constant is usually designated as "T" (Tau). When applied to a closed-loop system, the time constant is usually designated as  $\lambda$  (Lambda).

**Transmitter:** A device that senses the value of the process variable and transmits a corresponding output signal to the controller for comparison with the set point.

**Travel\*:** The movement of the closure member from the closed position to an intermediate or rated full-open position.

**Travel Indicator:** A pointer and scale used to externally show the position of the closure member typically with units of opening percent of travel or degrees of rotation.

**Trim\*:** The internal components of a valve that modulate the flow of the controlled fluid.

**Valve:** See Control Valve Assembly.

**Volume Booster:** A stand-alone relay is often referred to as a volume booster or simply booster because it boosts, or amplifies, the volume of air supplied to the actuator. See Relay.

**Zero Error\*:** Error of a device operating under specified conditions of use when the input is at the lower range value. It is usually expressed as percent of ideal span. ■



# Chapter 2

## Control Valve Performance





In today's dynamic business environment, manufacturers are under extreme economic pressures. Market globalization is resulting in intense pressures to reduce manufacturing costs to compete with lower wages and raw material costs of emerging countries. Competition exists between international companies to provide the highest quality products and to maximize plant throughputs with fewer resources; all while meeting ever-changing customer needs. These marketing challenges must be met, although fully complying with public and regulatory policies.

## 2.1 Process Variability

To deliver acceptable returns to their shareholders, international industry leaders are realizing they must reduce raw material and scrap costs while increasing productivity. Reducing process variability in the manufacturing processes through the application of process control technology is recognized as an effective method to improve financial returns and meet global competitive pressures.

The basic objective of a company is to make a profit through the production of a quality product. A quality product conforms to a set of specifications. Any deviation from the established specification means lost profit due to excessive material use, reprocessing costs, or wasted product. Thus, a large financial impact is obtained through improving process control. Reducing process variability through better process control allows optimization of the process and the production of products right the first time.

The non-uniformity inherent in the raw materials and processes of production are common causes of variation that produce a variation of the process

variable both above and below the set point. A process that is in control, with only the common causes of variation present, typically follows a bell-shaped normal distribution.

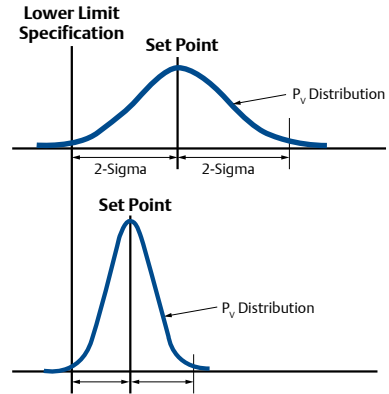

Figure 2.1 Process Variability

A statistically derived band of values on this distribution, called the  $\pm 2$  sigma band, describes the spread of process variable deviations from the set point. This band is the variability of the process. It is a measure of how tightly the process is being controlled. Process variability is a precise measure of tightness of control and is expressed as a percentage of the set point.

If a product must meet a certain lower limit specification, for example, the set point needs to be established at a 2 sigma value above this lower limit. Doing so will ensure that all the product produced at values to the right of the lower limit will meet the quality specification.

The problem, however, is that money and resources are being wasted by making a large percentage of the product to a level much greater than required by the specification (see upper distribution in Figure 2.1).

The most desirable solution is to reduce the spread of the deviation about the set



Figure 2.2 Performance Test Loop

point by using a control valve that can produce a smaller sigma (see the lower distribution in Figure 2.1).

Reducing process variability is a key to achieving business goals. Most companies realize this, and it is not uncommon for them to spend hundreds of thousands of dollars on instrumentation to address the problem of process variability reduction.

Unfortunately, the control valve is often overlooked in this effort because its impact on dynamic performance is not realized. Extensive studies of control loops indicate as many as 80% of the loops did not do an adequate job of reducing process variability. Furthermore, the control valve was found to be a major contributor to this problem for a variety of reasons.

To verify performance, manufacturers must test their products under dynamic

process conditions. These are typically performed in a flow lab in actual closed-loop control (Figure 2.2). Evaluating control valve assemblies under closed-loop conditions provides the only true measure of variability performance. Closed-loop performance data proves significant reductions in process variability can be achieved by choosing the right control valve for the application.

The ability of control valves to reduce process variability depends upon many factors. More than one isolated parameter must be considered. Research within the industry has found the particular design features of the final control element, including the valve, actuator, and positioner, are very important in achieving good process control under dynamic conditions. Most importantly, the control valve assembly must be optimized or developed as a unit. Valve components not designed as

a complete assembly typically do not yield the best dynamic performance. Some of the most important design considerations include:

- Deadband
- Actuator/positioner design
- Valve response time
- Valve type and characterization
- Valve sizing

Each of these design features will be considered in this chapter to provide insight into what constitutes a superior valve design.

### 2.1.1 Deadband

Deadband is a major contributor to excess process variability. Control valve assemblies can be a primary source of deadband in an instrumentation loop due to a variety of causes such as friction, backlash, shaft wind-up, relay or spool valve dead zone, etc.

Deadband is a general phenomenon where a range or band of controller output (CO) values fail to produce a change in the measured process variable (PV) when the input signal reverses direction. When a load disturbance occurs, the process variable (PV) deviates from the set point. This deviation initiates a corrective action through the controller and back through the process. However, an initial change in controller output can produce no corresponding corrective change in the process variable. Only when the controller output has changed enough to progress through the deadband does a corresponding change in the process variable occur.

Any time the controller output reverses direction, the controller signal must pass through the deadband before any corrective change in the process variable will occur. The presence of deadband in the process ensures the process variable

deviation from the set point will have to increase until it is big enough to get through the deadband. Only then can a corrective action occur.

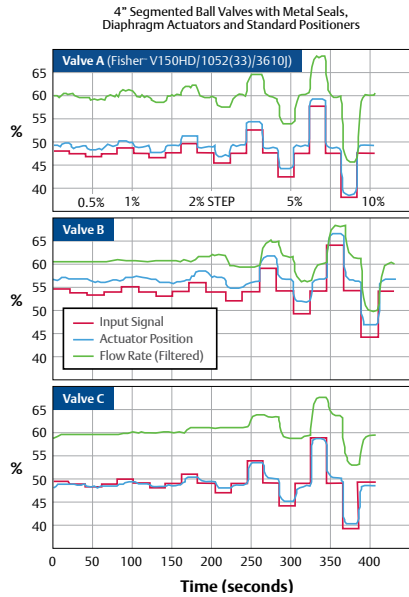

Figure 2.3 Effect of Deadband on Valve Performance

#### 2.1.1.1 Causes of Deadband

Deadband has many causes, but friction and backlash in the control valve, along with shaft wind-up in rotary valves, and relay dead zone are some of the more common forms. Because most control actions for regulatory control consist of small changes (1% or less), a control valve with excessive deadband might not even respond to many of these small changes. A well-engineered valve should respond to signals of 1% or less to provide effective reduction in process variability. However, it is not uncommon for some valves to exhibit deadband as great as 5% or more. In a recent plant audit, 30% of the valves had deadbands in excess of 4%. Over 65% of the loops audited had deadbands greater than 2%.

### 2.1.1.2 Effects of Deadband

Figure 2.3 shows just how dramatic the combined effects of deadband can be. This diagram represents an open-loop test of three different control valves under normal process conditions. The valves are subjected to a series of step inputs which range from 0.5% to 10%. Step tests under flowing conditions are essential because they allow the performance of the entire valve assembly to be evaluated, rather than just the valve actuator assembly as would be the case under most bench test conditions.

### 2.1.1.3 Performance Tests

Some performance tests on a valve assembly compare only the actuator stem travel versus the input signal. This is misleading because it ignores the performance of the valve itself.

It is critical to measure dynamic performance of a valve under flowing conditions so the change in process variable can be compared to the change in valve assembly input signal. It matters little if only the valve stem changes in response to a change in valve input because if there is no corresponding change in the controlled variable, there will be no correction to the process variable.

In all three valve tests (Figure 2.3), the actuator stem motion changes fairly faithfully in response to the input signal changes. On the other hand, there is a dramatic difference in each of the valve's ability to change the flow in response to an input signal change.

For Valve A, the process variable (flow rate) responds well to input signals as low as 0.5. Valve B requires input signal changes as great as 5% before it begins responding faithfully to each of the input signal steps. Valve C is considerably worse, requiring signal changes as great

as 10% before it begins to respond faithfully to each of the input signal steps. The ability of either Valve B or C to improve process variability is very poor.

### 2.1.1.4 Friction

Friction is a major cause of deadband in control valves. Rotary valves are often very susceptible to friction caused by the high seat loads required to obtain shutoff with some seal designs. Because of the high seal friction and poor drive train stiffness, the valve shaft winds up and does not translate motion to the control element. As a result, an improperly designed rotary valve can exhibit significant deadband that clearly has a detrimental effect on process variability.

Manufacturers usually lubricate rotary valve seals during manufacture, but after only a few hundred cycles this lubrication wears off. In addition, pressure-induced loads also cause seal wear. As a result, the valve friction can increase by 400% or more for some valve designs. This illustrates the misleading performance conclusions that can result from evaluating products using bench-type data before the torque has stabilized. Valves B and C (Figure 2.3) show the devastating effect these higher friction torque factors can have on a valve's performance.

Packing friction is the primary source of friction in sliding-stem valves. In these types of valves, the measured friction can vary significantly between valve styles and packing arrangements.

Actuator style also has a profound impact on control valve assembly friction. Generally, spring-and-diaphragm actuators contribute less friction to the control valve assembly than piston actuators. An additional advantage of spring-and-diaphragm actuators is that their frictional characteristics are more uniform with age. Piston actuator friction

probably will increase significantly with use as guide surfaces and as the O-rings wear, lubrication fails, and the elastomer degrades. Thus, to ensure continued good performance, maintenance is required more often for piston actuators than for spring-and-diaphragm actuators. If that maintenance is not performed, process variability can suffer dramatically without the operator's knowledge.

Backlash results in a discontinuity of motion when the device changes direction. Backlash commonly occurs in gear drives of various configurations. Rack-and-pinion actuators are particularly prone to deadband due to backlash. Some valve shaft connections also exhibit deadband effects. Spline connections generally have much less deadband than keyed shafts or double-D designs.

While friction can be reduced significantly through good valve design, it is a difficult phenomenon to eliminate entirely. A well-engineered control valve should be able to virtually eliminate deadband due to backlash and shaft wind-up.

For best performance in reducing process variability, the total deadband for the entire valve assembly should be 1% or less. Ideally, it should be as low as 0.25%.

### **2.1.2 Actuator and Positioner Design**

Actuator and positioner design must be considered together. The combination of these two pieces of equipment greatly affects the static performance (deadband), as well as the dynamic response of the control valve assembly and the overall air consumption of the valve instrumentation.

Positioners are used with the majority of control valve applications specified today. Positioners allow for precise valve assembly response, as well as online

diagnostics when used with a conventional digital control system. With the increasing emphasis upon economic performance of process control, positioners should be considered for every valve application where process optimization is important.

A positioner can be thought of as a high proportional gain device. When combined with an actuator and valve, the assembly will ideally behave like a first order or underdamped second order system, depending on use and intended performance. A digital valve controller has additional tuning parameters, such as derivative gain, which largely exist to remove undesirable characteristics and further tune the assembly to the desired performance. Many positioners also include an integral capability to remove any offsets between valve set point and position. Under most process control situations, this feature can be turned off to avoid the possibility of forming slow process oscillations, as the offset between valve position and set point is typically handled by the process controller.

Once a change in the set point has been detected by the positioner, the positioner must be capable of supplying a large volume of air to the actuator, making the assembly move in a timely and controlled action. This ability comes from the high-gain positioner and is a function of integrated pneumatic booster within the positioner. This pneumatic booster is typically comprised of a relay or spool valve.

Typical high-performance, two-stage positioners use pneumatic relays. Relays are preferred because they can provide high gain that gives excellent dynamic performance with low steady-state air consumption. In addition, they are less subject to fluid contamination. In addition, some large or high-friction actuators may use additional external boosters to meet specifications, such as

stroking speed.

Positioner designs are continuing to improve by decreasing air consumption and advancing the diagnostic capabilities accessible to users. In addition, features have been added to support advancing industry safety requirements such as safety instrumented systems (SIS) and optimized digital valves.

### **2.1.3 Valve Response Time**

For optimum control of many processes, it is important that the valve reach a specific position quickly. A quick response to small signal changes (1% or less) is one of the most important factors in providing optimum process control. In automatic, regulatory control, the bulk of the signal changes received from the controller are for small changes in position. If a control valve assembly can quickly respond to these small changes, process variability will be improved.

Valve response time is measured by a parameter called T63. T63 is the time measured from initiation of the input signal change to when the output reaches 63% of the corresponding change. It includes both the valve assembly dead time, which is a static time, and the dynamic time of the valve assembly. The dynamic time is a measure of how long the actuator takes to get to the 63% point once it starts moving.

#### **2.1.3.1 Dead Time**

Deadband, whether it comes from friction in the valve body and actuator or from the positioner, can significantly affect the dead time of the valve assembly. It is important to keep the dead time as small as possible, as this can be a limiting factor for process stability. Generally, dead time should be no more than one-third of the overall valve response time. However, the relative relationship between the dead

time and the process time constant is critical. If the valve assembly is in a fast loop where the process time constant approaches the dead time, the dead time can dramatically affect loop performance. On these fast loops, it is critical to select control equipment with dead time as small as possible.

Also, from a loop tuning point of view, it is important that the dead time be relatively consistent in both stroking directions of the valve. Some valve assembly designs can have dead times that are three to five times longer in one stroking direction than the other. This type of behavior is typically induced by the asymmetric behavior of the positioner design, and it can severely limit the ability to tune the loop for best overall performance.

#### **2.1.3.2 Dynamic Time**

Once the dead time has passed and the valve begins to respond, the remainder of the valve response time comes from the dynamic time of the valve assembly. This dynamic time will be determined primarily by the dynamic characteristics of the positioner and actuator combination. These two components must be carefully matched to minimize the total valve response time. In a pneumatic valve assembly, for example, the positioner must have a gain to minimize the dynamic time of the valve assembly. This gain comes mainly from the power amplifier stage in the positioner. In other words, the faster the positioner relay or spool valve can supply a large volume of air to the actuator, the faster the valve response time will be. However, this high-gain power amplifier will have little effect on the dead time unless it has some intentional deadband designed into it to reduce static air consumption. Of course, the design of the actuator significantly affects the dynamic time. For example, the greater the volume of the actuator air chamber to be filled, the slower the valve response time.

Valve Response Time			
	Step Size	T(d) Seconds	T63 Seconds
ENTECH SPEC. 4" VALVE SIZE	%	s0.2	s0.6
Valve A (Fisher V150HD/1052(33)/3610J)			
Valve Action: Opening	2	0.25	0.34
Valve Action: Closing	-2	0.50	0.74
Valve Action: Opening	5	0.16	0.26
Valve Action: Closing	-5	0.22	0.42
Valve Action: Opening	10	0.19	0.33
Valve Action: Closing	-10	0.23	0.46
Valve B			
Valve Action: Opening	2	5.61	7.74
Valve Action: Closing	-2	0.46	1.67
Valve Action: Opening	5	1.14	2.31
Valve Action: Closing	-5	1.04	2
Valve Action: Opening	10	0.42	1.14
Valve Action: Closing	-10	0.41	1.14
Valve C			
Valve Action: Opening	2	4.4	5.49
Valve Action: Closing	-2	NR	NR
Valve Action: Opening	5	5.58	7.06
Valve Action: Closing	-5	2.16	3.9
Valve Action: Opening	10	0.69	1.63
Valve Action: Closing	-10	0.53	1.25
NR = No Response			

Figure 2.4 Valve Response Time Summary

### 2.3.1.3 Solutions

At first, it might appear that the solution would be to minimize the actuator volume and maximize the positioner dynamic power gain, but it is really not that easy. This can be a dangerous combination of factors from a stability point of view. Recognizing that the positioner/actuator combination is its own feedback loop, it is possible to make the positioner/actuator loop gain too high for the actuator design being

used, causing the valve assembly to go into an unstable oscillation. In addition, reducing the actuator volume has an adverse affect on the thrust-to-friction ratio, which increases the valve assembly deadband, resulting in increased dead time.

If the overall thrust-to-friction ratio is not adequate for a given application, one option is to increase the thrust capability of the actuator by using the next size actuator or by increasing the

pressure to the actuator. This higher-to-friction ratio reduces deadband, which should help to reduce the dead time of the assembly. However, both of these alternatives mean that a greater volume of air needs to be supplied to the actuator. The trade off is a possible detrimental effect on the valve response time through increased dynamic time.

One way to reduce the actuator air chamber volume is to use a piston actuator rather than a spring-and-diaphragm actuator, but this is not a panacea. Piston actuators usually have higher thrust capability than spring-and-diaphragm actuators, but they also have higher friction, which can contribute to problems with valve response time. To obtain the required thrust with a piston actuator, it is usually necessary to use a higher air pressure than with a diaphragm actuator, because the piston typically has a smaller area. This means that a larger volume of air needs to be supplied with its attendant ill effects on the dynamic time. In addition, piston actuators, with their greater number of guide surfaces, tend to have higher friction due to inherent difficulties in alignment, as well as friction from the O-ring. These friction problems also tend to increase over time. Regardless of how good the O-rings are initially, these elastomeric materials will degrade with time due to wear and other environmental conditions. Likewise, wear on the guide surfaces will increase the friction, and depletion of the lubrication will occur. These friction problems result in a greater piston actuator deadband, which will increase the valve response time through increased dead time.

### **2.3.1.4 Supply Pressure**

Instrument supply pressure can also have a significant impact on dynamic performance of the valve assembly. For

example, it can dramatically affect the positioner gain, as well as overall air consumption.

Fixed-gain positioners have generally been optimized for a particular supply pressure. This gain, however, can vary by a factor of two or more over a small range of supply pressures. For example, a positioner that has been optimized for a supply pressure of 20 psig might find its gain cut in half when the supply pressure is boosted to 35 psig.

Supply pressure also affects the volume of air delivered to the actuator, which determines speed. It is also directly linked to air consumption. Again, high-gain spool valve positioners can consume up to five times the amount of air required for more efficient high-performance, two-stage positioners that use relays for the power amplification stage.

### **2.3.1.5 Minimizing Dead Time**

To minimize the valve assembly dead time, minimize the deadband of the valve assembly, whether it comes from friction in the valve seal design, packing friction, shaft wind-up, actuator, or positioner design. As indicated, friction is a major cause of deadband in control valves. On rotary valve styles, shaft wind-up can also contribute significantly to deadband. Actuator style also has a profound impact on control valve assembly friction. Generally, spring-and-diaphragm actuators contribute less friction to the control valve assembly than piston actuators over an extended time. As mentioned, this is caused by the increasing friction from the piston O-ring, misalignment problems, and failed lubrication.

Having a positioner design with high gain can make a significant difference in reducing deadband. This can also make a significant improvement in the valve assembly resolution. Valve assemblies



with deadband and resolution of 1% or less are no longer adequate for many process variability reduction needs. Many processes require the valve assembly to have deadband and resolution as low as 0.25%, especially where the valve assembly is installed in a fast process loop.

### 2.3.1.6 Valve Response Time

One of the surprising things to come out of many industry studies on valve response time has been the change in thinking about spring-and-diaphragm actuators versus piston actuators. It has long been a misconception in the process industry that piston actuators are faster than spring-and-diaphragm actuators. Research has shown this to be untrue for small signal changes.

This mistaken belief arose from many years of experience with testing valves for stroking time. A stroking time test is normally conducted by subjecting the valve assembly to a 100% step change in the input signal and measuring the time it takes the valve assembly to complete its full stroke in either direction.

Although piston-actuated valves usually do have faster stroking times than most spring-and-diaphragm actuated valves, this test does not indicate valve performance in a typical process control situation where in normal process control applications, the valve is rarely required to stroke through its full operating range. Typically, the valve is only required to respond within a range of 0.25% to 2% change in valve position. Extensive testing of valves has shown that spring-and-diaphragm valve assemblies consistently outperform piston actuated valves on small signal changes, which are more representative of regulatory process control applications. Higher friction in the piston actuator is one factor that plays a role in making them less responsive to small signals than

spring-and-diaphragm actuators.

Selecting the proper valve, actuator, and positioner combination is not easy. It is not simply a matter of finding a combination that is physically compatible. Good engineering judgment must go into the practice of valve assembly sizing and selection to achieve the best dynamic performance from the loop.

Figure 2.4 shows the dramatic differences in dead time and overall T63 response time caused by differences in valve assembly design.

### 2.1.4 Valve Type and Characterization

The style of valve used and the sizing of the valve can have a large impact on the performance of the control valve assembly in the system. While a valve must be of sufficient size to pass the required flow under all possible contingencies, a valve that is too large for the application is a detriment to process optimization.

Flow capacity of the valve is also related to the style of valve through the inherent characteristic of the valve. The inherent characteristic is the relationship between the valve flow capacity and the valve travel when the differential pressure drop across the valve is held constant.

Typically, these characteristics are plotted on a curve where the horizontal axis is labeled in percent travel although the vertical axis is labeled as percent flow (or  $C_v$ ). Since valve flow is a function of both the valve travel and the pressure drop across the valve, it is traditional to conduct inherent valve characteristic tests at a constant pressure drop. This is not a normal situation in practice, but it provides a systematic way of comparing one valve characteristic design to another.

Under the specific conditions of constant pressure drop, the valve flow becomes only a function of the valve travel and the inherent design of the valve trim. These characteristics are called the inherent flow characteristic of the valve. Typical valve characteristics conducted in this manner are named linear, equal-percentage, and quick-opening.

The ratio of the incremental change in valve flow (output) to the corresponding increment of valve travel (input) which caused the flow change is defined as the valve gain.

$$\text{Inherent Valve Gain} = (\text{Change in Flow}) / (\text{Change in Travel}) = \text{Slope of the Inherent Characteristic Curve}$$

The linear characteristic has a constant inherent valve gain throughout its range, and the quick-opening characteristic has an inherent valve gain that is the greatest at the lower end of the travel range. The greatest inherent valve gain for the equal-percentage valve is at the largest valve opening.

Inherent valve characteristic is an inherent function of the valve flow passage geometry and does not change as long as the pressure drop is held constant. Many valve designs, particularly rotary ball valves, butterfly valves, and eccentric plug valves, have inherent characteristics, which cannot be easily changed. However, most globe valves have a selection of valve cages or plugs that can be interchanged to modify the inherent flow characteristic.

Knowledge of the inherent valve characteristic is useful, but the more important characteristic for purposes of process optimization is the installed flow characteristic of the entire process, including the valve and all other equipment in the loop. The installed flow characteristic is defined as the relationship between the flow through the valve and the valve assembly input when the valve is installed in a specific system, and the pressure drop across the valve is allowed to change naturally, rather than being held constant. An illustration of such an installed flow characteristic is shown in the upper

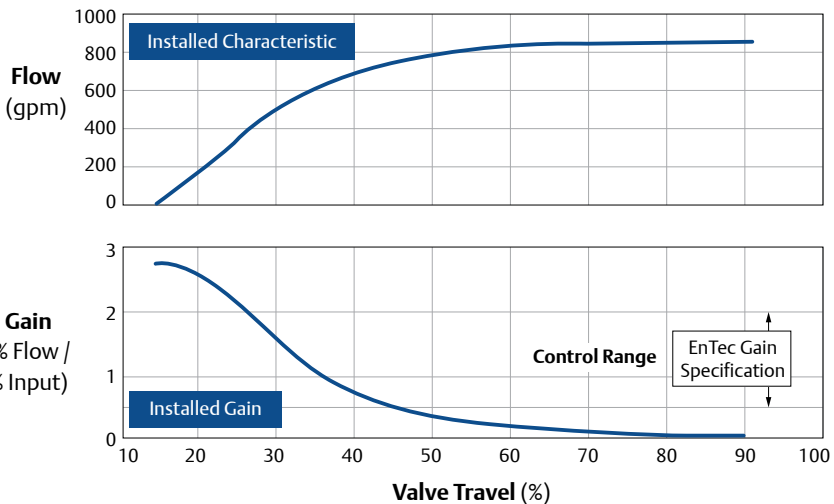

Figure 2.5 Installed Flow Characteristic and Gain

curve of Figure 2.5. The flow in this figure is related to the more familiar valve travel rather than valve assembly input.

### 2.1.4.1 Installed Gain

Installed gain, shown in the lower curve of Figure 2.5, is a plot of the slope of the upper curve at each point. Installed flow characteristic curves can be obtained under laboratory conditions by placing the entire loop in operation at some nominal set point and with no load disturbances. The loop is placed in manual operation, and the flow is then measured and recorded as the input to the control valve assembly is manually driven through its full travel range. A plot of the results is the installed flow characteristic curve shown in the upper part of Figure 2.5. The slope of this flow curve is then evaluated at each point on the curve and plotted as the installed gain as shown in the lower part of Figure 2.5.

Field measurements of the installed process gain can also be made at a single operating point using open-loop step tests (Figure 2.3). The installed process gain at any operating condition is simply the ratio of the percent change in output (flow) to the percent change in valve assembly input signal.

The reason for characterizing inherent valve gain through various valve trim designs is to provide compensation for other gain changes in the control loop. The end goal is to maintain a loop gain, which is reasonably uniform over the entire operating range, to maintain a relatively linear installed flow characteristic for the process. Because of the way it is measured, the installed flow characteristic and installed gain represented in Figure 2.5 are really the installed gain and flow characteristic for the entire process.

Typically, the gain of the unit being

controlled changes with flow. For example, the gain of a pressure vessel tends to decrease with throughput. In this case, the process control engineer would then likely want to use an equal-percentage valve that has an increasing gain with flow. Ideally, these two inverse relationships should balance out to provide a more linear installed flow characteristic for the entire process.

### 2.1.4.2 Loop Gain

Theoretically, a loop has been tuned for optimum performance at some set point flow condition. As the flow varies about that set point, it is desirable to keep the loop gain as constant as possible to maintain optimum performance. If the loop gain change, due to the inherent valve characteristic, does not exactly compensate for the changing gain of the unit being controlled, then there will be a variation in the loop gain due to variation in the installed process gain. As a result, process optimization becomes more difficult. There is also a danger that the loop gain might change enough to cause instability, limit cycling, or other dynamic difficulties.

Loop gain should not vary more than 4:1; otherwise, the dynamic performance of the loop suffers unacceptably. There is nothing magic about this specific ratio; it is simply one which many control practitioners agree produces an acceptable range of gain margins in most process control loops.

This guideline forms the basis for the following EnTech gain limit specification (*from Control Valve Dynamic Specification, Version 3.0, November 1998, EnTech Control Inc., Toronto, Ontario, Canada*):

Loop Process Gain =  $1.0 (\% \text{ of Transmitter Span}) / (\% \text{ Controller Output})$

Nominal Range: 0.5-2.0  
(Note 4-to-1 Ratio)

This definition of the loop process includes all the devices in the loop configuration except the controller. In other words, the product of the gains of such devices as the control valve assembly, the heat exchanger, pressure vessel, or other system being controlled, the pump, the transmitter, etc. is the process gain. Because the valve is part of the loop process as defined here, it is important to select a valve style and size that will produce an installed flow characteristic that is sufficiently linear to stay within the specified gain limits over the operating range of the system. If too much gain variation occurs in the control valve itself, it leaves less flexibility in adjusting the controller. It is good practice to keep as much of the loop gain in the controller as possible.

Although the 4:1 ratio of gain change in the loop is widely accepted, not everyone agrees with the 0.5 to 2.0 gain limits. Some industry experts have made a case for using loop process gain limits from 0.2 to 0.8, which is still 4:1. The potential danger inherent in using this reduced gain range is that the low end of

the gain range could result in large valve swings during normal operation. It is good operating practice to keep valve swings below about 5%. However, there is also a danger in letting the gain get too large. The loop can become oscillatory or even unstable if the loop gain gets too high at some point in the travel. To ensure good dynamic performance and loop stability over a wide range of operating conditions, industry experts recommend that loop equipment be engineered so the process gain remains within the range of 0.5 to 2.0.

### 2.1.4.3 Process Optimization

Process optimization requires a valve style and size be chosen that will keep the process gain within the selected gain limit range over the widest possible set of operating conditions. Because minimizing process variability is so dependent on maintaining a uniform installed gain, the range over which a valve can operate within the acceptable gain specification limits is known as the control range of the valve.

The control range of a valve varies

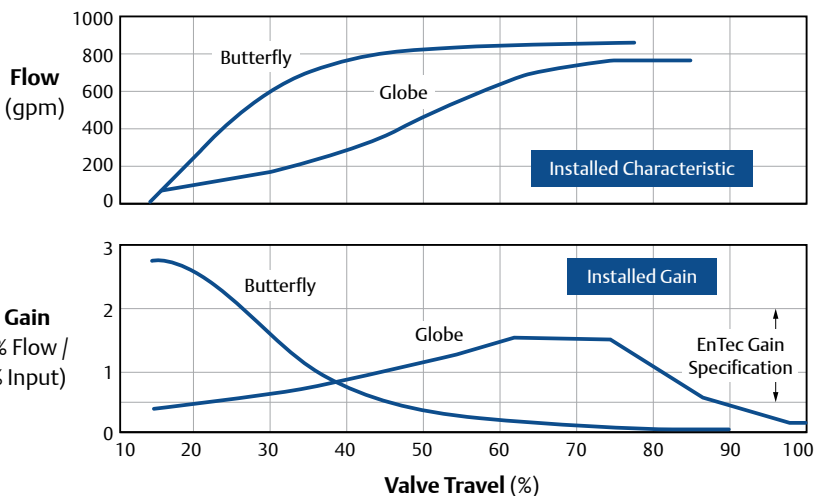

Figure 2.6 Effect of Valve Style on Control Range

dramatically with valve style. Figure 2.6 shows a line-size butterfly valve compared to a line-size globe valve. The globe valve has a much wider control range than the butterfly valve. Other valve styles, such as V-notch ball valves and eccentric plug valves generally fall somewhere between these two ranges.

Because butterfly valves typically have the narrowest control range, they are generally best suited for fixed-load applications. In addition, they must be carefully sized for optimal performance at fixed loads.

If the inherent characteristic of a valve could be selected to exactly compensate for the system gain change with flow, one would expect the installed process gain (lower curve) to be essentially a straight line at a value of 1.0.

Unfortunately, such a precise gain match is seldom possible due to the logistical limitations of providing an infinite variety of inherent valve trim characteristics. In addition, some valve styles, such as butterfly and ball valves, do not offer trim alternatives that allow easy change of the inherent valve characteristic.

This condition can be alleviated by use of non-linear scaling between valve set point and position. This technique recalibrates the valve input signal by taking the linear controller signal and using a pre-programmed table of values to produce the valve input required to achieve the desired valve characteristic. This technique is sometimes referred to as forward path or set point characterization.

This characterization occurs outside the positioner feedback loop, and avoids changing the positioner loop gain. This method also has its dynamic limitations. For example, there can be places in a valve range where a 1.0% process signal change might be narrowed through this

characterization process to only a 0.1% signal change to the valve (that is, in the flat regions of the characterizing curve). Many control valves are unable to respond to signal changes this small.

The best process performance occurs when the required flow characteristic is obtained through changes in the valve trim rather than through use of non-linear characterization. Proper selection of a control valve designed to produce a reasonably linear installed flow characteristic over the operating range of the system is a critical step in ensuring optimum process performance.

### 2.1.5 Valve Sizing

Oversizing of valves sometimes occurs when trying to optimize process performance through a reduction of process variability. This results from using line-size valves, especially with high-capacity rotary valves, as well as the conservative addition of multiple safety factors at different stages in the process design.

Oversizing the valve hurts process variability in two ways. First, the oversized valve puts too much gain in the valve, leaving less flexibility in adjusting the controller. Best performance results when most loop gain comes from the controller.

Notice in the gain curve of Figure 2.5, the process gain gets quite high in the region below about 25% valve travel. If the valve is oversized, making it more likely to operate in or near this region, this high gain can likely mean that the controller gain will need to be reduced to avoid instability problems with the loop. This, of course, will mean a penalty of increased process variability.

The second way oversized valves hurt process variability is that an oversized valve is likely to operate more frequently at lower valve openings where seal

friction can be greater, particularly in rotary valves. Because an oversized valve produces a disproportionately large flow change for a given increment of valve travel, this phenomenon can greatly exaggerate the process variability associated with deadband due to friction.

Regardless of its actual inherent valve characteristic, a severely oversized valve tends to act more like a quick-opening valve, which results in high installed process gain in the lower lift regions (Figure 2.5). In addition, when the valve is oversized, the valve tends to reach system capacity at relatively low travel, making the flow curve flatten out at higher valve travels (Figure 2.5). For valve travels above about 50 degrees, this valve has become totally ineffective for control purposes because the process gain is approaching zero and the valve must undergo wide changes in travel with very little resulting changes in flow. Consequently, there is little hope of achieving acceptable process variability in this region.

The valve shown in Figure 2.5 is totally misapplied in this application because it has such a narrow control range (approximately 25 degrees to 45 degrees). This situation came about because a line-sized butterfly valve was chosen, primarily due to its low cost, and no consideration was given to the lost profit that results from sacrificing process variability through poor dynamic performance of the control valve.

Unfortunately, this situation is often repeated. Process control studies show that, for some industries, the majority of valves currently in process control loops are oversized for the application. While it might seem counterintuitive, it often makes economic sense to select a control valve for present conditions and then replace the valve when conditions change.

When selecting a valve, it is important to

consider the valve style, inherent characteristic, and valve size that will provide the broadest possible control range for the application.

Refer to Chapter 5 for more sizing information. ■

## 2.2 Economic Results

Consideration of the factors discussed in this chapter can have a dramatic impact on the economic results of an operating plant. More and more control valve users focus on dynamic performance parameters such as deadband, response times, and installed gain (under actual process load conditions) as a means to improve process loop performance. Although it is possible to measure many of these dynamic performance parameters in an open loop situation, the impact these parameters have becomes clear when closed-loop performance is measured. The closed-loop test results shown in Figure 2.7 demonstrate the ability of three different valves to reduce process variability over different tuning conditions.

This diagram plots process variability as a percent of the set point variable versus the closed-loop time constant, which is a measure of loop tuning.

The horizontal line labeled “Manual”, shows how much variability is inherent in the loop when no attempt is made to control it (open loop). The line sloping downward to the left marked “Minimum Variability” represents the calculated dynamic performance of an ideal valve assembly (one with no non-linearities). All real valve assemblies should normally fall somewhere between these two conditions.

Not all valves provide the same dynamic performance even though they all theoretically meet static performance purchase specifications and are

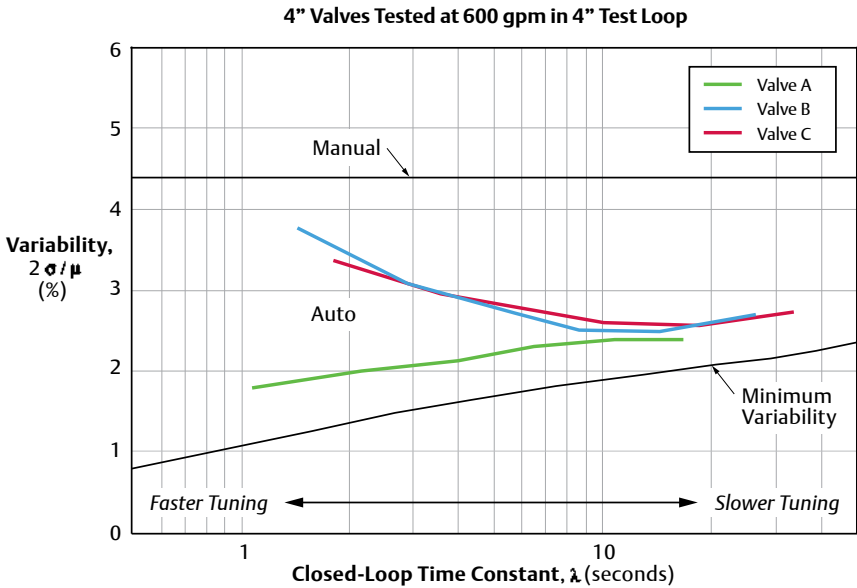

Figure 2.7 Closed Loop Random Load Disturbance Summary

considered to be equivalent valves (Figure 2.7). Valve A in Figure 2.7 does a good job of following the trend of the minimum variability line over a wide range of controller tunings. This valve shows excellent dynamic performance with minimum variability. In contrast, Valves B and C designs don't fare as well and increase in variability as the system is tuned more aggressively for decreasing closed-loop time constants.

All three valve designs are capable of controlling the process and reducing the variability, but two designs don't do it as well. Consider what would happen if the poorer performing Valve B was replaced with the best performing Valve A, and the system was tuned to a 2.0 second closed-loop time constant.

The test data shows this would result in a 1.4% improvement in process variability. This might not seem like much, but the results over a time can be impressive. A valve that can provide this much improvement every minute of

every day can save significant dollars over a single year.

The performance of the better valve in this example provides strong evidence that a superior control valve assembly can have a profound economic impact. This example is only one way a control valve can increase profits through tighter control. Decreased energy costs, increased throughput, less reprocessing cost for out-of-specification product, and so on, are all ways a good control valve can increase economic results through tighter control. While the initial cost might be higher for the best control valve, the few extra dollars spent on a well-engineered control valve can dramatically increase the return on investment. Often the extra initial cost of the valve can be paid for in a matter of days.

As a result, the process industries have become increasingly aware that control valve assemblies play an important role in loop/unit/plant performance. They have also realized that traditional

methods of specifying a valve assembly are no longer adequate to ensure the benefits of process optimization. While important, such static performance indicators as flow capacity, leakage, materials compatibility, and bench performance data are not sufficiently adequate to deal with the dynamic characteristics of process control loops. ■

ends with optimization of the entire loop. Parts of the loop cannot be treated individually to achieve coordinated loop performance. Likewise, performance of any part of the loop cannot be evaluated in isolation. Isolated tests under non-loaded, bench-type conditions will not provide performance information that is obtained from testing the hardware under actual process conditions. ■

## 2.3 Summary

The control valve assembly plays an extremely important role in producing the best possible performance from the control loop. Process optimization means optimizing the entire process, not just the control algorithms used in the control room equipment. The valve is called the final control element because the control valve assembly is where process control is implemented. It makes no sense to install an elaborate process control strategy and hardware instrumentation system capable of achieving 0.5% or better process control and then to implement that control strategy with a 5% or worse control valve. Audits performed on thousands of process control loops have provided strong proof that the final control element plays a significant role in achieving true process optimization. Profitability increases when a control valve has been properly engineered for its application.

Control valves are sophisticated, high-tech products and should not be treated as a commodity. Although traditional valve specifications play an important role, valve specifications must also address real dynamic performance characteristics if true process optimization is to be achieved. It is imperative that these specifications include such parameters as deadband, dead time, response time, etc.

Finally, process optimization begins and





# Chapter 3

## Valve and Actuator Types



## 3.1 Control Valve Styles

The control valve regulates the rate of fluid flow as the position of the valve closure member is changed by force from the actuator. To do this, the valve must:

- Contain the fluid without external leakage;
- Have adequate capacity for the intended service;
- Be capable of withstanding the erosive, corrosive, and temperature influences of the process; and
- Incorporate appropriate end connections to mate with adjacent pipelines and actuator attachment means to permit transmission of actuator thrust to the valve stem or shaft.

Many styles of control valve bodies have been developed through the years. Some have found wide application, while others meet specific service conditions and are used less frequently. The following summary describes some popular control valve body styles in use today. ■

### 3.1.1 Globe Valves

#### 3.1.1.1 Single-Port Valve Bodies

- Single port is the most common valve body style and is simple in construction.
- Single-port valves are available in various forms, such as globe, angle, bar stock, forged, and split constructions.
- Many single-seated valve bodies use cage or retainer-style construction to retain the seat-ring, provide valve plug guiding, and provide a means for establishing particular valve flow characteristics.
- Cage or retainer-style single-seated valve bodies can also be easily modified by change of trim parts to

change the flow characteristic or provide reduced-capacity flow, noise attenuation, or reduction or elimination of cavitation.

- Angle valves (Figure 3.1) are commonly used in boiler feedwater and heater drain service and in piping schemes where space is at a premium and the valve can also serve as an elbow. The valve shown has cage-style construction. Others might have expanded outlet connections, restricted trim, or outlet liners for reduction of erosion, flashing, or cavitation damage.



Figure 3.1 Flanged Angle-Style Control Valve Body

- Alloy valve bodies are often specified for corrosive applications (see Figure 3.2). They can be made from bar stock, castings, or forgings. When exotic metal alloys are required for corrosion resistance, sometimes a bar stock valve body is less expensive than a cast valve body. A valve with a polymer liner may also be used.
- High-pressure valves are often used in the hydrocarbon and power industries and are available to CL4500 or API 10,000. These can be globe or angle designs and typically have optional specialized trim for

severe service applications.

- High-pressure stem-guided globe valves are often used in production of gas and oil. Variations available include a threaded bonnet and self-draining angle. Flanged versions are available with ratings to Class 2500.

### 3.1.1.2 Post- and Port-Guided Valve Bodies

- Generally specified for applications with stringent shutoff requirements. They use metal-to-metal seating surfaces or soft seating with PTFE or other composition materials forming the seal. They can handle most service requirements.
- Because high-pressure fluid is normally loading the entire area of the port, the unbalanced force created must be considered in selecting actuators for post- and port-guided control valve bodies.
- Although most popular in the smaller sizes, post- and port-guided valves can often be used in NPS 4-8 (DN 100-200) sizes with high-thrust actuators.
- They can be susceptible to high-pressure drop vibration, so care is

needed with the design to avoid this.

Figure 3.3 shows one of the more popular styles of post-guided globe-type control valve bodies. They are widely used in process control applications, particularly in NPS 1-4 (DN 20-100).

Normal flow direction is most often up through the seat ring.

### 3.1.1.3 Cage-Style Valve Bodies

Cage-style trim (Figure 3.4) provides valve plug guiding, seat ring retention, and flow characterization.

In addition, a variety of seal materials and styles are available to seal between the upper portion of the valve plug's outer diameter and the cage bore to limit leakage of the upstream, high-pressure fluid into the lower pressure downstream system. In balanced designs, downstream pressure acts on both the top and bottom sides of the valve plug, which nullifies most of the static unbalanced force. Reduced unbalanced force permits operation of the valve with smaller actuators than those necessary for unbalanced valve trim. Interchangeability of trim permits choice of several flow characteristics, noise attenuation, anti-cavitation, or



Figure 3.2 Bar Stock Valve Body

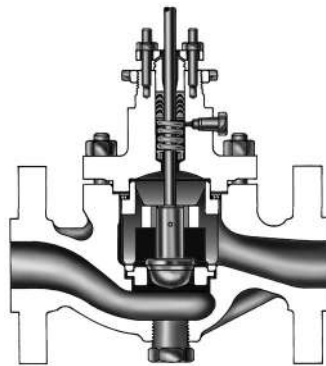

Figure 3.3. Single-Ported Globe-Style Valve Body

other severe service capability. For most available trim designs, the standard direction of flow is in through the cage openings and down through the seat ring. However, noise attenuation trim is typically flow up. These are available in various material combinations, sizes through NPS 36 (DN 900), and pressure ratings up to Class 4500 or API 10,000.

### 3.1.1.4 Double-Ported Valve Bodies

- The industry has predominantly moved away from using double-ported valve designs.
- Dynamic force on the plug tends to be balanced as flow tends to open one port and close the other.
- Reduced dynamic forces acting on the plug might permit choosing a smaller actuator than would be necessary for a single-ported unbalanced valve body with similar capacity.
- Bodies are usually furnished only in NPS 4 (DN 100) or larger.
- Bodies normally have higher capacity than single-ported valves of the same line size.
- Many double-ported bodies reverse, so the valve plug can be installed as either push-down-to-open or

push-down-to-close (Figure 3.5).

- Metal-to-metal seating usually provides Class II shutoff capability, although Class III capability is also possible.
- Port-guided valve plugs are often used for on/off or low-pressure throttling service. Top- and bottom-guided valve plugs furnish stable operation for severe service conditions.

The control valve body shown in Figure 3.5 is assembled for push-down-to-open valve plug action.

Double-ported designs were historically used in refineries on highly viscous fluids or where there was a concern about contaminants or process deposits on the trim.

### 3.1.1.5 Three-Way Valve Bodies

- Three pipeline connections provide general converging (flow-mixing) or diverging (flow-splitting) service.
- Variations include cage-, port-, and stem-guided designs, selected for high-temperature service, and standard end connections (flanged, screwed, butt weld, etc.) can be specified to mate with most any

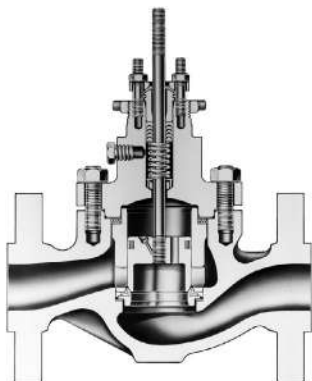

Figure 3.4 Valve Body with Cage-Style Trim, Balanced Valve Plug, and Soft Seat

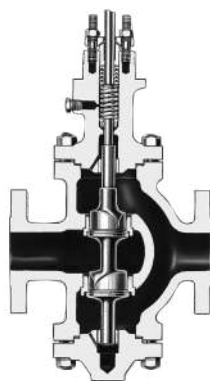

Figure 3.5 Reverse-Acting Double-Ported Globe-Style Valve Body

pipng scheme.

- Actuator selection demands careful consideration, particularly for constructions with an unbalanced valve plug.

In Figure 3.6, a three-way valve body with a balanced valve plug is shown with the cylindrical valve plug in the mid-travel position. This position opens the bottom common port to both the right-hand port and left-hand port. The construction can be used for throttling mid-travel position control of either converging or diverging fluids.



Figure 3.6 Three-Way Globe Valve

### 3.1.2 Sanitary Valves

These valve body styles are designed to satisfy the stringent demands of the pharmaceutical and biotechnology industries. The standards of these industries differ from those that apply to conventional control valve designs because in many applications, the process fluid will ultimately be for human consumption. For this reason, it is of utmost importance to prevent the development of bacterial growth and the addition of foreign matter into the process fluid.

- ASME-BPE sliding and non-sliding seals have been incorporated to satisfy a broad range of aseptic

applications. Certifications are available.

- Metallic materials used in these valves satisfy 3A Sanitary Standards. Certifications are available.
- Elastomers used in these valve designs are certified per FDA and USP CL VI.
- Valves are available with <35 Ra microinch (0.89 Micron) electro-polished internal surfaces as standard. Other lesser values for surface roughness are available as options.
- Self-draining designs make these valves well suited for Clean-in-Place (CIP) and Steam-in-Place (SIP) applications.
- Valves are machined 316L stainless steel with tri-clamp or optional butt weld-ends. Other materials are available as options.
- Continuous sterile steam applications with temperatures up to 177°C (350°F) can be accommodated.

## 3.1.3 Rotary Valves

### 3.1.3.1 Butterfly Valve Bodies

- Bodies require minimum space for installation (Figure 3.7).
- They provide with low pressure loss through the valves.
- Butterfly valve bodies offer economy, particularly in larger sizes and flow capacity per investment dollar.
- Bodies mate with standard raised-face ASME and DN flanges.
- Butterfly valve bodies might require high-output or large actuators if the valve is big or the pressure drop is high because operating torques might be quite large.
- Units are available for service in nuclear power plant applications with very stringent leakage

requirements.

- Standard butterfly valves are available in sizes through NPS 72 (DN 1800) for miscellaneous control valve applications. Smaller sizes can use versions of traditional diaphragm or piston pneumatic actuators, including the modern rotary actuator styles. Larger sizes might require high-output electric, long-stroke pneumatic cylinder, or electro-hydraulic actuators. Butterfly valves typically exhibit an approximately equal-percentage flow characteristic. They can be used for throttling service or for on/off control.



Figure 3.7 Butterfly Control Valve

### 3.1.3.2 Segmented Ball Valve Bodies

This construction is similar to a conventional ball valve, but with a patented, contoured V-notch segment in the ball (Figure 3.8). The V-notch produces an equal-percentage flow characteristic.

These control valves have good rangeability, control, and shutoff capability. The paper industry, chemical plants, sewage treatment plants, the power industry, and petroleum refineries use such valve designs.

- Straight-through flow design can accommodate small pressure drop.
- V-notch ball control valve bodies are suited to control erosive or viscous

fluids, paper stock, or other slurries containing entrained solids or fibers.



Figure 3.8 Segmented V-Notch Ball

- They use standard spring-and-diaphragm, piston, electric, or electro-hydraulic rotary actuators.
- The ball remains in contact with the seal during rotation, which produces a shearing effect as the ball closes and minimizes clogging.
- Bodies are available with either heavy-duty or PTFE-filled composition ball seal ring to provide excellent rangeability in excess of 300:1.
- Segmented ball control valves are available in flangeless or flanged-body end connections.
- Both flanged and flangeless valves mate with ASME Class 150, 300, or 600 flanges. Designs are also available for DN flanges, PN10, 16, 25, or 40. JIS 10K and 20K flanged designs are also available.

### 3.1.3.3 High-Performance Butterfly Valve Bodies

- These bodies offer effective throttling control.
- High-performance butterfly control valve bodies provide linear flow characteristic through 90 degrees of disk rotation (Figure 3.9).
- Double offset mounting of disk pulls it away from the seal after it begins to open, minimizing seal wear.
- High-performance butterfly control



valve bodies are available in sizes through NPS 24 (DN 600) compatible with standard ASME flanges.



Figure 3.9 High-Performance Butterfly Control Valve

- They use standard spring-and-diaphragm, piston, electric, or electro-hydraulic rotary actuators.
- Standard flow direction is dependent on seal design; reverse flow results in reduced capacity.

High-performance butterfly control valves are intended for general service applications not requiring precision throttling control. They are frequently used in applications requiring large sizes and high temperatures due to their lower cost relative to other styles of control valves. The control range for this style of valve is approximately one third as large as ball or globe-style valves. Consequently, additional care is required in sizing and applying this style of valve to eliminate control problems associated with process load changes. They work quite well for constant process load applications. Designs using characterized contour are able to expand the control range to that of a segmented ball valve.

### 3.1.3.4 Eccentric Plug Valve Bodies

- Valve assembly combats erosion. The rugged body and trim design handle temperatures to 427°C (800°F) and shutoff pressure drops to 1500 psi (103 bar).
- The path of the eccentric disk minimizes contact with the seat ring

when opening, reducing seat wear and friction, prolonging seat life, and improving throttling performance (Figure 3.10).

- Self-centering seat ring and rugged disk allow forward or reverse flow with tight shutoff in either direction. Disk, seat ring, and retainer are available in hardened materials, including ceramics, for selection of erosion resistance.
- Plug, seat ring, and retainer are available in hardened materials, including ceramics and carbides, for improved selection of erosion resistance.
- Designs offering a segmented V-notch ball in place of the plug for higher capacity requirements are available.

This style of rotary control valve suits erosive, coking, and other hard-to-handle fluids, providing either throttling or on/off operation. The flanged or flangeless valves feature streamlined flow passages and rugged, metal trim components for dependable service in slurry applications. These valves are used in mining, petroleum refining, power, and pulp and paper industries. ■



Figure 3.10 Eccentric Plug Control Valve Body



### 3.1.3.5 Full-Port Ball Valve Bodies

The full-port ball control valve is designed for optimized pressure, throttling, flow and process control. Typically, there is an option for attenuation to control noise and vibration. A ball valve as a throttling control device ideally is a reduced bore product, or full-bore mechanism with an attenuator that absorbs some small pressure drop in the wide-open position. A full-port ball valve, in the wide-open position, must rotate 15 to 20 degrees before absorbing any significant energy from the system, this relates to additional process control lag. A reduced bore or attenuated device absorbs a small amount of pressure wide open; as the ball rotates, increasing pressure drop occurs in the first increments of travel. Full port ball valves present little or no restriction to flow and allow for pigging (when not attenuated). See Figure 3.11.



Figure 3.11 Full-Port Ball Control Valve

### 3.1.3.6 Multi-Port Flow Selector

A multi-port flow selector valve connects to eight input lines, allowing for the isolation, diversion, and testing of fluid from any individual line through a rotating plug, while the remaining seven lines continue to flow to a common group outlet. This valve provides compact selection and diversion of fluids from an individual

line for testing without disrupting the production from all other lines.

The multi-port flow selector consists of four main components: the body, bonnet, rotor plug, and actuator. The body consists of inlet and outlet ports to connect all the eight inlets, one test or diversion outlet, and common group outlet. The bonnet will hold the plug vertically, balanced to rotate within the body, and provides tight sealing to the valve body. The plug is used to select which media port is sent through the test outlet port. See Figure 3.12.



Figure 3.12 Multi-Port Flow Selector Valve

## 3.2 Control Valve End Connections

The three most common methods of installing control valves into pipelines are by means of screwed pipe threads, bolted gasketed flanges, and welded end connections.

### 3.2.1 Screwed Pipe Threads

Screwed end connections, popular in small control valves, offer more economy than flanged ends. The threads usually specified are tapered female NPT (National Pipe Thread) on the valve body. They form a metal-to-metal seal

by wedging over the mating male threads on the pipeline ends.

This connection style, usually limited to valves NPS 2 (DN 50) or smaller, is not recommended for elevated temperature service. Valve maintenance might be complicated by screwed end connections if it is necessary to take the body out of the pipeline because the valve cannot be removed without breaking a flanged joint or union connection to permit unscrewing the valve body from the pipeline.

### 3.2.2 Bolted Gasketed Flanges

Flanged end valves are easily removed from the piping and are suitable for use through the range of working pressures for which most control valves are manufactured (Figure 3.13). Flanged end connections can be used in a temperature range from near absolute zero to approximately 815°C (1500°F). They are used on all valve sizes. The most common flanged end connections include flat-face, raised-face, and ring-type joint.

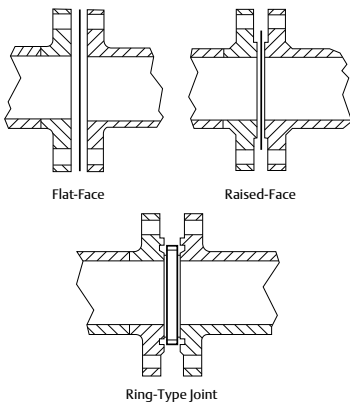

Figure 3.13 Popular Varieties of Bolted Flange Connections

The flat-face variety allows the matching flanges to be in full-face contact with the gasket clamped between them. This

construction is commonly used in low pressure, cast iron, and brass valves and minimizes flange stresses caused by initial bolting-up force.

The raised-face flange features a circular raised face with inside diameter the same as the valve opening and with the outside diameter something less than the bolt circle diameter. The raised face is finished with concentric circular grooves for good sealing and resistance to gasket blowout. This kind of flange is used with a variety of gasket materials and flange materials for pressures through the 6000 psig (414 bar) pressure range and for temperatures through 815°C (1500°F). This style of flanging is normally standard on Class 250 cast iron bodies and all steel and alloy steel bodies.

The ring-type joint flange looks like the raised-face flange except that a U-shaped groove is cut in the raised face concentric with the pipe centerline. The gasket consists of a metal ring with either an elliptical or octagonal cross section. When the flange bolts are tightened, the gasket is wedged into the groove of the mating flanges and a tight seal is made. The gasket is generally soft iron but is available in almost any metal. This makes an excellent joint at high pressure and is used up to 15,000 psig (1034 bar), but is generally not used at high temperatures. It is furnished only on steel and alloy valve bodies when specified.

### 3.2.3 Welded End Connections

Welded ends on control valves are leak-tight at all pressures and temperatures and are economical in first cost (Figure 3.14). Weld-end valves are more difficult to take from the line and are obviously limited to weldable materials. Welded ends come in two styles: socket weld and butt weld.

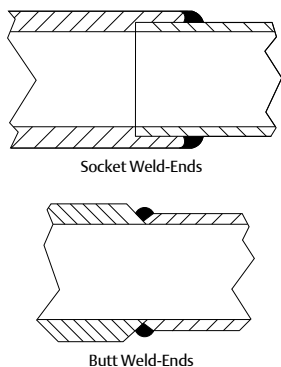

Figure 3.14 Common Welded End Connections

The socket weld-ends are prepared by boring in each end of the valve a socket with an inside diameter slightly larger than the pipe outside diameter. The pipe slips into the socket where it butts against a shoulder and then joins to the valve with a fillet weld. Since a fillet weld does not fully penetrate the valve-pipe connection, some non-destructive methods are not used for these valves. Socket weld ends in any given size are dimensionally the same regardless of pipe schedule. They are usually furnished in sizes through NPS 2 (DN 50).

The butt weld-ends are prepared by beveling each end of the valve to match a similar bevel on the pipe. The valve ends are then joined to the pipeline and joined with a full-penetration weld. This type of joint can be used on all valve styles. The end preparation is different for each schedule of pipe. These are generally furnished for control valves in sizes NPS 2-1/2 (DN 65) and larger. Care must be exercised when welding valve bodies in the pipeline to prevent excessive heat transmitted to valve trim parts. Trims with low-temperature composition materials must be removed before welding.

### 3.2.4 Other Valve End Connections

There are other types of end connections used with control valves. These types of end connections often serve specific purposes or reflect proprietary designs. Some examples include hygienic end connections or hub end connections. ■

## 3.3 Valve Body Bonnets

The bonnet of a control valve is that part of the body assembly through which the valve plug stem or rotary shaft moves. On globe or angle bodies, it is the pressure-retaining component for one end of the valve body. The bonnet normally provides a means of mounting the actuator to the body and houses the packing box.

Generally, rotary valves do not have bonnets. (On some rotary valves, the packing is housed within an extension of the valve body itself, or the packing box is a separate component bolted between the valve body and bonnet.)

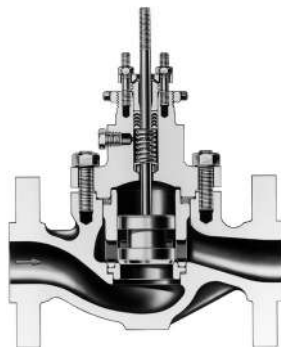

Figure 3.15 Typical Bonnet, Flange, and Stud Bolts

On a typical globe-style control valve body, the bonnet is made of the same material as the valve body or is an equivalent forged material because it is a pressure-containing member subject to the same temperature and corrosion effects as the body. Several styles of

valve body-to-bonnet connections are illustrated. The most common bolted flange type is shown in Figure 3.15 of a bonnet with an integral flange. In rotary control valves, the packing is typically housed within the valve body and a bonnet is not used.

On control valve bodies with cage- or retainer-style trim, the bonnet furnishes loading force to prevent leakage between the bonnet flange and the valve body and also between the seat ring and the valve body. The tightening of the body-bonnet bolting compresses a flat sheet gasket to seal the body-bonnet joint, compresses a spiral-wound gasket on top of the cage, and compresses another flat sheet gasket below the seat ring to provide the seat ring-body seal. The bonnet also provides alignment for the cage, which, in turn, guides the valve plug, to ensure proper valve, plug, and stem alignment with the packing and seating.

As mentioned, the conventional bonnet on a globe-type control valve houses the packing. The packing is most often retained by a packing-follower, held in place by a flange on the yoke boss area of the bonnet (Figure 3.15). An alternate means of packing retention is where the packing-follower is held in place by a screwed gland. This alternate is compact, so it is often used on small control valves; however, the user cannot always be sure of thread engagement. Therefore, caution should be used in adjusting packing compression when the control valve is in service.

Most bolted-flange bonnets have an area on the side of the packing box which can be drilled and tapped. This opening is closed with a standard pipe plug unless one of the following conditions exists:

- It is necessary to purge the valve body and bonnet of process fluid, in which case the opening can be used as a purge connection.
- The bonnet opening is being used to detect leakage from the first set of packing or from a failed bellows seal.

### 3.3.1 Extension Bonnets

Extension bonnets are used for either high or low temperature service to protect valve stem packing from extreme process temperatures. Standard PTFE valve stem packing is useful for most applications up to 232°C (450°F). Extension bonnets move the packing box of the bonnet far enough away from the extreme temperature of the process that the packing temperature remains within the recommended range.

Extension bonnets are either cast or fabricated (Figure 3.16). Cast extensions offer better high-temperature service because of greater heat emissivity, which provides better cooling effect. Conversely, smooth surfaces—such as those fabricated from stainless steel tubing—are preferred for cold service because heat influx is typically the major concern.



Figure 3.16 Valve Body with Fabricated Extension Bonnet

In either case, extension wall thickness should be minimized to cut down heat transfer. Stainless steel is usually preferable to carbon steel because of its lower coefficient of thermal conductivity. In cold service applications, insulation can be added around the extension to protect further against heat influx.

### 3.3.2 Bellows Seal Bonnets

Bellows seal bonnets (Figure 3.17) are used when no leakage (less than  $1 \times 10^{-6}$  cc/sec of helium) along the stem can be tolerated. They are often used when the process fluid is toxic, volatile, radioactive, or very expensive. This special bonnet construction protects both the stem and the valve packing from contact with the process fluid. Standard or environmental packing box constructions above the bellows seal unit will prevent catastrophic failure in case of rupture or failure of the bellows.



Figure 3.17 ENVIRO-SEAL Bellows Seal Bonnet

As with other control valve pressure and temperature limitations, these pressure

ratings decrease with increasing temperature. Selection of a bellows seal design should be carefully considered with particular attention to proper inspection and maintenance after installation. The bellows material should be carefully considered to ensure the maximum cycle life.

Two types of bellows seal designs can be used for control valves. These are welded-leaf and mechanically-formed bellows.

The welded-leaf design (Figure 3.18) offers a shorter total package height. Due to its method of manufacture and inherent design, service life may be limited.

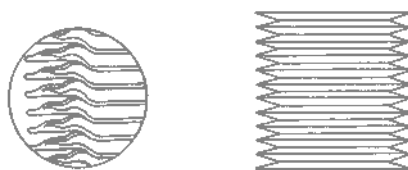

Figure 3.18 Welded-Leaf Bellows

The mechanically-formed design (Figure 3.19) is taller by comparison and is produced with a more repeatable manufacturing process and, therefore, higher reliability. ■

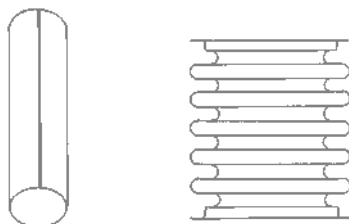

Figure 3.19 Mechanically-Formed Bellows

## 3.4 Control Valve Packing

Most control valves use packing boxes with the packing retained and adjusted by a flange and stud bolts (shown in Figure 3.26). Several packing materials can be used, depending on the service conditions expected and whether the

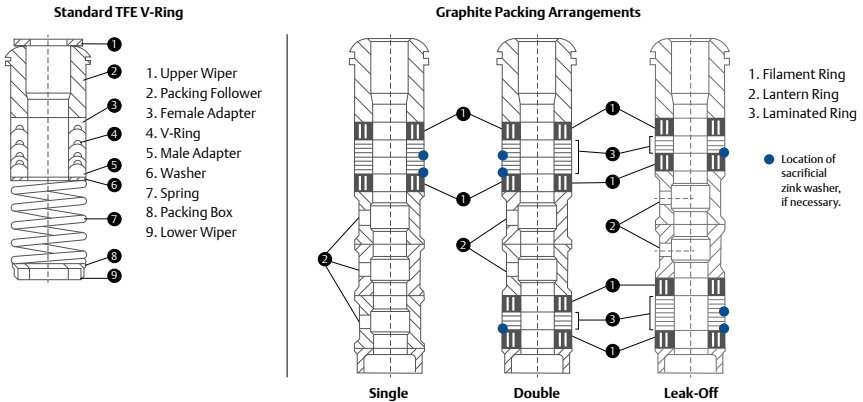

Figure 3.20 Packing Material Arrangements for Globe-Style Valve Bodies

application requires compliance to environmental regulations. Brief descriptions and service condition guidelines for several popular materials and typical packing material arrangements are shown in Figure 3.20.

### 3.4.1 PTFE V-Ring

- Plastic material with inherent ability to minimize friction.
- Molded in V-shaped rings that are spring-loaded and self-adjusting in the packing box. Packing lubrication is not required.
- Resistant to most known chemicals, except molten alkali metals.
- Requires extremely smooth (2 to 4 micro-inches RMS) stem finish to seal properly. Will leak if stem or packing surface is damaged.
- Recommended temperature limits: -40 to 232°C (-40 to 450°F)
- Not suitable for nuclear service because PTFE is easily destroyed by radiation.

### 3.4.2 Laminated and Filament Graphite

- Suitable for high-temperature nuclear service or where low chloride

content is desirable (Grade GTN).

- Provides leak-free operation, high-thermal conductivity, and long service life, but produces high stem friction and resultant hysteresis.
- Impervious to most hard-to-handle fluids and high radiation.
- Suitable temperature range: cryogenic temperatures down to -198°C (-325°F)
- Lubrication is not required, but an extension bonnet or steel yoke should be used when packing box temperature exceeds 427°C (800°F).

### 3.4.3 U.S. Regulatory Requirements for Fugitive Emissions

Fugitive emissions are non-point source volatile organic emissions which result from process equipment leaks.

Equipment leaks in the United States have been estimated at over 400 million pounds per year. Strict government regulations, developed by the US, dictate leak detection and repair programs (LDAR). Valves and pumps have been identified as key sources of fugitive emissions. For valves, this is the leakage to atmosphere due to packing seal or gasket failures.

The LDAR programs require industry to

monitor all valves (control and non-control) at an interval that is determined by the percentage of valves found to be leaking above a threshold level of 500 ppmv (some cities use a 100 ppmv criteria). This leakage level is so slight you cannot see or hear it. The use of sophisticated portable monitoring equipment is required for detection. Detection occurs by sniffing the valve packing area for leakage using an Environmental Protection Agency (EPA) protocol. This is a costly and burdensome process for industry.

The regulations do allow for the extension of the monitoring period for up to one year if the facility can demonstrate a very low ongoing percentage of leaking valves (less than 0.5% of the total valve population). The opportunity to extend the measurement frequency is shown in Figure 3.21.

Packing systems designed for extremely low leakage requirements also extend packing-seal life and performance to support an annual monitoring objective. The ENVIRO-SEAL packing system is one example. Its enhanced seals incorporate four key design principles: the containment of the pliable seal material through an anti-extrusion component, proper alignment of the valve stem or shaft within the bonnet bore, applying a constant packing stress through Belleville springs, and minimizing the number of

seal rings to reduce consolidation, friction, and thermal expansion.

The traditional valve selection process meant choosing a valve design based on its pressure and temperature capabilities, flow characteristics, and material compatibility. Which valve stem packing to use in the valve was determined primarily by the operating temperature in the packing box area. The available material choices included PTFE for temperatures below 93°C (200°F) and graphite for higher-temperature applications.

Today, choosing a valve packing system has become much more involved due to a number of considerations.

### 3.4.4 Global Standards for Fugitive Emissions

ISO 15848 is the International Organization for Standardization's (ISO) standard for measurement, test, and qualification procedures for fugitive emissions of industrial valves. ISO 15848-1 is a classification system and qualification for type testing of valves that was created to enable classification of performance of different fugitive emission designs and to define the type test for evaluation and qualification of valves where fugitive emissions standards are specified.

Type testing means that the qualification

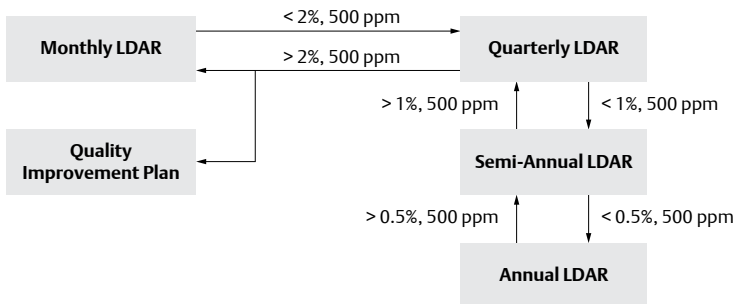

Figure 3.21 Measurement Frequency for Valves Controlling Volatile Organic Chemicals (VOC)

test is performed on one valve and packing system design and any qualification is passed on to all valves produced to that packing design. Type testing differs from ISO 15848-2 production testing, which is a qualification test done at the time of assembly and can be dictated for more than one valve assembly.

ISO 15848-1 covers both control valves and isolation (on/off) valves. The mechanical cycle requirements for the two types of valves differ, as shown in Figure 3.22. Mechanical cycles are performed at 10% of full travel on both sides of the 50% travel position for control valves and full stroke for isolation valves.

Like other fugitive emission standards, ISO 15848-1 lays out a qualification test that includes several combinations of leakage classes, thermal cycles, and mechanical cycles. There are several notable differences between ISO 15848-1 and government requirements and standards of US origin such as LDAR and ANSI/FCI 91-1 standard for qualification of control valve stem seals.

Valve Type	Mechanical Cycle Class	Mechanical Cycles Required	Temp. Cycles
Control Valve	CC1	20,000	2
	CC2	60,000	3
	CC3	100,000	4
Isolation Valve	CO1	205	2
	CO2	1,500	3
	CO3	2,500	4

Figure 3.22 ISO 15848-1 Qualification Requirements

ANSI/FCI 91-1 requires the “sniffing method” per EPA Method 21 for a “ppm” concentration reading and cites 100ppm and 500ppm with various cycle classes, as shown in Figure 3.25.

ISO 15848-1 specifies either the vacuum or flushing “total leakage” measurement methods described in Annex A of the standard.

Leakage is recorded as a leakage rate per measured stem size. Neither of these methods can be correlated with EPA Method 21 (sniffing method) and ISO 15848-1 states there is no correlation intended between the tightness classes when the test fluid is helium and when the test fluid is methane. See Figures 3.23 and 3.24.

ISO 15848-1 Leakage Tightness Classes	Measured Leak Rate (Annex A)	
	mg.s-1.m-1 of stem perimeter	atm.cm3.s-1. mm-1 of stem diameter
AH	$< 10^{-5}$	$< 1.76 \times 10^{-7}$
BH	$< 10^{-4}$	$< 1.76 \times 10^{-6}$
CH	$< 10^{-2}$	$< 1.76 \times 10^{-4}$

*Note: Leakage Class A is typically achieved only with Bellows designs.*

*Note: Leakage classes may be denoted by “BH” or “BM”, etc to indicate the testing fluid. “H” indicates the test was performed with Helium per a leakage rate method. “M” indicates the test was performed with Methane using EPA Method 21.*

Figure 3.23 ISO 15848-1 Measured Leak Rate

ISO 15848-1 Leakage Tightness Classes	Measured Leak Concentration (Annex B Sniffing Method per EPA Method 21)
AM	$< 50\text{ppm}$
BM	$< 100\text{ppm}$
CM	$< 500\text{ppm}$

*Note: Leakage Class A is typically achieved only with bellows designs.*

*Note: Leakage classes may be denoted by “BH” or “BM”, etc to indicate the testing fluid. “H” indicates the test was performed with Helium per a leakage rate method. “M” indicates the test was performed with Methane using EPA Method 21.*

Figure 3.24 ISO 15848-1 Measured Leak Concentration

Today, choosing a valve packing system has become much more involved due to



Class	Mechanical Cycles (100% full travel)	Thermal Cycles	Maximum Stem Seal Leakage per EPA Method 21
A1	100,000	3	100 ppm
A2	100,000	3	500 ppm
B1	25,000	3	100 ppm
B2	25,000	3	500 ppm

Figure 3.25 FCI 91-1 Leakage Class Summary

a number of considerations.

For example, emissions control requirements—such as those specified by the Clean Air Act within the US and ISO 15848 on a global basis—place tighter restrictions on sealing performance. Constant demands for improved process output mean that the valve packing system must not hinder valve performance. And today's trend toward extended maintenance schedules dictates that valve packing systems provide the required sealing over longer periods.

Given the wide variety of valve applications and service conditions within industry, these variables (sealing ability, operating friction levels, operating life) are difficult to quantify and compare. Figures 3.31 and 3.32 use an engineered approach in providing a relative evaluation of packing applicability and performance. But first, proper understanding of the tables requires a clarification of trade names.

### 3.4.5 Single PTFE V-Ring Packing

The single PTFE V-ring arrangement uses a coil spring between the packing and packing box ring. It meets the 100 ppmv criteria for sliding-stem valves, assuming that the pressure does not exceed 300 psi (20.7 bar) and the temperature is between -18°C and 93°C (0°F and 200°F). Single PTFE V-ring packing does not come with low emissions criteria for rotary valves. It offers very good sealing

performance with the lowest operating friction. See Figure 3.26.

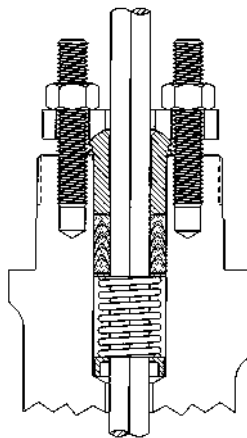

Figure 3.26 Single PTFE V-Ring Packing

### 3.4.6 ENVIRO-SEAL PTFE Packing

The ENVIRO-SEAL PTFE packing system is an advanced packing method that utilizes a compact, live-load spring design suited to environmental applications up to 750 psi and 232°C (51.7 bar and 450°F). While it is typically thought of as an emission-reducing packing system, ENVIRO-SEAL PTFE packing is also suited to non-environmental applications involving high temperatures and pressures, yielding the benefit of longer, ongoing service life in both sliding-stem and rotary valves. See Figure 3.27.

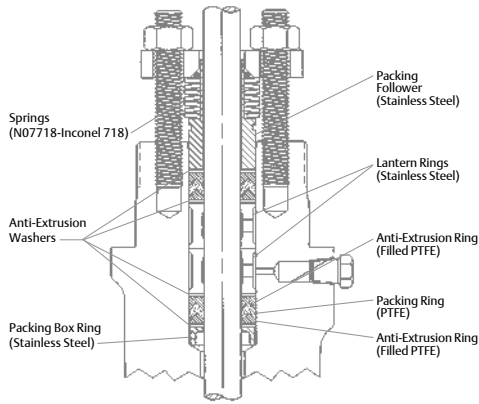

Figure 3.27 ENVIRO-SEAL PTFE Packing System

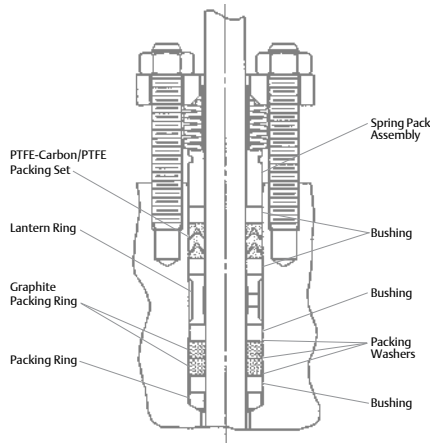

Figure 3.28 ENVIRO-SEAL Duplex (PTFE and Graphite) Packing System

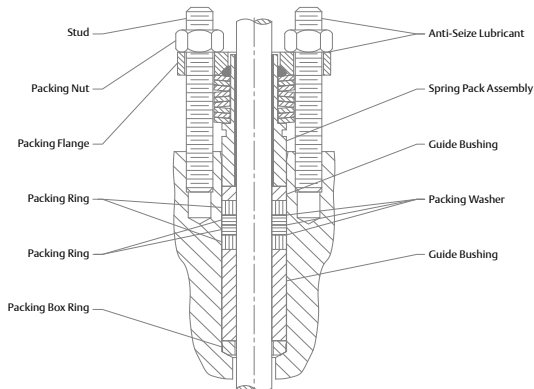

Figure 3.29 ENVIRO-SEAL Graphite ULF Packing System

### 3.4.7 ENVIRO-SEAL Duplex Packing

This special packing system provides the capabilities of both PTFE and graphite components to yield a low friction, low emission, fire-tested solution (API Standard 589) for applications with process temperatures up to 232°C (450°F) in sliding-stem valves. Rotary valves are not available with ENVIRO-SEAL Duplex packing. See Figure 3.28.

### 3.4.8 ISO-Seal PTFE Packing

This packing system is designed for pressures exceeding the capabilities of ENVIRO-SEAL PTFE packing for environmental service. It is available for use in both sliding-stem and rotary valves.

### 3.4.9 ENVIRO-SEAL Graphite ULF

This packing system is designed primarily for environmental applications at temperatures in excess of 232°C (450°F). The patented ULF packing system incorporates very thin PTFE layers inside the packing rings as well as thin PTFE washers on each side of the packing rings. This strategic placement of PTFE minimizes control problems, reduces friction, promotes sealing and extends the cycle life of the packing set. See Figure 3.29.

### 3.4.10 HIGH-SEAL Graphite ULF

Identical to the ENVIRO-SEAL graphite ULF packing system below the packing-follower, the HIGH-SEAL system utilizes heavy-duty, large diameter Belleville springs. These springs provide additional follower travel and can be calibrated with a load scale for a visual indication of packing load and wear.

### 3.4.11 ISO-Seal Graphite Packing

This packing system is designed for temperatures exceeding the capabilities of ENVIRO-SEAL Graphite ULF packing. It can be used from -46 to 400°C (-50 to

752°F) for environmental service. It is available for use in both sliding-stem and rotary valves.

### 3.4.12 ENVIRO-SEAL Graphite for Rotary Valves

ENVIRO-SEAL graphite packing is designed for environmental applications from -6 to 316°C (20 to 600°F) or for those applications where fire safety is a concern. It can be used with pressures up to 1500 psi (103 bar) and still satisfy the 100 ppmv EPA leakage criteria. The packing can be used up to 371°C (700°F) if used in non-environmental applications. See Figure 3.30.

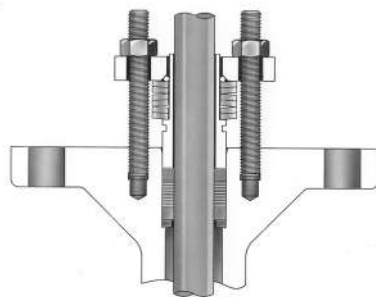

Figure 3.30 ENVIRO-SEAL Graphite Packing System for Rotary Valves

### 3.4.13 Graphite Ribbon for Rotary Valves

Graphite ribbon packing is designed for non-environmental applications that span a wide temperature range, from -198 to 538°C (-325 to 1000°F).

### 3.4.14 Sliding-Stem Environmental Packing Selection

Figure 3.31 provides a comparison of various sliding-stem packing selections and a relative ranking of seal performance, service life, and packing friction for environmental applications. Braided graphite filament and double PTFE are not acceptable environmental sealing solutions.

Packing System	Maximum Pressure & Temperature Limits for Environmental Service <sup>(1)</sup>		Seal Performance Index	Service Life Index	Packing Friction
	Customary U.S.	Metric			
Single PTFE V-Ring	300 psi 0 to 200°F	20.7 bar -18 to 93°C	Better	Long	Very Low
ENVIRO-SEAL PTFE	750 psi -50 to 450°F	1.7 bar -46 to 232°C	Superior	Very Long	Low
ISO-Seal PTFE	6000 psig -50 to -450°F	414 bar -46 to 232°C	Superior	Very Long	Low
ENVIRO-SEAL Duplex	750 psi -50 to -450°F	51.7 bar -46 to 232°C	Superior	Very Long	Low
ENVIRO-SEAL Graphite ULF	1500 psi 20 to 600°F	103 bar -7 to 315°C	Superior	Very Long	Moderate
ISO-Seal Graphite	3365 psig -50 to 752°F	232 bar -46 to 400°C	Superior	Very Long	Moderate

1. The values shown are only guidelines. These guidelines can be exceeded, but shortened packing life or increased leakage might result. The temperature ratings apply to the actual packing temperature, not to the process temperature.

Figure 3.31 Sliding-Stem Environmental Packing Selection

Packing System	Maximum Pressure & Temperature Limits for Environmental Service <sup>(1)</sup>		Seal Performance Index	Service Life Index	Packing Friction
	Customary U.S.	Metric			
ENVIRO-SEAL PTFE	750 psi -50 to 450°F	103 bar -46 to 232°C	Superior	Very Long	Low
ENVIRO-SEAL Graphite	1500 psi 20 to 600°F	103 bar -18 to 315°C	Superior	Very Long	Moderate
ISO-Seal Graphite	1500 psig -50 to 752°F	103 bar -46 to 400°C	Superior	Very Long	Moderate

1. The values shown are only guidelines. These guidelines can be exceeded, but shortened packing life or increased leakage might result. The temperature ratings apply to the actual packing temperature, not to the process temperature.

Figure 3.32 Rotary Environmental Packing Selection



Figure 3.33 Characterized Cages for Globe-Style Valve Bodies

### 3.4.15 Rotary Environmental Packing Selection

Figure 3.32 applies to rotary valves. In the case of rotary valves, single PTFE and graphite ribbon packing arrangements do not perform well as fugitive emission sealing solutions.

The control of valve fugitive emissions and a reduction in industry's cost of regulatory compliance can be achieved through these stem sealing technologies. While ENVIRO-SEAL packing systems have been designed specifically for fugitive emission applications, these technologies also should be considered for any application where seal performance and seal life have been an ongoing concern or maintenance cost issue. ■

## 3.5 Characterization of Cage-Guided Valve Bodies

In valve bodies with cage-guided trim, the shape of the flow openings or windows in the wall of the cylindrical cage determines flow characterization. As the valve plug is moved away from the seat ring, the cage windows are opened to permit flow through the valve. Standard cages have been designed to produce linear, equal-percentage, and quick-opening inherent flow characteristics. Custom characterization may also be available. Note the differences in the shapes of the cage windows shown in Figure 3.33. The flow rate/travel relationship provided by valves using these cages is either the linear, quick-opening, or equal-percentage curves shown for contoured valve plugs (Figure 3.34).

Cage-guided trim allows for the inherent flow characteristic of the valve to be easily changed by installing a different cage. Interchange of cages to provide a different inherent flow characteristic does not require changing the valve plug or seat ring. The standard

cages shown can be used with either balanced or unbalanced trim constructions. Soft seating, when required, is available as a retained insert in the seat ring and is independent of cage or valve plug selection.

Cage interchangeability can be extended to specialized cage designs that provide noise attenuation or combat cavitation. These cages typically furnish a linear inherent flow characteristic, but require flow to be in a specific direction through the cage openings. Therefore, it could be necessary to reverse the valve body in the pipeline to obtain proper flow direction.

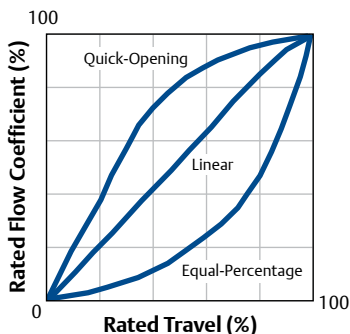

Figure 3.34 Inherent Flow Characteristics Curves

### 3.5.1 Characterized Valve Plugs

The valve plug, the movable part of a globe-style control valve assembly, provides a variable restriction to fluid flow. Valve plug styles are each designed to provide a specific flow characteristic, permit a specified manner of guiding or alignment with the seat ring, or have a particular shutoff or damage-resistance capability.

The contour of the valve plug surface next to the seat ring is instrumental in determining the inherent flow characteristic of a plug-characterized control valve. As the actuator moves the valve plug through its travel range, the unobstructed flow area changes in size and shape depending on the contour of

the valve plug. When a constant pressure differential is maintained across the valve, the changing relationship between percentage of maximum flow capacity and percentage of total travel range can be portrayed (Figure 3.34), and is designated as the inherent flow characteristic of the valve.

Commonly specified inherent flow characteristics include linear, equal-percentage, and quick-opening. These are described further in Chapter 5. ■

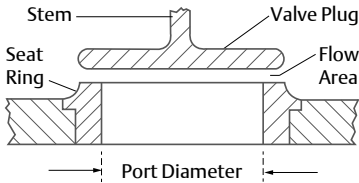

Figure 3.35 Typical Construction to Provide Quick-Opening Flow Characteristic

### 3.6 Valve Plug Guiding

Accurate guiding of the valve plug is necessary for proper alignment with the seat ring and efficient control of the process fluid. The common methods used and their names are generally self-descriptive.

**Cage-Guiding:** The outside diameter of the valve plug is close to the inside wall surface of the cylindrical cage throughout the travel range. Since the bonnet, cage, and seat ring are self-aligning on the assembly, correct valve plug and seat ring alignment is assured when the valve closes (Figure 3.15).

**Top-Guiding:** The valve plug is aligned by a single guide bushing in the bonnet or valve body, or by the packing arrangement.

**Stem-Guiding:** The valve plug is aligned with the seat ring by a guide bushing in the bonnet that acts on the valve plug stem.

**Top- and Bottom-Guiding:** The valve plug is aligned by guide bushings in the bonnet and bottom flange (see Figure 3.5). This is typically found in double-ported constructions.

**Port-Guiding:** The valve plug is aligned by the valve body port. ■

### 3.7 Restricted-Capacity Control Valve Trim

Most control valve manufacturers can provide valves with reduced- or restricted-capacity trim parts. The reduced flow rate might be desirable for any of the following reasons:

- Restricted capacity trim may make it possible to select a valve body large enough for increased future flow requirements, but with trim capacity properly sized for present needs.
- Large bodies with restricted-capacity trim can be used to reduce inlet and outlet fluid velocities.
- Purchase of expensive pipeline reducers can be avoided.
- Over-sizing errors can be corrected by use of restricted-capacity trim parts.

Conventional globe-style valve bodies can be fitted with seat rings with smaller port sizes than normal and valve plugs sized to fit those smaller ports. Valves with cage-guided trim often achieve the reduced-capacity effect by using valve plug, cage, and seat ring parts from a smaller valve size of similar construction and adapter pieces above the cage and below the seat ring to mate those smaller parts with the valve body (Figure 3.36). Because reduced capacity service is not unusual, most manufacturers provide readily available trim part combinations to perform the required function. ■

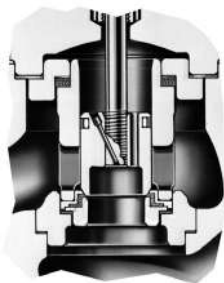

Figure 3.36 Adapter Method for Providing Reduced Flow Capacity

## 3.8 Actuators

Pneumatically-operated control valve actuators are the most popular type in use, but electric, hydraulic, and manual actuators are also widely used. The spring-and-diaphragm pneumatic actuator is most commonly specified due to its dependability and simplicity of design. Pneumatically-operated piston actuators provide high stem force output for demanding service conditions. Adaptations of both spring-and-diaphragm and pneumatic piston actuators are available for direct installation on rotary control valves.

### 3.8.1 Diaphragm Actuators

- Pneumatically-operated diaphragm actuators use air supply from controllers, positioners, or other sources.
- Various styles include: direct-acting, in which the increasing air pressure pushes the diaphragm down and extends the actuator stem (Figure 3.37); reverse-acting, in which the increasing air pressure pushes the diaphragm up and retracts the actuator stem (Figure 3.37); reversible, in which actuators can be assembled for either direct or reverse action (Figure 3.38); direct-acting unit for rotary valves, in which the increasing air pressure pushes down on the diaphragm, which, depending on orientation of the actuator lever on the valve shaft, may either open or close the valve (see Figure 3.39).
- Net output thrust is the difference between diaphragm force and opposing spring force.
- Molded diaphragms provide linear performance and increased travels.
- Output thrust required and supply

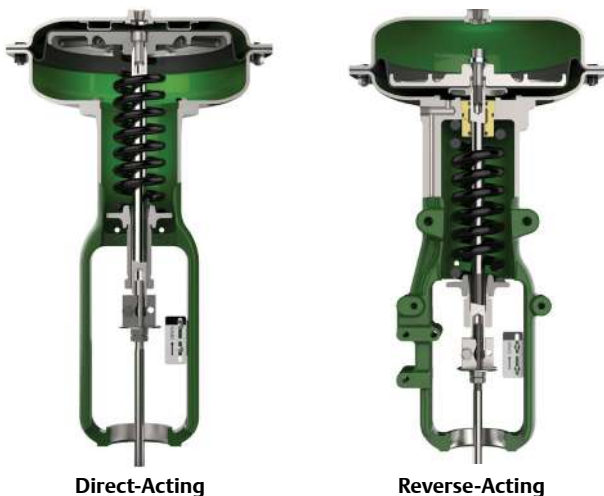

Figure 3.37 Diaphragm Actuators

air pressure available dictate size.

- Diaphragm actuators are simple, dependable, and economical.

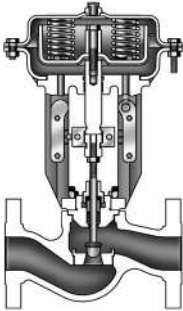

Figure 3.38 Field-Reversible Multi-Spring Actuator



Figure 3.39 Diaphragm Actuator for Rotary Valve

### 3.8.2 Piston Actuators

- Piston actuators are pneumatically-operated using high-pressure plant air up to 150 psig (10.3 bar), often eliminating the need for a supply pressure regulator.
- Piston actuators furnish maximum thrust output and fast stroking speeds.
- Piston actuators are double-acting to give maximum force in both directions, or spring-return to provide fail-open or fail-closed operation (Figure 3.40).
- Various accessories can be incorporated to position a double-acting piston in the event of supply pressure failure, including pneumatic trip valves and lock-up systems.

- Other versions for service on rotary control valves include a sliding seal in the lower end of the cylinder. This permits the actuator stem to move laterally, as well as up and down without leakage of cylinder pressure. This feature permits direct connection of the actuator stem to the actuator lever mounted on the rotary valve shaft, thus eliminating one joint or source of lost motion.



Figure 3.40 Control Valve with Double-Acting Piston Actuator



Figure 3.41 Control Valve with Scotch-Yoke Piston Actuator

### 3.8.3 Manual Actuators

- Manual actuators are useful where automatic control is not required, but where ease of operation and good manual control is still necessary (Figures 3.42 and 3.43). They are often used to actuate the bypass valve in a three-valve bypass loop around control valves for manual control of the process during maintenance or shut down of the automatic system.
- Manual actuators are available in various sizes for both globe-style and rotary valves.



- Dial-indicating devices are available for some models to permit accurate repositioning of the valve plug or disk.
- Manual actuators are much less expensive than automatic actuators.

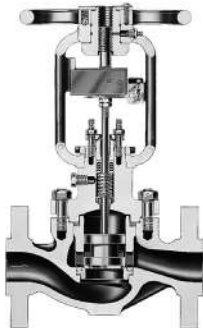

Figure 3.42 Manual Actuator for Sliding-Stem Valves



Figure 3.43 Manual Actuator for Rotary Valves

### 3.8.4 Rack-and-Pinion Actuators

Rack-and-pinion designs provide a compact and economical solution for rotary valves (Figure 3.44). Because of backlash, they are typically used for on/off applications or where process variability is not a concern.



Figure 3.44 Rack-and-Pinion Actuator

### 3.8.5 Electric Actuators

Electric actuator designs use an electric motor and some form of gear reduction to move the valve plug (Figures 3.45 and 3.46). While electric actuators have traditionally been limited to on/off operation, some are now capable of continuous control. The use of brushless motors in electric actuators can reduce or eliminate motor burnout associated with turning the motor on and off rapidly. The initial purchase price still tends to remain above that of pneumatic actuation. The primary usage of electric actuation is in areas where instrument air is not readily available or where an insufficient quantity of valves exist to justify the cost of a compressor system. ■



Figure 3.45 Electric Actuator for Sliding-Stem Valve



Figure 3.46 Electric Actuator for Rotary Valve

# Chapter 4

## Control Valve Accessories



Today, modern control systems use electronic signaling to command the control valve to open, close, or throttle. Additionally, these systems use position feedback signals and diagnostic information to validate the operation of the control valve. Furthermore, the performance expectations of control valves in terms of speed of response, accuracy, stability, reliability, and safety vary based on the process control needs. Because control valves are installed in many different and unique applications, control valve accessories are necessary. Accessories are the broad category of instruments that are directly connected to a control valve assembly.

There are five basic reasons that instrumentation and accessories are added to a control valve:

- Improve process control
- Improve safety for the process or personnel
- Improve valve performance or speed of response
- Monitor or verify the valve responsiveness
- Diagnose potential valve issues

## 4.1 Environmental & Application Considerations

Industrial plants, factories, mines, and mills experience tough environmental conditions due to their geographical location and the processes involved in manufacturing their products. As a result, valves and instruments in these facilities must be rugged and reliable.

Ambient temperatures for instrumentation can range from -60 to 125°C (-76 to 257°F). Corrosive atmospheres, such as salt water and chemical exposure, may require stainless steel or engineered resin materials of construction. Intense

vibration may require sturdy instrument mounting, rugged internal mechanisms, or remote mounting capability. High levels of humidity can lead to corrosion, so protection of electronic components may be necessary. Hazardous locations containing gaseous or dusty atmospheres may require instrumentation that is designed using protection concepts, such as flameproof, explosion proof, intrinsic safety, or non-incendive. These environmental and application conditions should be considered when selecting the proper control valve accessories. ■

## 4.2 Positioners

A common control valve accessory is the valve position controller, also called a positioner. The fundamental function of a positioner is to deliver pressurized air to the valve actuator, such that the position of the valve stem or shaft corresponds to the set point from the control system. Positioners are typically used when a valve requires throttling action. A positioner requires position feedback from the valve stem or shaft and delivers pneumatic pressure to the actuator to open and close the valve. The positioner must be mounted on or near the control valve assembly. There are three main categories of positioners, depending on the type of control signal, the diagnostic capability, and the communication protocol.

### 4.2.1 Pneumatic Positioners

The first category of positioners are pneumatic positioners. Legacy processing units may use pneumatic pressure signaling as the control set point to the control valves. Pressure is typically modulated between 20.7 to 103 kPa (3 to 15 psig) to move the valve from 0 to 100% position.

In a common pneumatic positioner

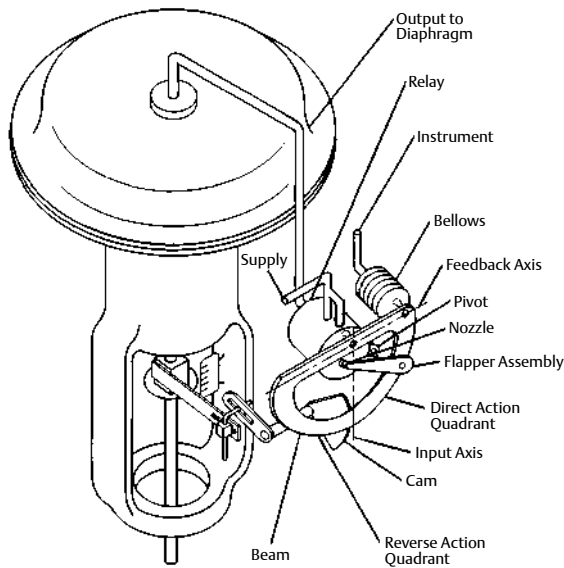

Figure 4.1 Typical Pneumatic, Single-Acting Positioner Design

design (Figure 4.1), the position of the valve stem or shaft is compared with the position of a bellows that receives the pneumatic control signal. When the input signal increases, the bellows expands and moves a beam. The beam pivots about an input axis, which moves a flapper closer to the nozzle. The nozzle pressure increases, which increases the output pressure to the actuator through a pneumatic amplifier relay. The increased output pressure to the actuator causes the valve stem to move. Stem movement is fed back to the beam by means of a cam. As the cam rotates, the beam pivots about the feedback axis to move the flapper slightly away from the nozzle. The nozzle pressure decreases and reduces the output pressure to the actuator. Stem movement continues, backing the flapper away from the nozzle until equilibrium is reached.

When the input signal decreases, the bellows contracts (aided by an internal range spring) and the beam pivots

about the input axis to move the flapper away from the nozzle. Nozzle pressure decreases and the relay permits the release of diaphragm casing pressure to the atmosphere, which allows the actuator stem to move upward. Through the cam, stem movement is fed back to the beam to reposition the flapper closer to the nozzle. When equilibrium conditions are obtained, stem movement stops and the flapper is positioned to prevent any further decrease in actuator pressure. See Figure 4.1.

#### 4.2.2 Analog I/P Positioners

The second type of positioner is an analog I/P positioner. Most modern processing units use a 4 to 20 mA DC signal to modulate the control valves. This introduces electronics into the positioner design and requires that the positioner convert the electronic current signal into a pneumatic pressure signal (current-to-pneumatic or I/P).

In a typical analog I/P positioner (see Figure 4.2), the converter receives a DC

input signal and provides a proportional pneumatic output signal through a nozzle/flapper arrangement. The pneumatic output signal provides the input signal to the pneumatic positioner. Otherwise, the design is the same as the pneumatic positioner.

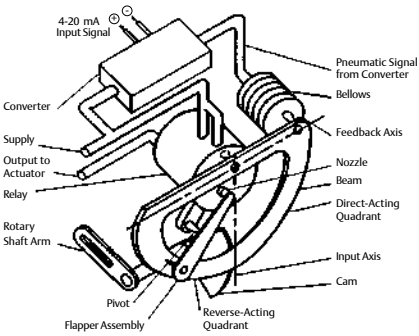

Figure 4.2 Typical Single-Acting Analog I/P Positioner Design

### 4.2.3 Digital Valve Controllers

While pneumatic positioners and analog I/P positioners provide basic valve position control, digital valve controllers add another dimension to positioner capabilities. This type of positioner is a microprocessor-based instrument. The microprocessor enables diagnostics and two-way communication to simplify setup and troubleshooting.

In a typical digital valve controller, the control signal is read by the microprocessor, processed by a digital algorithm, and converted into a drive current signal to the I/P converter. The microprocessor performs the position control algorithm rather than a mechanical beam, cam, and flapper assembly. As the control signal increases, the drive signal to the I/P converter increases, increasing the output pressure from the I/P converter. This pressure is routed to a pneumatic amplifier relay and provides two output pressures to the actuator. With

increasing control signal, one output pressure always increases and the other output pressure decreases.



Figure 4.3 Digital Valve Controller Mounted on a Control Valve

Double-acting actuators use both outputs, whereas single-acting actuators use only one output. The changing output pressure causes the actuator stem or shaft to move. Valve position is fed back to the microprocessor. The stem continues to move until the correct position is attained. At this point, the microprocessor stabilizes the drive signal to the I/P converter until equilibrium is obtained.

In addition to the function of controlling the position of the valve, a digital valve controller has two additional capabilities: diagnostics and two-way digital communication.

#### 4.2.3.1 Diagnostics

The microprocessor inside the digital valve controller allows the positioner to run, analyze, and store diagnostic tests.

Diagnostic information is useful in determining the health of the entire control valve assembly. Through the

use of pressure sensors, temperature sensors, travel sensors, and internal readings, graphical representations of control valve performance and health are created and recommended actions are presented. This information is then used to identify elements of the control valve assembly that may require maintenance.

#### 4.2.3.2 Two-Way Digital Communication

The microprocessor inside the digital valve controller also allows the positioner to communicate with the control system via a digital signal. This enables the digital valve controller to provide additional feedback, such as actual valve travel and diagnostic alerts back to the control system.

One widely used protocol is HART® communication. HART communication uses a digital signal superimposed over the traditional 4 to 20 mA DC control signal. This communication protocol allows the host system to be used to configure, calibrate, and monitor the health of the positioner. HART communication offers the benefits of digital communication with the familiarity of a 4 to 20 mA control system.

FOUNDATION™ fieldbus is another industry standard protocol. This protocol is all digital, which means that the control signal (set point) is digital, rather than a 4 to 20 mA DC current. Similar to HART communication, the host system can also be used to configure, calibrate, and monitor the positioner.

PROFIBUS is also a common industry protocol that provides all digital communication. The physical layer for PROFIBUS and FOUNDATION fieldbus is the same; however, the communication protocols differ and offer their own advantages.

Wireless technology offers an additional method to communicate

information between the control system and the digital valve controller. For positioners outfitted with wireless capability, digital information can be transmitted independent of the control system wiring. ■

## 4.3 I/P Transducers

In some applications, the high level of positioning accuracy that a positioner provides is not required. In these applications, an electro-pneumatic (I/P) transducer can be used. An I/P transducer (Figure 4.4) uses a converter module that converts a 4 to 20 mA current input to a proportional pressure output. An internal pneumatic amplifier relay provides the capacity necessary to deliver output pressure to the control valve actuator. There is no valve position feedback and responsiveness is very quick. ■



Figure 4.4 Transducer Mounted on a Control Valve

## 4.4 Volume Boosters

Positioners and I/P transducers are designed to provide enough pneumatic output capacity to drive a typical throttling control valve. However, some

applications require faster stroking speeds. When the actuator volume is large, the positioning speed of response can become more of a concern.

Volume boosters are used to provide additional pneumatic output capacity to a valve assembly (Figure 4.5). A large, sudden change in input signal (output pressure from the positioner) causes a pressure differential to exist

between the input signal and the output of the booster. When this occurs, the diaphragms move to open the supply port or the exhaust port, whichever action is required to reduce the differential. The port remains open until the difference between the booster input and output pressure is within the deadband limit of the booster.

With the bypass restriction adjusted

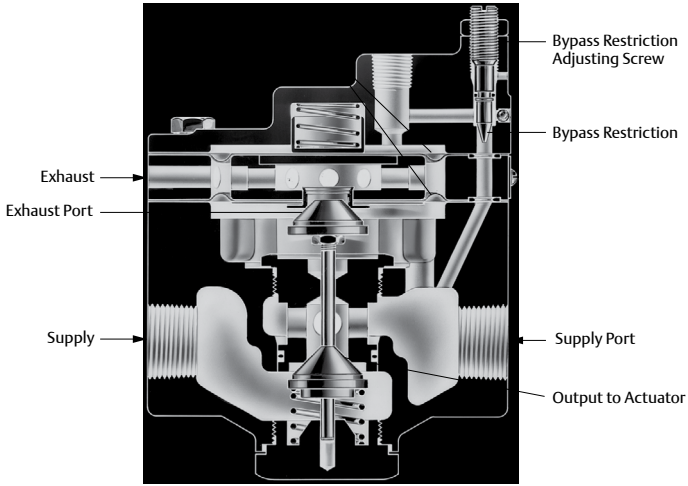

Figure 4.5 Volume Booster Sectional View

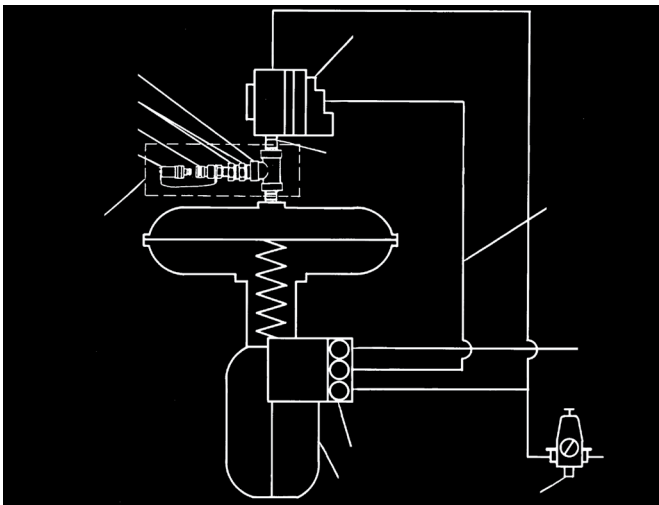

Figure 4.6 Typical Booster Installation with a Single-Acting Actuator



for stable operation, signals having small magnitude and rate changes pass through the bypass restriction and into the actuator without initiating booster operation. Both the supply and exhaust ports remain closed, preventing unnecessary air consumption and possible saturation of positioner relays.

Single-acting actuators typically use one volume booster (Figure 4.6). Double-acting actuators require at least two volume boosters, one to feed each side of the actuator piston. Some applications, such as compressor anti-surge or turbine bypass, may require additional volume boosters to provide the needed pneumatic volume for fast valve response. ■

## 4.5 Safety Instrumented Systems (SIS)

The primary purpose of a control valve is to modulate the flow of liquid or gas in a pipe within a process control loop. Within these same process loops, there are also emergency vent, block, or isolation valves. These valves are

typically on/off valves that are used to take the process loop to a safe state in the event of a process control emergency (Figure 4.7). A separate safety system, often controlled by a logic solver, controls these valves.

### 4.5.1 Partial Stroke Testing

Because safety valves are static and do not modulate under normal conditions, they are prone to sticking. When an emergency demand occurs, there is a risk that the valves will not move when commanded. To mitigate this risk, the digital valve controller can be used as a partial stroke testing device.

An important function of the instrument is periodically exercising the valve. This is performed with a valve partial stroke test (PST). The PST slowly moves the valve a portion of the total valve travel and then returns to the normal state. This exercises the mechanical components of the safety valve with minimal disruption to the process loop. Furthermore, the digital valve controller has the ability to diagnose potential issues and communicate any alerts if the test fails.



Figure 4.7 SIS Digital Valve Controller on a Safety Valve



### 4.5.2 Safety Function and Product Certification

A spring-return, single-acting actuator provides an inherent fail mode for the valve assembly. During an emergency demand, the typical method to move the valve to the safe state is to remove the air pressure to the actuator and allow the spring to position the valve. A solenoid valve and/or digital valve controller can be used to perform this function. There may be additional instrumentation on the safety valve, such as boosters, position transmitters, and trip systems. All of these elements must be evaluated for their effect on the safety system.

These elements can fail by causing an unplanned trip or by not getting the safety valve to the safe state. The Failure Modes, Effects, and Diagnostics Analysis (FMEDA) provides metrics for each component. This allows a safety engineer to design the safety instrumented system to the desired level of risk reduction. See Chapter 12 for more information about safety instrumented systems. ■

## 4.6 Controllers

In some applications, control of the process is performed locally without the need for a large scale distributed control system (DCS) or programmable logic controller (PLC). Local controllers are used to measure process conditions, such as pressure, temperature, or level and directly drive the pneumatic output pressure to a control valve (Figure 4.8).

The input to the local controller is typically pressure, differential pressure, temperature, or level displacement. The process measurement is translated into a beam-flapper assembly movement, which is connected to an input element. The input element can be a Bourdon tube, bellows assembly,

liquid displacement lever assembly, or temperature bulb.



Figure 4.8 Pneumatic Controller on a Control Valve

The input element is connected to the process pointer (set point adjustment) and to the flapper by connecting links. As the process input increases (in a direct-acting controller), the flapper moves toward the nozzle, which restricts flow through the nozzle and increases nozzle pressure. When this occurs, relay action increases the output pressure to the actuator, which modulates the control valve. Output pressure is fed back to the proportional bellows. The action of the proportional bellows counters the flapper movement that resulted from the process input change. It then moves the flapper away from the nozzle until the controller reaches a point of equilibrium. The set point adjustment changes the proximity of the nozzle and flapper, as does a change in process input. However, when the set point is changed, the nozzle moves with respect to the flapper.

The proportional band adjustment knob positions the nozzle on the flapper. Increasing or widening the proportional band moves the nozzle to a position on the flapper where less flapper motion occurs, decreasing the gain of the controller. Decreasing or narrowing the proportional band moves the nozzle toward a position where more flapper motion occurs, increasing the gain. Controller action is changed from direct to reverse by turning the proportional band adjustment knob to position the nozzle to a point on the flapper where the direction of the flapper motion versus the input motion is reversed. With the controller in the reverse-acting mode, an increase in process input causes a decrease in output pressure to the actuator. Supply pressure bleeds through a fixed orifice in the relay and exits through the nozzle. The nozzle pressure registers on the large relay diaphragm and modulates loading pressure on the small relay diaphragm. This also modulates the controller output pressure to the actuator (Figure 4.9).

Controllers with proportional-plus-reset operation are similar to that of proportional-only controllers, except that output pressure is fed back to the reset

and proportional bellows. In operation, proportional-plus-reset controllers minimize the offset between the process variable and the set point.

Controllers with proportional-plus-reset-plus-rate have a rate valve, an adjustable restriction that briefly maintains the controller gain to accelerate the corrective action for slow systems (Figure 4.10). The rate action delays the gain reduction just long enough to allow the system to respond to the change, but not long enough for the system to become unstable. Then, the low gain provided by the proportional action keeps the system stable. Finally, the reset action slowly increases the gain and returns the process toward the set point.

Anti-reset windup reduces overshoot of the process input that can result from large or prolonged deviation from the set point. This option can be adjusted to operate on either increasing or decreasing output pressure. The differential relief valve operates when the difference between proportional bellows pressure and reset bellows pressure reaches a predetermined value. ■

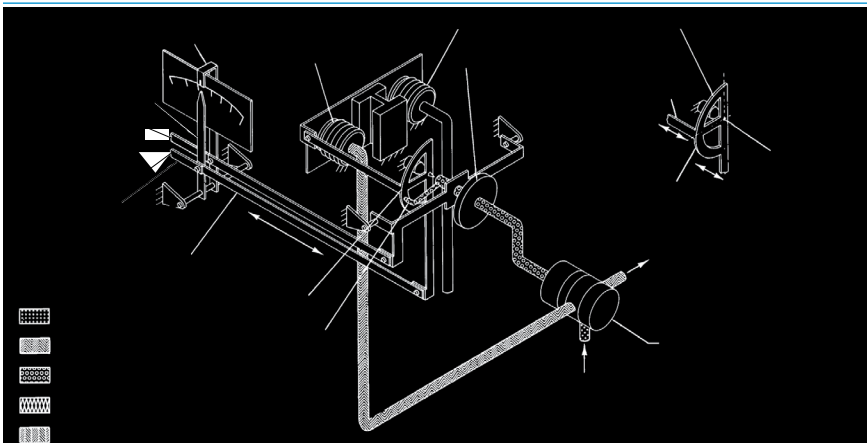

Figure 4.9 Pneumatic Controller Schematic

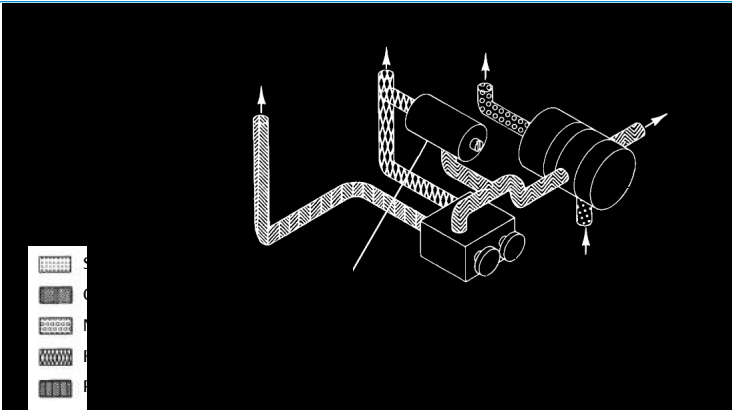

Figure 4.10 Pneumatic Controller Schematic

## 4.7 Position Transmitters

The purpose of a position transmitter is to provide independent valve position feedback to the control system. Position feedback is often used for process monitoring, troubleshooting, or startup/shutdown verification. The position transmitter is mounted directly to the valve and measures the position of the valve stem or shaft. In a wired installation, the position transmitter provides a 4 to 20 mA signal that corresponds with the throttling range of the control valve. In a wireless installation, the position transmitter provides a 0 to 100% digital signal (Figure 4.11). ■



Figure 4.11 Wireless Position Monitor Mounted on an Actuator

## 4.8 Limit Switches

The purpose of a limit switch is to provide a discrete open or close signal to the control system when the valve reaches a specific position within its range of travel. Limit switches are also used for process monitoring, troubleshooting, or startup/shutdown verification. The limit switch receives position feedback from the valve stem or shaft and will send either a wired or a wireless signal to the control system. There are many different switch technologies available, such as proximity, solid state, magnetic, and contact closure. ■

## 4.9 Solenoid Valves

A solenoid valve is installed in the pneumatic tubing path to the actuator. In some applications, the solenoid valve will vent the air from the actuator to allow the valve to move to its no air, fail state. In other applications, the solenoid valve will trap air in the actuator to lock the valve in its current position. Three-way solenoids are generally used to operate spring-return actuators and four-way solenoids are generally used for double-acting actuators. The solenoid valve is activated by making or breaking

a discrete electrical signal from the control system. See Chapter 11 for more information about solenoid valves. ■

## 4.10 Trip Systems

Trip systems are used in control applications where a specific actuator action is required in the event that supply pressure is lost (Figure 4.12). These are used with double-acting actuators that do not have an inherent no air, fail state or with single- or double-acting actuators to provide pneumatic lock-up.

When supply pressure falls below the trip point, the trip valve causes the actuator to fail up, lock in the last position, or fail down. For double-acting applications, a volume tank provides the reserve pneumatic air capacity to operate the valve until the supply pressure is restored. When the supply pressure rises above the trip point, the trip valve automatically resets, allowing the

system to return to normal operation. ■

## 4.11 Handwheels

Handwheels for diaphragm actuators are often used as adjustable travel stops. They also provide a ready means of positioning the control valve in an emergency.

Side-mounted handwheels can be used to stroke the valve in either direction at any point in the actuator stem travel (Figure 4.13). The side-mounted handwheel can be positioned to limit travel in either direction, but not both at the same time. With the handwheel in the neutral position, automatic operation is possible throughout full valve travel. In any other position, valve travel will be restricted.

Top-mounted handwheels are used for infrequent service to manually stroke the valve (Figure 4.14). ■

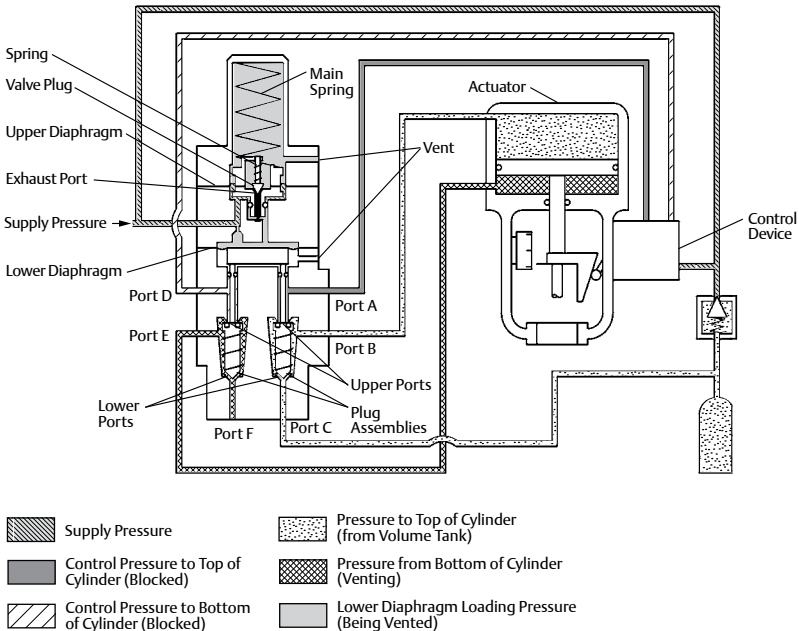

Figure 4.12 Trip Valve Shown in Tripped Condition



Figure 4.13 Actuator with Side-Mounted Handwheel



Figure 4.14 Actuator with Top-Mounted Handwheel

# Chapter 5

## Control Valve Sizing



Control valves handle all kinds of fluids at temperatures from the cryogenic range to well over 538°C (1000°F). Selection of a control valve body assembly requires particular consideration to provide the best available combination of valve body style, material, and trim construction design for the intended service. Capacity requirements and system operating pressure ranges also must be considered in selecting a control valve to ensure satisfactory operation without undue initial expense.

Reputable control valve manufacturers and their representatives are dedicated to helping select the control valve most appropriate for the existing service conditions. Because there are frequently several possible correct choices for an application, it is important that all the following information be provided for any set of conditions deemed important:

- Type of fluid to be controlled
- Temperature of fluid
- Viscosity of fluid
- Concentrations of all constituents including trace impurities
- Process conditions during startup, normal operations, and shutdowns
- Chemical cleaning that may occur periodically
- Specific gravity or density of fluid
- Fluid flow rate
- Inlet pressure at valve
- Outlet pressure or pressure drop
- Pressure drop at shutoff
- Maximum permissible noise level, if pertinent, and the measurement reference point
- Degrees of superheat or existence of flashing, if known
- Inlet and outlet pipeline size and schedule
- Special tagging information required
- Cast body material (ASTM A216 grade WCC, ASTM A217 grade WC9, ASTM A351 CF8M, etc.)
- End connections and valve rating (screwed, Class 600 RF flanged, Class 1500 RTJ flanges, etc.)
- Action desired on air failure (valve to open, close, or retain last controlled position)
- Instrument air supply available
- Instrument signal (3 to 15 psig, 4 to 20 mA, HART, etc.)

In addition, the following information will require the agreement of the user and the manufacturer depending on the purchasing and engineering practices being followed.

- Valve type number
- Valve size
- Valve body construction (angle, double-port, butterfly, etc.)
- Valve plug guiding (cage-style, port-guided, etc.)
- Valve plug action (push-down-to-close or push-down-to-open)
- Port size (full or restricted)
- Valve trim materials required
- Flow action (flow tends to open valve or flow tends to close valve)
- Actuator size required
- Bonnet style (plain, extension, bellows seal, etc.)
- Packing material (PTFE V-ring, laminated graphite, environmental sealing systems, etc.)
- Accessories required (positioner, handwheel, etc.)

Some of these options have been discussed in previous chapters of this book, and others will be explored in this and following chapters.



## Valve Selection Process

### 1. Determine Service Conditions

P1,  $\Delta P$ , Q, T1, fluid properties, allowable noise, etc.  
Select appropriate ANSI pressure class required for valve body and trim.

### 2. Calculate Preliminary $C_v$ Required

Check noise and cavitation levels.

### 3. Select Trim Type

If no noise or cavitation indication, choose standard trim.  
If aerodynamic noise is high, choose a noise reduction trim.  
If liquid noise is high and/or cavitation is indicated, choose a cavitation reduction trim.

### 4. Select Valve Body and Trim Type

Select valve body and trim size with required  $C_v$ .  
Note travel, trim group, and shutoff options.

### 5. Select Trim Materials

Select trim materials for your application.  
Make sure trim selected is available in the trim group for the valve size selected.

### 6. Consider Options

Consider options on shutoff, stem packing, etc.

## 5.1 Control Valve Dimensions

### 5.1.1 Face-to-Face Dimensions for Flanged, Globe-Style Control Valves

Classes 125, 150, 250, 300, and 600 (Dimensions in Accordance with ANSI/ISA-75.08.01)

Valve Size		Pressure Ratings and End Connections					
		Class 125 FF (CI) Class 150 RF (STL)		Class 150 RTJ (STL)		Class 250 RF (CI) Class 300 RF (STL)	
DN	NPS	mm	in	mm	in	mm	in
15	1/2	184	7.25	197	7.75	190	7.50
20	3/4	184	7.25	197	7.75	194	7.62
25	1	184	7.25	197	7.75	197	7.75
40	1-1/2	222	8.75	235	9.25	235	9.25
50	2	254	10.00	267	10.50	267	10.50
65	2-1/2	276	10.88	289	11.38	292	11.50
80	3	298	11.75	311	12.25	318	12.50
100	4	352	13.88	365	14.38	368	14.50
150	6	451	17.75	464	18.25	473	18.62
200	8	543	21.38	556	21.88	568	22.38
250	10	673	26.50	686	27.00	708	27.88
300	12	737	29.00	749	29.50	775	30.50
350	14	889	35.00	902	35.50	927	36.50
400	16	1016	40.00	1029	40.50	1057	41.62

Abbreviations used above: FF - Flat Face; RF - Raised Face; RTJ - Ring-Type Joint; CI - Cast Iron



## Face-to-Face Dimensions for Flanged, Globe-Style Valves continued...

Valve Size		Pressure Ratings and End Connections					
		Class 300 RTJ (STL)		Class 600 RF (STL)		Class 600 RTJ (STL)	
DN	NPS	mm	in	mm	in	mm	in
15	1/2	202	7.94	203	8.00	203	8.00
20	3/4	206	8.12	206	8.12	206	8.12
25	1	210	8.25	210	8.25	210	8.25
40	1-1/2	248	9.75	251	9.88	251	9.88
50	2	282	11.12	286	11.25	284	11.37
65	2-1/2	308	12.12	311	12.25	314	12.37
80	3	333	13.12	337	13.25	340	13.37
100	4	384	15.12	394	15.50	397	15.62
150	6	489	19.24	508	20.00	511	20.12
200	8	584	23.00	610	24.00	613	24.12
250	10	724	28.50	752	29.62	755	29.74
300	12	790	31.12	819	32.25	822	32.37
350	14	943	37.12	972	38.25	475	38.37
400	16	1073	42.24	1108	43.62	1111	43.74

Abbreviations used above: STL - Steel

## Classes 900, 1500, and 2500 (Dimensions in Accordance with ANSI/ISA-75.08.06)

Valve Size		Class 900				Class 1500	
		mm		in		mm	
DN	NPS	Short	Long	Short	Long	Short	Long
15	1/2	273	292	10.75	11.50	273	292
20	3/4	273	292	10.75	11.50	273	292
25	1	273	292	10.75	11.50	273	292
40	1-1/2	311	333	12.25	13.12	311	333
50	2	340	375	13.38	14.75	340	375
65	2-1/2	---	410	---	16.12	---	410
80	3	387	441	15.25	17.38	406	460
100	4	464	511	18.25	20.12	483	530
150	6	600	714	21.87	28.12	692	768
200	8	781	914	30.75	36.00	838	972
250	10	864	991	34.00	39.00	991	1067
300	12	1016	1130	40.00	44.50	1130	1219
350	14	---	1257	---	49.50	---	1257
400	16	---	1422	---	56.00	---	1422
450	18	---	1727	---	68.00	---	1727

*Face-to-Face Dimensions for Flanged, Globe-Style Valves continued...*

Valve Size		Class 1500		Class 2500			
		in		mm		in	
DN	NPS	Short	Long	Short	Long	Short	Long
15	1/2	10.75	11.50	308	318	12.12	12.50
20	3/4	10.75	11.50	308	318	12.12	12.50
25	1	10.75	11.50	308	318	12.12	12.50
40	1-1/2	12.25	13.12	359	381	14.12	15.00
50	2	13.38	14.75	---	400	---	16.25
65	2-1/2	---	16.12	---	441	---	17.38
80	3	16.00	18.12	498	660	19.62	26.00
100	4	19.00	20.87	575	737	22.62	29.00
150	6	24.00	30.25	819	864	32.25	34.00
200	8	33.00	38.25	---	1022	---	40.25
250	10	39.00	42.00	1270	1372	50.00	54.00
300	12	44.50	48.00	1321	1575	52.00	62.00
350	14	---	49.50	---	---	---	---
400	16	---	56.00	---	---	---	---
450	18	---	68.00	---	---	---	---

**5.1.2 Face-to-Face Dimensions for Butt Weld-End, Globe-Style Valves**

Classes 150, 300, 600, 900, 1500, and 2500 (Dimensions in Accordance with ANSI/ISA-75.08.05)

Valve Size		Class 150, 300, and 600				Class 900 and 1500	
		mm		in		mm	
DN	NPS	Short	Long	Short	Long	Short	Long
15	1/2	187	203	7.38	8.00	194	279
20	3/4	187	206	7.38	8.25	194	279
25	1	187	210	7.38	8.25	197	279
40	1-1/2	222	251	8.75	9.88	235	330
50	2	254	286	10.00	11.25	292	375
65	2-1/2	292	311	11.50	12.25	292	375
80	3	318	337	12.50	13.25	318	460
100	4	368	394	14.50	15.50	368	530
150	6	451	508	17.75	20.00	508	768
200	8	543	610	21.38	24.00	610	832
250	10	673	752	26.50	29.62	762	991
300	12	737	819	29.00	32.35	914	1130
350	14	851	1029	33.50	40.50	---	1257
400	16	1016	1108	40.00	43.62	---	1422
450	18	1143	---	45.00	---	---	1727

*Face-to-Face Dimensions for Butt Weld-End, Globe-Style Valves continued...*

Valve Size		Class 900 and 1500		Class 2500			
		in		mm		in	
DN	NPS	Short	Long	Short	Long	Short	Long
15	1/2	7.62	11.00	216	318	8.50	12.50
20	3/4	7.62	11.00	216	318	8.50	12.50
25	1	7.75	11.00	216	318	8.50	12.50
40	1-1/2	9.25	13.00	260	359	10.25	14.12
50	2	11.50	14.75	318	400	12.50	15.75
65	2-1/2	11.50	14.75	318	400	12.50	15.75
80	3	12.50	18.12	381	498	15.00	19.62
100	4	14.50	20.88	406	575	16.00	22.62
150	6	24.00	30.25	610	819	24.00	32.25
200	8	24.00	32.75	762	1029	30.00	40.25
250	10	30.00	39.00	1016	1270	40.00	50.00
300	12	36.00	44.50	1118	1422	44.00	56.00
350	14	---	49.50	---	1803	---	71.00
400	16	---	56.00	---	---	---	---
450	18	---	68.00	---	---	---	---

**5.1.3 Face-to-Face Dimensions for Socket Weld-End, Globe-Style Valves**

Classes 150, 300, 600, 900, 1500, and 2500 (Dimensions in Accordance with ANSI/ISA-75.08.03)

Valve Size		Class 150, 300, and 600				Class 900 and 1500	
		mm		in		mm	
DN	NPS	Short	Long	Short	Long	Short	Long
15	1/2	170	206	6.69	8.12	178	279
20	3/4	170	210	6.69	8.25	178	279
25	1	197	210	7.75	8.25	178	279
40	1-1/2	235	251	9.25	9.88	235	330
50	2	267	286	10.50	11.25	292	375
65	2-1/2	292	311	11.50	12.25	292	---
80	3	318	337	12.50	13.25	318	533
100	4	368	394	14.50	15.50	368	530

*Face-to-Face Dimensions for Socket Weld-End, Globe-Style Valves continued...*

Valve Size		Class 900 and 1500		Class 2500			
		in		mm		in	
DN	NPS	Short	Long	Short	Long	Short	Long
15	1/2	7.00	11.00	216	318	8.50	12.50
20	3/4	7.00	11.00	216	318	8.50	12.50
25	1	7.00	11.00	216	318	8.50	12.50
40	1-1/2	9.25	13.00	260	381	10.25	15.00
50	2	11.50	14.75	324	400	12.75	15.75
65	2-1/2	11.50	---	324	---	12.75	---
80	3	12.50	21.00	381	660	15.00	26.00
100	4	14.50	20.88	406	737	16.00	29.00

**5.1.4 Face-to-Face Dimensions for Screwed-End, Globe-Style Valves**

Classes 150, 300, and 600 (Dimensions in Accordance with ANSI/ISA-75.08.03)

Valve Size		Class 150, 300, and 600			
		mm		in	
DN	NPS	Short	Long	Short	Long
15	1/2	165	206	6.50	8.12
20	3/4	165	210	6.50	8.25
25	1	197	210	7.75	8.25
40	1-1/2	235	251	9.25	9.88
50	2	267	286	10.50	11.25
65	2-1/2	292	311	11.50	12.26

**5.1.5 Face-to-Centerline Dimensions for Raised-Face, Globe-Style Angle Valves**

Classes 150, 300, and 600 (Dimensions in Accordance with ANSI/ISA-75.08.08)

Valve Size		Class 150		Class 300		Class 600	
		mm	in	mm	in	mm	in
DN	NPS	mm	in	mm	in	mm	in
25	1	92	3.62	99	3.88	105	4.12
40	1-1/2	111	4.37	117	4.62	125	4.94
50	2	127	5.00	133	5.25	143	5.62
80	3	149	5.88	159	6.25	168	6.62
100	4	176	6.94	184	7.25	197	7.75
150	6	226	8.88	236	9.31	254	10.00
200	8	272	10.69	284	11.19	305	12.00

### 5.1.6 Face-to-Face Dimensions for Separable Flange, Globe-Style Valves

Classes 150, 300, and 600 (Dimensions in Accordance with ANSI/ISA-75.08.07)

Valve Size		Class 150, 300, and 600	
DN	NPS	mm	in
25	1	216	8.50
40	1-1/2	241	9.50
50	2	292	11.50
80	3	356	14.00
100	4	432	17.00

### 5.1.7 Face-to-Face Dimensions for Flanged and Flangeless Rotary Valves (Except Butterfly)

Classes 150, 300, and 600 (Dimensions in Accordance with ANSI/ISA-75.08.02)

Valve Size		Classes 150, 300 and 600	
DN	NPS	mm	in
20	3/4	76	3.00
25	1	102	4.00
40	1-1/2	114	4.50
50	2	124	4.88
80	3	165	6.50
100	4	194	7.62
150	6	229	9.00
200	8	243	9.56
250	10	297	11.69
300	12	338	13.31
350	14	400	15.75
400	16	400	15.75
450	18	457	18.00
500	20	508	20.00
600	24	610	24.00

### 5.1.8 Face-to-Face Dimensions for Single Flange (Lug-Type) and Flangeless (Wafer-Type) Butterfly Valves

(Dimensions in Accordance with MSS-SP-67)

Valve Size		Dimensions for Narrow Valve Body, Installed <sup>(1)(2)</sup>	
DN	NPS	in	mm
40	1-1/2	1.31	33.3
50	2	1.69	42.9
65	2-1/2	1.81	46.0
80	3	1.81	46.0
100	4	2.06	52.3
150	6	2.19	55.6
200	8	2.38	60.5
250	10	2.69	68.3
300	12	3.06	77.7
350	14	3.06	77.7
400	16	3.12	79.2
450	18	4.00	101.6
500	20	4.38	111.2

1. Bodies compatible with Class 125 cast iron flanges or Class 150 steel flanges.  
 2. This is the dimension of the valve face-to-face after it is installed in the pipeline. It does not include the thickness of gaskets if separate gaskets are used. It does include the thickness of gaskets or seals that are an integral part of the valve; however, this dimension is established with the gaskets or seals compressed.

### 5.1.9 Face-to-Face Dimensions for High-Pressure Butterfly Valves with Offset Design

Classes 150, 300, and 600 (Dimensions in Accordance with MSS SP-68)

Valve Size		Class 150		Class 300		Class 600	
DN	NPS	in	mm	in	mm	in	mm
80	3	1.88	48	1.88	48	2.12	54
100	4	2.12	54	2.12	54	2.50	64
150	6	2.25	57	2.31	59	3.06	78
200	8	2.50	63	2.88	73	4.00	102
250	10	2.81	71	3.25	83	4.62	117
300	12	3.19	81	3.62	92	5.50	140
350	14	3.62	92	4.62	117	6.12	155
400	16	4.00	101	5.25	133	7.00	178
450	18	4.50	114	5.88	149	7.88	200
500	20	5.00	127	6.25	159	8.50	216
600	24	6.06	154	7.12	181	9.13	232

## 5.2 Control Valve Seat Leakage Classifications

(In Accordance with ANSI/FCI 70-2 and IEC 60534-4)

Leakage Class Designation	Maximum Leakage Allowable	Test Medium	Test Pressures	Testing Procedures Required for Establishing Rating
I	---	---	---	No test required provided user and supplier so agree.
II	0.5% of rated capacity	Air or water at 10-52°C (50-125°F)	3-4 bar (45-60 psig) or max. operating differential, whichever is lower.	Pressure applied to valve inlet, with outlet open to atmosphere or connected to a low head loss measuring device, full normal closing thrust provided by actuator.
III	0.1% of rated capacity	As above	As above	As above
IV	0.01% of rated capacity	As above	As above	As above
V	0.0005ml per minute of water per inch of orifice diameter per psi differential ( $5 \times 10^{-12} \text{m}^3$ per second of water per mm of orifice diameter per bar differential).	Water at 10-52°C (50-125°F)	Max. service pressure drop across valve plug, not to exceed ANSI body rating, or lesser pressure by agreement.	Pressure applied to valve inlet after filling entire body cavity and connected piping with water and stroking valve plug closed. Use net specified max. actuator thrust, but no more, even if available during test. Allow time for leakage flow to stabilize.
VI	Not to exceed amounts shown in following table based on port diameter.	Air or nitrogen at 10-52°C (50-125°F)	3.5 bar (50 psig) or max. rated differential pressure across valve plug, whichever is lower.	Pressure applied to valve inlet. Actuator should be adjusted to operating conditions specified with full normal closing thrust applied to valve plug seat. Allow time for leakage flow to stabilize and use suitable measuring device.

## 5.3 Class VI Maximum Seat Leakage Allowable

(In Accordance with ANSI/FCI 70-2)

Nominal Port Diameter		Bubbles per Minute <sup>(1)</sup>	
in	mm	ml per Minute	Bubbles per Minute
1	25	0.15	1
1-1/2	38	0.30	2
2	51	0.45	3
2-1/2	64	0.60	4
3	76	0.90	6
4	102	1.70	11
6	152	4.00	27
8	203	6.75	45

1. Bubbles per minute as tabulated are a suggested alternative based on a suitably calibrated measuring device, in this case a 1/4 inch (6.3 mm) O.D. x 0.032 inch (0.8 mm) wall tube submerged in water to a depth of from 1/8 to 1/4 inch (3 to 6 mm). The tube end shall be cut square and smooth with no chamfers or burrs, and the tube axis shall be perpendicular to the surface of the water. Other apparatus may be constructed and the number of bubbles per minute may differ from those shown as long as they correctly indicate the flow in ml per minute.

## 5.4 Control Valve Flow Characteristics

The flow characteristic of a control valve is the relationship between the flow rate through the valve and the valve travel as the travel is varied from 0 to 100%. Inherent flow characteristic refers to the characteristic observed with a constant pressure drop across the valve. Installed flow characteristic means the one obtained in service where the pressure drop varies with flow and other changes in the system.

Characterizing control valves provides for a relatively uniform control loop stability over the expected range of system operating conditions. To establish the flow characteristic needed to match a given system requires a dynamic analysis of the control loop. Analyses of the more common processes have been performed, however, so some useful guidelines for the selection of the proper flow characteristic can be established. Those guidelines will be discussed after a brief look at the flow characteristics in use today.

### 5.4.1 Flow Characteristics

Figure 5.1 illustrates typical flow characteristic curves. The quick-opening flow characteristic provides for maximum change in flow rate at low valve travels with a nearly linear relationship. Additional increases in valve travel give sharply reduced changes in flow rate, and when the valve plug nears the wide open position, the change in flow rate approaches zero. In a control valve, the quick-opening valve plug is used primarily for on/off service; but it is also suitable for many applications where a linear valve plug would normally be specified.

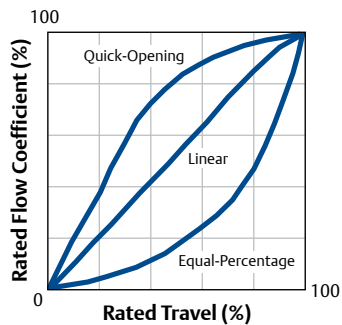

Figure 5.1 Feedback Control Loop



The linear flow characteristic curve shows that the flow rate is directly proportional to the valve travel. This proportional relationship produces a characteristic with a constant slope so that with constant pressure drop, the valve gain will be the same at all flows. (Valve gain is the ratio of an incremental change in valve plug position. Gain is a function of valve size and configuration, system operating conditions and valve plug characteristic.) The linear valve plug is commonly specified for liquid level control and for certain flow control applications requiring constant gain.

In the equal-percentage flow characteristic, equal increments of valve travel produce equal-percentage changes in the existing flow. The change in flow rate is always proportional to the flow rate just before the change in valve plug, disk, or ball position is made. When the valve plug, disk, or ball is near its seat, the flow is small; with a large flow, the change in flow rate will be large. Valves with an equal-percentage flow characteristic are generally used on pressure control applications and on other applications where a large percentage of the pressure drop is normally absorbed by the system itself, with only a relatively small percentage available at the control valve. Valves with an equal-percentage characteristic should also be considered where highly varying pressure drop conditions can be expected.

#### **5.4.2 Selection of Flow Characteristics**

The ideal flow characteristic would be one that would result in a linear installed characteristic and a uniform installed gain. For optimal performance, a complete dynamic analysis could be performed, since there are many other factors besides flow characteristic that affect performance. Such an analysis would be most appropriate for

applications where accurate control is critical. For other applications, a less-than-ideal flow characteristic may be adjusted to some degree in the control equipment. See Chapter 2 for more information on control valve performance. ■

### **5.5 Valve Sizing**

Standardization activities for control valve sizing can be traced back to the early 1960s when a trade association, the Fluids Control Institute, published sizing equations for use with both compressible and incompressible fluids. The range of service conditions that could be accommodated accurately by these equations was quite narrow, and the standard did not achieve a high degree of acceptance. In 1967, the ISA established a committee to develop and publish standard equations. The efforts of this committee culminated in a valve sizing procedure that has achieved the status of American National Standard. Later, a committee of the International Electrotechnical Commission (IEC) used the ISA works as a basis to formulate international standards for sizing control valves. (Some information in this introductory material has been extracted from ANSI/ISA-75.01.01 standard with the permission of the publisher, the ISA.) The ANSI/ISA-75.01.01 and IEC 60534-2-1 valve sizing standards have been harmonized, so either standard may be used.

Although the standard valve sizing methods work well for the majority of control valve sizing situations, it is important to note that the standards call out limits for their use. Use outside of their intended boundaries must be done with care. The standards' requirements for reasonable accuracy are:

- Single component, single phase fluids
- Newtonian fluids

- Ideal gases and vapors
- Ideal ratio of specific heats in the range  $1.08 < \gamma < 1.65$  for gases and vapors
- Valves with  $x_T \leq 0.84$
- Valves with  $C_v/d^2 < 30$

In the following sections, the nomenclature and procedures are explained, and sample problems are solved to illustrate their use. For the discussion below, all flows are assumed to be fully turbulent. For situations with high viscosity fluids or very low flow rates, additional considerations are required. ■

## 5.6 Abbreviations and Terminology

Symbol		Symbol	
$C_v$	Valve sizing coefficient	$\Delta P$	Pressure drop ( $P_1 - P_2$ ) across the valve
$d$	Nominal valve size	$\Delta P_{\text{choked}}$	Liquid pressure drop that limits the flow by choking
$D_1, D_2$	Internal diameter of the upstream and downstream piping, respectively	$\Delta P_{\text{sizing}}$	Pressure drop value used for liquid sizing calculations
$F_d$	Valve style modifier, dimensionless	$q$	Standard volumetric flow rate <sup>(1)</sup>
$F_F$	Liquid critical pressure ratio factor, dimensionless	$T_1$	Absolute upstream temperature
$F_\gamma$	Ratio of specific heats factor, dimensionless	$w$	Mass flow rate
$F_L$	Liquid pressure recovery factor, dimensionless	$x$	Ratio of pressure drop across the valve to upstream absolute static pressure ( $\Delta P/P_1$ ), dimensionless
$F_{LP}$	Combined liquid pressure recovery factor and piping geometry factor of valve with attached fittings (when there are no attached fittings, $F_{LP}$ equals $F_L$ ), dimensionless	$x_{\text{choked}}$	Choked pressure drop ratio for compressible flow
$F_P$	Piping geometry factor, dimensionless	$x_{\text{sizing}}$	Pressure drop ratio value used for compressible sizing
$K$	Head loss coefficient of a device, dimensionless (denoted with $\zeta$ in the sizing standards)	$x_T$	Pressure drop ratio factor at choked flow, dimensionless
$M$	Molecular weight	$x_{TP}$	Pressure drop ratio factor at choked flow with attached fittings, dimensionless
$N$	Numerical constant, used to account for different sets of units	$Y$	Expansion factor, dimensionless
$P_1$	Upstream absolute static pressure	$Z_1$	Compressibility factor at inlet conditions, dimensionless
$P_2$	Downstream absolute static pressure	$\gamma$	Ideal ratio of specific heats, dimensionless
$P_c$	Absolute thermodynamic critical pressure	$\nu$	Kinematic viscosity
$P_v$	Vapor pressure absolute of liquid at inlet temperature	$\rho_1$	Density at inlet conditions
		$\rho_1/\rho_o$	Liquid specific gravity at inlet (ratio of density of liquid at flowing temperature to density of water at 15.5°C (60°F)), dimensionless

1. Standard conditions are defined as 15.5°C (60°F) and 14.7 psia (101.3 kPa).

## 5.7 Equation Constants

		N	w	q	P <sup>(2)</sup>	ρ	T	d, D
N <sub>1</sub>		0.0865	---	m <sup>3</sup> /h	kPa	---	---	---
		0.865	---	m <sup>3</sup> /h	bar	---	---	---
		1.00	---	gpm	psia	---	---	---
N <sub>2</sub>		0.00214	---	---	---	---	---	mm
		890	---	---	---	---	---	inch
N <sub>5</sub>		0.00241	---	---	---	---	---	mm
		1000	---	---	---	---	---	inch
N <sub>6</sub>		2.73	kg/h	---	kPa	kg/m <sup>3</sup>	---	---
		27.3	kg/h	---	bar	kg/m <sup>3</sup>	---	---
		63.3	lb/h	---	psia	lbm/ft <sup>3</sup>	---	---
N <sub>8</sub>		0.948	kg/h	---	kPa	---	K	---
		94.8	kg/h	---	bar	---	K	---
		19.3	lb/h	---	psia	---	deg R	---
N <sub>9</sub> <sup>(3)</sup>	Normal Conditions	21.2	---	m <sup>3</sup> /h	kPa	---	K	---
	T <sub>N</sub> = 0°C	2120	---	m <sup>3</sup> /h	bar	---	K	---
	Standard Conditions	22.5	---	m <sup>3</sup> /h	kPa	---	K	---
	T <sub>s</sub> = 15°C	2250	---	m <sup>3</sup> /h	bar	---	K	---
	Standard Conditions T <sub>s</sub> = 60°F	7320	---	scfh	psia	---	deg R	---

1. Many of the equations used in these sizing procedures contain a numerical constant, N, along with a numerical subscript. These numerical constants provide a means for using different units in the equations. Values for the various constants and the applicable units are given in the above table. For example, if the flow rate is given in U.S. gpm and the pressures are psia, N<sub>1</sub> has a value of 1.00. If the flow rate is m<sup>3</sup>/hr and the pressures are kPa, the N<sub>1</sub> constant becomes 0.0865.

2. All pressures are absolute.

3. Pressure base is 101.3 kPa (1.013 bar)(14.7 psia).

## 5.8 Sizing Valves for Liquids

Following is a step-step procedure for the sizing of control valves for liquid flow using the ISA and IEC procedure. Strictly speaking, this sizing method is valid only for single component fluids, however multi-component mixtures can be used with care.

Each of these steps is important and must be considered during any valve sizing procedure. It is important to note that  $C_v$  values and  $F_L$  values are matched sets. If a different  $C_v$  is used, the corresponding  $F_L$  for that valve and valve travel must be obtained from the product literature.

1. Specify the variables required to size the valve as follows:

- Desired design,
- Process fluid (water, oil, etc.), and
- Appropriate service conditions
- $q$  or  $w$ ,  $P_1$ ,  $P_2$  or  $\Delta P$ ,  $T_1$ ,  $\rho_1/\rho_o$ ,  $P_v$ ,  $P_c$ , and  $v$

The ability to recognize which terms are appropriate for a specific sizing procedure can only be acquired through experience with different valve sizing problems. If any of the above terms appears to be new or unfamiliar, refer to the Abbreviations and Terminology table for a complete definition.

2. Determine the equation constants,  $N_1$  and  $N_2$ .

$N_1$  and  $N_2$  are numerical constants contained in the flow equations to provide a means for using different systems of units. Values for these various constants and their applicable units are given in the Equation Constants table.

3. Determine  $F_p$ , the piping geometry factor, and  $F_{LP}$ , the liquid pressure recovery factor adjusted for attached fittings.

For these calculations, an estimated  $C_v$  value and the corresponding  $F_L$  is used.

$F_p$  is a correction factor that accounts for pressure losses due to piping fittings such as reducers, elbows, or tees that might be attached directly to the inlet and outlet connections of the control valve to be sized. If such fittings are attached to the valve, these must be accounted for. The standard sizing procedure provides a method to calculate the  $F_p$  factor for concentric reducers and expanders. If, however, no fittings are attached to the valve,  $F_p$  has a value of 1.0 and simply drops out of the sizing equation. Also,  $F_{LP} = F_L$ .

4. Determine the pressure drop to use for sizing,  $\Delta P_{sizing}$ .

When the difference between the upstream and downstream pressure is high enough, the liquid may start to vaporize, causing choked flow. If the actual pressure drop across the valve,  $\Delta P$ , is higher than the pressure drop that causes choked flow, the choked flow pressure drop,  $\Delta P_{choked}$ , must be used in place of the actual pressure drop.

5. Calculate  $C_v$ . If this  $C_v$  value is not close to the estimate used in step 3, iterate using this new  $C_v$  value and the corresponding  $F_L$  from the product information.

### 5.8.1 Determining the Piping Geometry Factor ( $F_p$ ) and the Liquid Pressure-Recovery Factor ( $F_{LP}$ ) Adjusted for Fittings

Determine an  $F_p$  factor if any fittings such as reducers, elbows, or tees will be directly attached to the inlet and outlet connections of the control valve that is to be sized. When possible, it is recommended that  $F_p$  and  $F_{LP}$  factors be determined experimentally by using the specified valve in actual tests.

$$F_p = \left[ 1 + \frac{\Sigma K}{N_2} \left( \frac{C_v}{d^2} \right)^2 \right]^{-1/2}$$

However, using the following method, reasonable approximations can be made for attached concentric reducers.

In the previous equation, the  $\Sigma K$  term is the algebraic sum of the velocity head loss coefficients of all of the fittings that are attached to the control valve.

$$\Sigma K = K_1 + K_2 + K_{B1} - K_{B2}$$

Where,

$K_1$  = Resistance coefficient of upstream fittings

$K_2$  = Resistance coefficient of downstream fittings

$K_{B1}$  = Inlet Bernoulli coefficient

$K_{B2}$  = Outlet Bernoulli coefficient

And,

$$K_{B1} = 1 - \left(\frac{d}{D_1}\right)^4$$

$$K_{B2} = 1 - \left(\frac{d}{D_2}\right)^4$$

If the upstream and downstream piping are of equal size, the Bernoulli coefficients are also equal,  $K_{B1} = K_{B2}$ , and therefore they are dropped from the  $\Sigma K$  equation.

The most commonly used fitting in control valve installations is the short-length concentric reducer. The equations for this fitting are as follows:

- For an inlet reducer:

$$K_1 = 0.5 \left(1 - \frac{d^2}{D_1^2}\right)^2$$

- For an outlet reducer:

$$K_2 = 1.0 \left(1 - \frac{d^2}{D_2^2}\right)^2$$

- For a valve installed between identical reducers:

$$K_1 + K_2 = 1.5 \left(1 - \frac{d^2}{D^2}\right)^2$$

Using the  $F_L$  value corresponding to the  $C_v$  value for the selected valve,

$$F_{LP} = \left[ \frac{K_1 + K_{B1}}{N_2} \left(\frac{C_v}{d^2}\right)^2 + \frac{1}{F_L^2} \right]^{-1/2}$$

### 5.8.2 Determining the Pressure Drop to Use for Sizing ( $\Delta P_{sizing}$ )

Calculate the liquid critical pressure ratio factor:

$$F_F = 0.96 - 0.28 \sqrt{\frac{P_v}{P_c}}$$

Then, determine the limiting pressure drop due to liquid choking:

$$\Delta P_{choked} = \left(\frac{F_{LP}}{F_P}\right)^2 (P_1 - F_F P_v)$$

The pressure drop to use in calculating the required flow coefficient,  $\Delta P_{sizing}$ , is then the lesser of the actual system pressure drop,  $\Delta P$ , and the choked pressure drop,  $\Delta P_{choked}$ .

Note: If  $\Delta P_{choked} < \Delta P$ , the flow is either cavitating or flashing. If the outlet pressure is greater than the vapor pressure of the fluid, cavitation is causing the choked flow. If the outlet pressure is less than the vapor pressure of the fluid, the flow is flashing. See the section later in this chapter on cavitation and flashing for more information.

### 5.8.3 Calculating the Required Flow Coefficient ( $C_v$ )

The valve flow coefficient required to pass the given amount of flow is calculated as follows:

$$C_v = \frac{q}{N_1 F_P \sqrt{\frac{\Delta P_{sizing}}{\rho_1 / \rho_o}}}$$

### 5.8.4 Liquid Sizing Sample Problem

Assume an installation that, at initial plant start-up, will not be operating at maximum design capability. The lines are sized for the ultimate system capacity, but there is a desire to install a control valve now which is sized only for currently anticipated requirements. The line size is 8 inches, and a Class 300 globe valve with an equal-percentage cage has been specified.

Standard concentric reducers will be used to install the valve into the line. Determine the appropriate valve size.

1. Specify the variables necessary to size the valve:

- Desired valve design - Class 300 globe valve with an equal-percentage cage and assumed valve size of 3 inches, this valve has a 100% open  $C_v$  of 121 with  $F_L$  of 0.89

- Process fluid - liquid propane

- Service conditions -

$$q = 800 \text{ gpm}$$

$$P_1 = 300 \text{ psig} = 314.7 \text{ psia}$$

$$P_2 = 275 \text{ psig} = 289.7 \text{ psia}$$

$$\Delta P = 25 \text{ psi}$$

$$T_1 = 21^\circ\text{C} (70^\circ\text{F})$$

$$\rho_1/\rho_o = 0.50$$

$$P_v = 124.3 \text{ psia}$$

$$P_c = 616.3 \text{ psia}$$

2. Determine the equation constants,  $N_1$  and  $N_2$ .

From the Equation Constants table,  $N_1 = 1.0$  and  $N_2 = 890$ .

3. Determine  $F_p$ , the piping geometry factor, and  $F_{LP}$ , the liquid pressure recovery factor adjusted for attached fittings.

- First, find the necessary resistance coefficients needed when the upstream and downstream pipe sizes are the same:

$$\begin{aligned} K_1 &= 0.5 \left( 1 - \frac{d^2}{D_1^2} \right)^2 \\ &= 0.5 \left( 1 - \frac{3^2}{7.98^2} \right)^2 \\ &= 0.37 \end{aligned}$$

And

$$\begin{aligned} K_{B1} &= 1 - \left( \frac{d}{D_1} \right)^4 \\ &= 1 - \left( \frac{3}{7.98} \right)^4 \\ &= 0.98 \end{aligned}$$

And

$$\begin{aligned} \Sigma K &= 1.5 \left( 1 - \frac{d^2}{D^2} \right)^2 \\ &= 1.5 \left( 1 - \frac{3^2}{7.98^2} \right)^2 \\ &= 1.11 \end{aligned}$$

- Now, calculate  $F_p$ :

$$\begin{aligned} F_p &= \left[ 1 + \frac{\Sigma K}{N_2} \left( \frac{C_v}{d^2} \right)^2 \right]^{-1/2} \\ &= \left[ 1 + \frac{1.11}{890} \left( \frac{121}{3^2} \right)^2 \right]^{-1/2} \\ &= 0.90 \end{aligned}$$

- Then, calculate  $F_{LP}$ :

$$\begin{aligned} F_{LP} &= \left[ \frac{K_1 + K_{B1}}{N_2} \left( \frac{C_v}{d^2} \right)^2 + \frac{1}{F_L^2} \right]^{-1/2} \\ &= \left[ \frac{0.37 + 0.98}{890} \left( \frac{121}{3^2} \right)^2 + \frac{1}{0.89^2} \right]^{-1/2} \\ &= 0.81 \end{aligned}$$

4. Determine the pressure drop to use for sizing,  $\Delta P_{sizing}$

- First, find the liquid critical pressure ratio factor:

$$\begin{aligned} F_F &= 0.96 - 0.28 \sqrt{\frac{P_v}{P_c}} \\ &= 0.96 - 0.28 \sqrt{\frac{124.3}{616.3}} \\ &= 0.83 \end{aligned}$$

- The choked pressure drop,  $\Delta P_{sizing}$ , is found as follows:

$$\begin{aligned} \Delta P_{choked} &= \left(\frac{F_{LP}}{F_P}\right)^2 (P_1 - F_F P_v) \\ &= \left(\frac{0.81}{0.90}\right)^2 (314.7 - 0.83 \cdot 124.3) \\ &= 171 \text{ psi} \end{aligned}$$

- Since the actual pressure drop is lower than the choked pressure drop:

$$\begin{aligned} \Delta P_{sizing} &= \Delta P \\ &= 25 \text{ psi} \end{aligned}$$

5. Calculate the required  $C_v$  value.

$$\begin{aligned} C_v &= \frac{q}{N_1 F_P \sqrt{\frac{\Delta P_{sizing}}{\rho_1/\rho_o}}} \\ &= \frac{800}{1.0 \cdot 0.9 \sqrt{\frac{25}{0.5}}} \\ &= 125.7 \end{aligned}$$

The required  $C_v$  of 125.7 exceeds the capacity of the assumed valve, which has a  $C_v$  of 121. Although for this example it may be obvious that the next larger size (NPS 4 (DN 100)) would be the correct valve size, this may not always be true,

and a repeat of the above procedure should be carried out.

Now, assume a NPS 4 (DN 100) valve,  $C_v = 203$  and  $F_L = 0.91$ . These values were determined from the flow coefficient table for a Class 300, NPS 4 (DN 100) Fisher ES globe valve with an equal-percentage cage.

Recalculate the required  $C_v$  using an assumed  $C_v$  value of 203 in the  $F_P$  calculation

$$\begin{aligned} \Sigma K &= 1.5 \left(1 - \frac{d^2}{D^2}\right)^2 \\ &= 1.5 \left(1 - \frac{4^2}{7.98^2}\right)^2 \\ &= 0.84 \end{aligned}$$

And

$$\begin{aligned} F_P &= \left[1 + \frac{\Sigma K \left(\frac{C_v}{d^2}\right)^2}{N_2}\right]^{-1/2} \\ &= \left[1 + \frac{0.84 \left(\frac{203}{4^2}\right)^2}{890}\right]^{-1/2} \\ &= 0.93 \end{aligned}$$

And

$$\begin{aligned} C_v &= \frac{q}{N_1 F_P \sqrt{\frac{\Delta P_{sizing}}{\rho_1/\rho_o}}} \\ &= \frac{800}{1.0 \cdot 0.93 \sqrt{\frac{25}{0.5}}} \\ &= 121.7 \end{aligned}$$

This solution indicates only that the NPS 4 (DN 100) valve is large enough to satisfy the service conditions given. There may be cases, however, where a more accurate prediction of the  $C_v$  is required. In such cases, the required  $C_v$  should be redetermined using a new  $F_P$  value based on the  $C_v$  value obtained above.

In this example,  $C_v$  is 121.7, which leads to the following result:

$$F_p = \left[ 1 + \frac{\Sigma K}{N_2} \left( \frac{C_v}{d^2} \right)^2 \right]^{-1/2}$$

$$= \left[ 1 + \frac{0.84}{890} \left( \frac{121.7}{4^2} \right)^2 \right]^{-1/2}$$

$$= 0.97$$

And

$$C_v = \frac{q}{N_1 F_p \sqrt{\frac{\Delta P_{sizing}}{\rho_1 / \rho_o}}}$$

$$= \frac{800}{1.0 \cdot 0.97 \sqrt{\frac{25}{0.5}}}$$

$$= 116.6$$

Because this newly determined  $C_v$  is very close to the  $C_v$  used initially for this recalculation (116.6 versus 121.7), the valve sizing procedure is complete, and the conclusion is that a NPS 4 (DN 100) valve opened to about 75% of total travel should be adequate for the required specifications. Note that for this case, it was not needed to update the  $F_L$  and  $F_{LP}$  values. If the  $F_L$  value were to change between iterations, these values would need to be updated, and the  $C_v$  recalculated.

## 5.9 Sizing Valves for Compressible Fluids

Following is a six-step procedure for the sizing of control valves for compressible flow using the ISA standardized procedure. Each of these steps is important and must be considered during any valve sizing procedure.

1. Specify the necessary variables required to size the valve as follows:

- Desired valve design (e.g. balanced globe with linear cage),
- Process fluid (air, natural gas, steam, etc.) and
- Appropriate service conditions —  $q$  or  $w$ ,  $P_1$ ,  $P_2$  or  $\Delta P$ ,  $T_1$ ,  $M$ ,  $\gamma$ , and  $Z_1$  or  $\rho_1$

The ability to recognize which terms are appropriate for a specific sizing procedure can only be acquired through experience with different valve sizing problems. If any of the above terms appear to be new or unfamiliar, refer to the Abbreviations and Terminology table for a complete definition.

2. Determine the equation constants,  $N_2$ ,  $N_5$ , and  $N_6$ ,  $N_8$ , or  $N_9$ , depending on the available process data and the units used.

These N values are numerical constants contained in the flow equations to provide a means for using different systems of units. Values for these various constants and their applicable units are given in the Equation Constants table.  $N_6$  is used when the flow rate is given in mass flow units and the density,  $\rho_1$  is known. If, instead of density the compressibility is known,  $N_8$  is used for mass flow rate units and  $N_9$  is used for standard volumetric flow rate units.

3. Determine  $F_p$ , the piping geometry factor, and  $x_{TP}$ , the pressure drop ratio factor adjusted for attached fittings.

For these calculations, an estimated  $C_v$  value and the corresponding  $x_{TP}$  is used.

$F_p$  is a correction factor that accounts for pressure losses due to piping fittings such as reducers, elbows, or tees that might be attached directly to the inlet and outlet connections of the control valve to be sized. If such fittings are attached to the valve, these must be accounted for. The standard sizing procedure provides a method to calculate the  $F_p$  factor for concentric reducers and expanders. If, however,



no fittings are attached to the valve,  $F_p$  has a value of 1.0 and simply drops out of the sizing equation and  $x_{TP} = x_T$ . The equations for calculating  $F_p$  are in the section Sizing Valves for Liquids.

4. Determine the pressure drop ratio to use for sizing,  $x_{sizing}$ , and the expansion factor,  $Y$ .

When the difference between the upstream and downstream pressure is high enough, the flow may become choked. If the actual pressure drop ratio across the valve,  $x$ , is higher than the pressure drop ratio that causes choked flow, the choked flow pressure drop ratio,  $x_{choked}$ , must be used in place of the actual pressure drop. When the flow is choked, the expansion factor will be equal to 2/3.

5. Calculate  $C_v$ .

If this  $C_v$  value is not close to the estimate used in step 3, iterate using this new  $C_v$  value and the corresponding  $x_T$  from the product information.

### 5.9.1 Determining the Piping Geometry Factor ( $F_p$ ) and the Pressure Drop Ratio Factor ( $x_{TP}$ ) at Choked Flow with Attached Fittings

The value of  $F_p$  for compressible flow sizing is obtained in the same manner as with liquid sizing. See the section on liquid sizing for the equations  $F_p$  and the associated resistance coefficients.

$x_{TP}$  is found using the following equation, using the  $x_T$  value corresponding to the selected valve's  $C_v$ :

$$x_{TP} = \frac{\frac{x_T}{F_p^2}}{1 + \frac{x_T(K_1 + K_{B1})}{N_5} \left(\frac{C_v}{d^2}\right)^2}$$

### 5.9.2 Determining the Pressure Drop Ratio to Use for Sizing ( $x_{sizing}$ ) and the Expansion Factor ( $Y$ )

First, find the specific heat ratio factor,  $F_y$ :

$$F_y = \frac{Y}{1.4}$$

Then, find the choked flow pressure drop ratio:

$$x_{choked} = F_y \cdot x_{TP}$$

The pressure drop ratio to use in calculating the required flow coefficient,  $x_{sizing}$ , is then the lesser of the actual system pressure drop,  $x$ , and the choked pressure drop,  $x_{choked}$ .

The expansion factor is calculated using both  $x_{sizing}$  and  $x_{choked}$ :

$$Y = 1 - \frac{x_{sizing}}{3 \cdot x_{choked}}$$

### 5.9.3 Calculating Flow Coefficient ( $C_v$ )

One of following three equations is used to calculate  $C_v$ , depending on the form of the process data.

- For mass flow rate and density:

$$C_v = \frac{w}{N_6 F_p Y \sqrt{x_{sizing} P_1 \rho_1}}$$

- For mass flow rate and compressibility:

$$C_v = \frac{w}{N_8 F_p P_1 Y} \sqrt{\frac{T_1 Z_1}{x_{sizing} M}}$$

- For standard volumetric flow rate and compressibility:

$$C_v = \frac{q}{N_9 F_p P_1 Y} \sqrt{\frac{M T_1 Z_1}{x_{sizing}}}$$

### 5.9.4 Compressible Fluid Sizing

#### Sample Problem No. 1

Determine the size and percent opening for a Fisher V250 ball valve operating with the following service conditions. Assume that the valve and line size are equal.

1. Specify the necessary variables required to size the valve:

- Desired valve design: Fisher V250 valve
- Process fluid: Natural gas
- Service conditions:
  - $P_1 = 200 \text{ psig} = 214.7 \text{ psia}$
  - $P_2 = 50 \text{ psig} = 64.7 \text{ psia}$
  - $\Delta P = 150 \text{ psi}$
  - $x = \Delta P/P_1 = 150/214.7 = 0.70$
  - $T_1 = 60^\circ\text{F} = 520^\circ\text{R}$
  - $M = 17.38$
  - $Z_1 = 1$
  - $\gamma = 1.31$
  - $q = 6.0 \times 10^6 \text{ scfh}$

2. Determine the equation constants,  $N_2$ ,  $N_5$ , and  $N_6$ ,  $N_8$ , or  $N_9$ .

For these units, according to the Equation Constants table,  $N_2 = 890$  and  $N_5 = 1000$ . For conditions given in standard volumetric flow rate in scfh and compressibility, use  $N_9 = 7320$ .

3. Determine  $F_p$ , the piping geometry factor, and  $x_{TP}$ , the pressure drop ratio factor adjusted for attached fittings.

Since the valve is line-sized and there are no attached fittings,  $F_p = 1$  and  $x_{TP} = x_T$ . For an NPS 8 (DN 200) V250 valve at 100% travel,  $x_T = 0.14$ .

4. Determine the pressure drop ratio to use for sizing,  $x_{sizing}$ , and the expansion factor,  $Y$ .

Start by calculating the specific heat ratio factor,  $F_\gamma$ :

$$\begin{aligned} F_\gamma &= \frac{\gamma}{1.4} \\ &= \frac{1.31}{1.4} \\ &= 0.94 \end{aligned}$$

Use this value to find the choked pressure drop ratio:

$$\begin{aligned} x_{choked} &= F_\gamma x_{TP} \\ &= 0.94 \cdot 0.14 \\ &= 0.131 \end{aligned}$$

The choked flow pressure drop ratio is less than the actual pressure drop ratio, so:

$$x_{sizing} = x_{choked} = 0.131$$

The expansion factor,  $Y$ , is:

$$Y = 1 - \frac{x_{sizing}}{3x_{choked}} = 0.667$$

5. Calculate  $C_v$ .

$$\begin{aligned} C_v &= \frac{q}{N_9 F_p P_1 Y} \sqrt{\frac{M T_1 Z_1}{x_{sizing}}} \\ &= \frac{6.0 \times 10^6}{7320 \cdot 1.0 \cdot 214.7 \cdot 0.667} \sqrt{\frac{17.38 \cdot 520 \cdot 1.0}{0.131}} \\ &= 1504 \end{aligned}$$

This result indicates that the valve is adequately sized to pass the flow (rated  $C_v = 2190$ ). To determine the percent valve opening, note that the required  $C_v$  occurs at approximately 83 degrees for the selected valve. Note also that, at 83 degrees opening, the  $x_T$  value is 0.219, which is substantially different from the rated value of 0.137 used initially in the problem. The next step is to rework the problem using the  $x_T$  value for 83 degrees travel.

Recalculate  $x_{\text{choked}}$ :

$$\begin{aligned}x_{\text{choked}} &= F_y x_{TP} \\ &= 0.94 \cdot 0.219 \\ &= 0.205\end{aligned}$$

The flow is still choked, so the required  $C_v$  is now:

$$\begin{aligned}C_v &= \frac{q}{N_9 F_p P_1 Y} \sqrt{\frac{M T_1 Z_1}{x_{\text{sizing}}}} \\ &= \frac{6.0 \times 10^6}{7320 \cdot 1.0 \cdot 214.7 \cdot 0.667} \sqrt{\frac{17.38 \cdot 520 \cdot 1.0}{0.219}} \\ &= 1203\end{aligned}$$

The reason that the required  $C_v$  has dropped so dramatically is attributable solely to the difference in the  $x_T$  values at rated and 83 degrees travel.

Continuing this process until a final required  $C_v$  is obtained results in  $C_v = 923$  and  $x_T = 0.372$  at about 74 degrees travel. ■

### 5.9.5 Compressible Fluid Sizing Sample Problem No. 2

Assume steam is to be supplied to a process designed to operate at 250 psig (17.2 bar). The supply source is a header maintained at 500 psig (34.5 bar) and 260°C (500°F). A NPS 6 (DN 150) standard schedule line from the steam main to the process is being planned. Also, make the assumption that if the required valve size is less than NPS 6 (DN 150), it will be installed using concentric reducers. Determine the appropriate Fisher ED valve with a linear cage.

1. Specify the necessary variables required to size the valve:

- Desired valve design: Class 300 Fisher ED valve with a linear cage. Assume valve size is NPS 4 (DN 100).
- Process fluid: superheated steam

- 6-inch standard schedule pipe has  $D = 6.1$  inches

■ Service conditions:

$$w = 125,000 \text{ lb/h}$$

$$P_1 = 500 \text{ psig} = 514.7 \text{ psia}$$

$$P_2 = 250 \text{ psig} = 264.7 \text{ psia}$$

$$\Delta P = 250 \text{ psi}$$

$$x = \Delta P / P_1 = 250 / 514.7 = 0.49$$

$$T_1 = 260^\circ\text{C} (500^\circ\text{F})$$

$$\rho_1 = 1.042 \text{ lbm/ft}^3$$

$$\gamma = 1.33$$

- Start by trying a NPS 4 (DN 100) ED valve with linear trim at 100% travel:

$$C_v = 236$$

$$x_T = 0.690$$

2. Determine the equation constants,  $N_2$ ,  $N_5$ , and  $N_6$ ,  $N_8$ , or  $N_9$ .

For these units, according to the Equation Constants table,  $N_2 = 890$  and  $N_5 = 1000$ . For conditions given in mass flow rate in lb/hr and density in lbm/ft<sup>3</sup>, use  $N_6 = 63.3$ .

3. Determine  $F_p$ , the piping geometry factor, and  $x_{TP}$ , the pressure drop ratio factor adjusted for attached fittings.

Since the upstream and downstream pipes are the same size, the resistance coefficients needed are:

$$\begin{aligned}K_1 &= 0.5 \left( 1 - \frac{d^2}{D_1^2} \right)^2 \\ &= 0.5 \left( 1 - \frac{4^2}{6.1^2} \right)^2 \\ &= 0.16\end{aligned}$$

$$\begin{aligned}
 K_{B1} &= 1 - \left(\frac{d}{D_1}\right)^4 \\
 &= 1 - \left(\frac{4}{6.1}\right)^4 \\
 &= 0.82
 \end{aligned}$$

And

$$\begin{aligned}
 \Sigma K &= 1.5 \left(1 - \frac{d^2}{D^2}\right)^2 \\
 &= 1.5 \left(1 - \frac{4^2}{6.1^2}\right)^2 \\
 &= 0.49
 \end{aligned}$$

Now, calculate  $F_p$ :

$$\begin{aligned}
 F_p &= \left[1 + \frac{\Sigma K}{N_2} \left(\frac{C_v}{d^2}\right)^2\right]^{-1/2} \\
 &= \left[1 + \frac{0.49}{890} \left(\frac{236}{4^2}\right)^2\right]^{-1/2} \\
 &= 0.945
 \end{aligned}$$

Finally, calculate  $x_{TP}$ :

$$\begin{aligned}
 x_{TP} &= \frac{\frac{x_T}{F_p^2}}{1 + \frac{x_T(K_1 + K_{B1})}{N_5} \left(\frac{C_v}{d^2}\right)^2} \\
 &= \frac{\frac{0.69}{0.945^2}}{1 + \frac{0.69(0.16 + 0.82)}{1000} \left(\frac{236}{4^2}\right)^2} \\
 &= 0.67
 \end{aligned}$$

4. Determine the pressure drop ratio to use for sizing,  $x_{sizing}$ , and the expansion factor,  $Y$ .

Start by calculating the specific heat ratio factor,  $F_y$ :

$$\begin{aligned}
 F_y &= \frac{\gamma}{1.4} \\
 &= \frac{1.33}{1.4} \\
 &= 0.95
 \end{aligned}$$

Use this value to find the choked pressure drop ratio:

$$\begin{aligned}
 x_{choked} &= F_y x_{TP} \\
 &= 0.95 \cdot 0.67 \\
 &= 0.64
 \end{aligned}$$

The choked flow pressure drop ratio is greater than the actual pressure drop ratio, so:

$$x_{sizing} = x = 0.49$$

The expansion factor,  $Y$ , is:

$$Y = 1 - \frac{x_{sizing}}{3x_{choked}} = 0.75$$

5. Calculate  $C_v$

$$\begin{aligned}
 C_v &= \frac{W}{N_6 F_p Y \sqrt{x_{sizing} P_1 \rho_1}} \\
 &= \frac{125,000}{63.3 \cdot 0.945 \cdot 0.75 \sqrt{0.49 \cdot 514.7 \cdot 1.042}} \\
 &= 173
 \end{aligned}$$

Iterating using  $x_T$  values from the product catalog results in a required  $C_v = 169$  and  $x_T = 0.754$ . This occurs at about 66% open, so the NPS 4 (DN 100) ED valve with linear trim would be an acceptable solution with respect to capacity. The next smaller size of ED valve with linear trim has a rated  $C_v$  of only 148, so it would not be an appropriate valve for this situation. ■

## 5.10 Representative Sizing Coefficients

### 5.10.1 Representative Sizing Coefficients for Single-Ported, Globe-Style Valve Bodies

Valve Size (NPS)	Valve Plug Style	Flow Characteristic	Port Dia. (in.)	Rated Travel (in.)	$C_v$	$F_L$	$X_T$	$F_D$
1/2	Post-Guided	Equal-Percentage	0.38	0.50	2.41	0.90	0.54	0.61
3/4	Post-Guided	Equal-Percentage	0.56	0.50	5.92	0.84	0.61	0.61
1	Micro-Form	Equal-Percentage	3/8	3/4	3.07	0.89	0.66	0.72
	---	---	1/2	3/4	4.91	0.93	0.80	0.67
	---	---	3/4	3/4	8.84	0.97	0.92	0.62
	Cage-Guided	Linear	1-5/16	3/4	20.6	0.84	0.64	0.34
Equal-Percentage		1-5/16	3/4	17.2	0.88	0.67	0.38	
1-1/2	Micro-Form	Equal-Percentage	3/8	3/4	3.20	0.84	0.65	0.72
	---	---	1/2	3/4	5.18	0.91	0.71	0.67
	---	---	3/4	3/4	10.2	0.92	0.80	0.62
	Cage-Guided	Linear	1-7/8	3/4	39.2	0.82	0.66	0.34
Equal-Percentage		1-7/8	3/4	35.8	0.84	0.68	0.38	
2	Cage-Guided	Linear	2-5/16	1-1/8	72.9	0.77	0.64	0.33
		Equal-Percentage	2-5/16	1-1/8	59.7	0.85	0.69	0.31
3	Cage-Guided	Linear	3-7/16	1-1/2	148	0.82	0.62	0.30
		Equal-Percentage			136	0.82	0.68	0.32
4	Cage-Guided	Linear	4-3/8	2	236	0.82	0.69	0.28
		Equal-Percentage			224	0.82	0.72	0.28
6	Cage-Guided	Linear	7	2	433	0.84	0.74	0.28
		Equal-Percentage			394	0.85	0.78	0.26
8	Cage-Guided	Linear	8	3	846	0.87	0.81	0.31
		Equal-Percentage			818	0.86	0.81	0.26

### 5.10.2 Representative Sizing Coefficients for Rotary Valves

Valve Size (NPS)	Valve Style	Degrees of Valve Opening	C <sub>v</sub>	F <sub>L</sub>	X <sub>T</sub>	F <sub>D</sub>
1	V-Notch Ball Valve	60	15.6	0.86	0.53	---
		90	34.0	0.86	0.42	---
1-1/2	V-Notch Ball Valve	60	28.5	0.85	0.50	---
		90	77.3	0.74	0.27	---
2	V-Notch Ball Valve	60	59.2	0.81	0.53	---
		90	132	0.77	0.41	---
	High-Performance Butterfly Valve	60	58.9	0.76	0.50	0.49
		90	80.2	0.71	0.44	0.70
3	V-Notch Ball Valve	60	120	0.80	0.50	0.92
		90	321	0.74	0.30	0.99
	High-Performance Butterfly Valve	60	115	0.81	0.46	0.49
		90	237	0.64	0.28	0.70
4	V-Notch Ball Valve	60	195	0.80	0.52	0.92
		90	596	0.62	0.22	0.99
	High-Performance Butterfly Valve	60	270	0.69	0.32	0.49
		90	499	0.53	0.19	0.70
6	V-Notch Ball Valve	60	340	0.80	0.52	0.91
		90	1100	0.58	0.20	0.99
	High-Performance Butterfly Valve	60	664	0.66	0.33	0.49
		90	1260	0.55	0.20	0.70
8	V-Notch Ball Valve	60	518	0.82	0.54	0.91
		90	1820	0.54	0.18	0.99
	High-Performance Butterfly Valve	60	1160	0.66	0.31	0.49
		90	2180	0.48	0.19	0.70
10	V-Notch Ball Valve	60	1000	0.80	0.47	0.91
		90	3000	0.56	0.19	0.99
	High-Performance Butterfly Valve	60	1670	0.66	0.38	0.49
		90	3600	0.48	0.17	0.70
12	V-Notch Ball Valve	60	1530	0.78	0.49	0.92
		90	3980	0.63	0.25	0.99
	High-Performance Butterfly Valve	60	2500	---	---	0.49
		90	5400	---	---	0.70
16	V-Notch Ball Valve	60	2380	0.80	0.45	0.92
		90	8270	0.37	0.13	1.00
	High-Performance Butterfly Valve	60	3870	0.69	0.40	---
		90	8600	0.52	0.23	---

## 5.11 Actuator Sizing

Actuators are selected by matching the force required to stroke the valve with an actuator that can supply that force. For rotary valves a similar process matches the torque required to stroke the valve with an actuator that will supply that torque. The same fundamental process is used for pneumatic, electric, and electro-hydraulic actuators.

### 5.11.1 Globe Valves

The force required to operate a globe valve includes:

- Force to overcome static unbalance of the valve plug
- Force to provide a seat load
- Force to overcome packing friction
- Additional forces required for certain specific applications or constructions

Total force required = A + B + C + D

#### 5.11.1.1 Unbalance Force (A)

The unbalance force is that resulting from fluid pressure at shutoff and in the most general sense can be expressed as:

Unbalance force = net pressure differential X net unbalance area

Frequent practice is to take the maximum upstream gauge pressure as the net pressure differential unless the process design always ensures a back pressure at the maximum inlet pressure. Net unbalance area is the port area on a single-seated, flow-up design. Unbalance area may have to take into account the stem area depending on configuration. For balanced valves there is still a small unbalance area. This data can be obtained from the manufacturer. Typical port areas for balance valves flow up and unbalanced valves in a flow down configuration are listed.

Port Diameter	Unbalance Area - Single-Seated, Unbalanced Valves	Unbalance Area - Balanced Valves
1/4	0.028	---
3/8	0.110	---
1/2	0.196	---
3/4	0.441	---
1	0.785	---
1-5/16	1.35	0.04
1-7/8	2.76	0.062
2-5/16	4.20	0.27
3-7/16	9.28	0.118
4-3/8	15.03	0.154
7	38.48	0.81
8	50.24	0.86

Figure 5.2 Typical Unbalance Areas of Control Valves

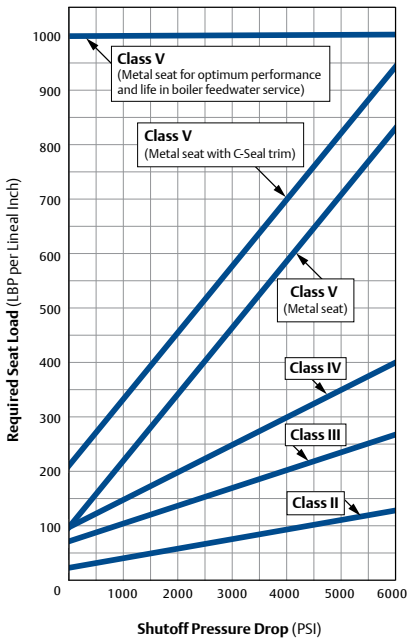

Figure 5.3 Minimum Required Seat Load for Improved Seat Life on Metal-Seated Valves Class II-V

Leak Class	Recommended Seat Load
Class I	As required by user specification, no factory leak test required
Class II	20 pounds per lineal inch of port circumference
Class III	40 pounds per lineal inch of port circumference
Class IV	Standard (Lower) Seat Only—40 pounds per lineal inch of port circumference (up through a 4-3/8 inch diameter port)
	Standard (Lower) Seat Only—80 pounds per lineal inch of port circumference (larger than 4-3/8 inch diameter port)
Class V	Metal Seat—determine pounds per lineal inch of port circumference from Figure 5.2
Class VI	Metal Seat—300 pounds per lineal inch of port circumference

Figure 5.4 Recommended Seat Load

### 5.11.1.2 Force to Provide Seat Load (B)

Seat load, usually expressed in pounds per lineal inch of port circumference, is determined by shutoff requirements. Use the following guidelines to determine the seat load required to meet the factory acceptance tests for ANSI/FCI 70-2 and IEC 60534-4 leak classes II through VI. See table for recommended seat load.

Because of differences in the severity of service conditions, do not construe these leak classifications and corresponding leakage rates as indicators of field performance. To prolong seat life and shutoff capabilities, use a higher than recommended seat load. See Figure 5.3 for suggested seat loads. If tight shutoff is not a prime consideration, use a lower leak class.

### 5.11.1.3 Packing Friction (C)

Packing friction is determined by stem size, packing type, and the amount of compressive load placed on the packing by the process or the bolting.

Packing friction is not 100% repeatable in its friction characteristics. Live-loaded packing designs can have significant friction forces especially if graphite packing is used. The table lists typical packing friction values.

### 5.11.1.4 Additional Forces (D)

Additional forces may be required to stroke the valve such as: bellow stiffness; unusual frictional forces resulting from seals; or special seating forces for soft metal seals as an example. The manufacturer should either supply this information or take it into account when sizing an actuator.



Stem Size (inches)	Class	PTFE Packing		Graphite Ribbon / Filament
		Single	Double	
5/16	All	20	30	---
3/8	125	38	56	---
	150			125
	250			---
	300			190
	600			250
	900			320
	1500			380
1/2	125	50	75	---
	150			180
	250			---
	300			230
	600			320
	900			410
	1500			500
	2500			590
5/8	125	63	95	---
	150			218
	250			---
	300			290
	600			400
3/4	125	75	112.5	---
	150			350
	250			---
	300			440
	600			660
	900			880
	1500			1100
	2500			1320
1	300	100	150	610
	600			850
	900			1060
	1500			1300
	2500			1540
1-1/4	300	120	180	800
	600			1100
	900			1400
	1500			1700
	2500			2040
2	300	200	300	1225
	600			1725
	900			2250
	1500			2750
	2500			3245

Note: Values shown are frictional forces typically encountered when using standard packing flange bolt torquing procedures.

Figure 5.5 Typical Packing Friction Values

### 5.11.2 Actuator Force Calculations

Pneumatic diaphragm actuators provide a net force with the additional air pressure after compressing the spring in air to close, or with the net precompression of the spring in air to open. This may be calculated in pounds per square inch of pressure differential.

For example: Suppose 275 lbf. is required to close the valve calculated following the process described earlier. An air-to-open actuator with 100 square inches of diaphragm area and a bench set of 6 to 15 psig is one available option. The expected operating range is 3 to 15 psig. The precompression can be calculated as the difference between the lower end of the bench set (6 psig) and the beginning of the operating range (3 psig). This 3 psig is used to overcome the precompression so the net precompression force must be:

$$3 \text{ psig} \times 100 \text{ sq. in.} = 300 \text{ lbf.}$$

This exceeds the force required and is an adequate selection.

Piston actuators with springs are sized in the same manner. The thrust from piston actuators without springs can simply be calculated as:

$$(\text{Piston Area})(\text{Minimum Supply Pressure}) = \text{Available Thrust}$$

(Be careful to maintain compatibility of units)

In some circumstances an actuator could supply too much force and cause the stem to buckle, to bend sufficiently to cause a leak, or to damage valve internals. This could occur because the actuator is too large or the maximum air supply exceeds the minimum air supply available.

The manufacturer normally takes responsibility for actuator sizing and should have methods documented to check for maximum stem loads.

Manufacturers also publish data on

actuator thrusts, effective diaphragm areas, and spring data. ■

## 5.12 Actuator Sizing for Rotary Valves

In selecting the most economical actuator for a rotary valve, the determining factors are the torque required to open and close the valve and the torque output of the actuator.

This method assumes the valve has been properly sized for the application and the application does not exceed pressure limitations for the valve.

### 5.12.1 Torque Equations

Rotary valve torque equals the sum of a number of torque components. To avoid confusion, a number of these have been combined and a number of calculations have been performed in advance. Thus, the torques required for each valve type can be represented with two simple and practical equations.

### 5.12.2 Breakout Torque

$$T_B = A(\Delta P_{\text{shutoff}}) + B$$

### 5.12.3 Dynamic Torque

$$T_D = C(\Delta P_{\text{eff}})$$

The specific A, B, and C factors for each valve design are included in following tables. ■

## 5.13 Typical Rotary Valve Torque Factors

### 5.13.1 Torque Factors for V-Notch Ball Valve with Composition Seal

Valve Size (NPS)	Valve Shaft Diameter (inches)	A	B	C		Maximum $T_D$ , LBF • IN.
		Composition Bearings		60°	70°	
2	1/2	0.15	80	0.11	0.60	515
3	3/4	0.10	280	0.15	3.80	2120
4	3/4	0.10	380	1.10	18.0	2120
6	1	1.80	500	1.10	36.0	4140
8	1-1/4	1.80	750	3.80	60.0	9820
10	1-1/4	1.80	1250	3.80	125	9820
12	1-1/2	4.00	3000	11.0	143	12,000
14	1-3/4	42	2400	75	413	23,525
16	2	60	2800	105	578	23,525
18	2-1/8	60	2800	105	578	55,762
20	2-1/2	97	5200	190	1044	55,762

### 5.13.2 Torque Factors for High-Performance Butterfly Valve with Composition Seal

Valve Size (NPS)	Valve Shaft Diameter (inches)	A	B	C			Maximum Torque, (inch-pounds)	
				60°	75°	90°	Breakout $T_B$	Dynamic $T_D$
3	1/2	0.50	136	0.8	1.8	8	280	515
4	5/8	0.91	217	3.1	4.7	25	476	1225
6	3/4	1.97	403	30	24	70	965	2120
8	1	4.2	665	65	47	165	1860	4140
10	1-1/4	7.3	1012	125	90	310	3095	9820
12	1-1/2	11.4	1422	216	140	580	4670	12,000

#### 5.13.2.1 Maximum Rotation

Maximum rotation is defined as the angle of valve disk or ball in the fully open position.

Normally, maximum rotation is 90 degrees. The ball or disk rotates 90 degrees from the closed position to the wide open position.

Some of the pneumatic spring-return piston and pneumatic spring-and-diaphragm actuators are limited to 60 or

75 degrees rotation.

For pneumatic spring-and-diaphragm actuators, limiting maximum rotation allows for higher initial spring compression, resulting in more actuator breakout torque. Additionally, the effective length of each actuator lever changes with valve rotation. Published torques, particularly for pneumatic piston actuators, reflect this changing lever length. ■

## 5.14 Cavitation and Flashing

### 5.14.1 Choked Flow Causes Flashing and Cavitation

The IEC liquid sizing standard calculates a choked pressure drop,  $\Delta P_{\text{choked}}$ . If the actual pressure drop across the valve, as defined by the system conditions of  $P_1$  and  $P_2$ , is greater than  $\Delta P_{\text{choked}}$  then either flashing or cavitation may occur. Structural damage to the valve and adjacent piping may also result. Knowledge of what is actually happening within the valve will permit selection of a valve that can eliminate or reduce the effects of cavitation and flashing.

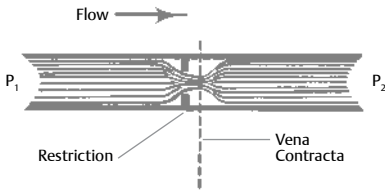

Figure 5.6 Vena Contracta Illustration

The physical phenomena label is used to describe flashing and cavitation because these conditions represent actual changes in the phase of the fluid media. The change is from the liquid state to the vapor state and results from the increase in fluid velocity at or just downstream of the greatest flow restriction, normally the valve port. As liquid flow passes through the restriction, there is a necking down, or contraction, of the flow stream. The minimum cross-sectional area of the flow stream occurs just downstream of the actual physical restriction at a point called the vena contracta, as shown in Figure 5.6.

To maintain a steady flow of liquid through the valve, the velocity must be greatest at the vena contracta, where cross-sectional area is the least. The increase in velocity (or kinetic energy) is accompanied by a substantial decrease

in pressure (or potential energy) at the vena contracta. Further downstream, as the fluid stream expands into a larger area, velocity decreases and pressure increases. However, downstream pressure never recovers completely to equal the pressure that existed upstream of the valve. The pressure differential ( $\Delta P$ ) that exists across the valve is a measure of the amount of energy that was dissipated in the valve. Figure 5.7 provides a pressure profile explaining the differing performance of a streamlined high-recovery valve, such as a ball valve, and a valve with lower recovery capabilities due to greater internal turbulence and dissipation of energy.

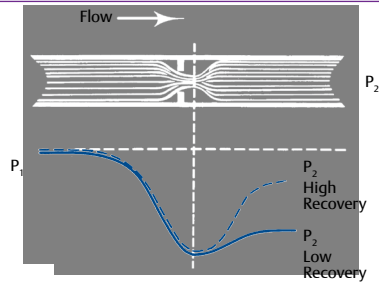

Figure 5.7 Comparison of Pressure Profiles for High- and Low-Recovery Valves

Regardless of the recovery characteristics of the valve, the pressure differential of interest pertaining to flashing and cavitation is the differential between the valve inlet and the vena contracta. If pressure at the vena contracta should drop below the vapor pressure of the fluid (due to increased fluid velocity at this point) bubbles will form in the flow stream. Formation of bubbles will increase greatly as vena contracta pressure drops further below the vapor pressure of the liquid. At this stage, there is no difference between flashing and cavitation, but the potential for structural damage to the valve definitely exists.

If pressure at the valve outlet remains below the vapor pressure of the

liquid, the bubbles will remain in the downstream system and the process is said to be flashing. Flashing can produce serious erosion damage to the valve trim parts and is characterized by a smooth, polished appearance of the eroded surface, as shown in Figure 5.8. Flashing is normally greatest at the point of highest velocity, which is usually at or near the seat line of the valve plug and seat ring.



Figure 5.8 Typical Appearance of Flashing Damage

On the other hand, if the downstream pressure is above the vapor pressure of the liquid, the bubbles will collapse, or implode, producing cavitation. Collapsing of the vapor bubbles releases energy and produces a noise similar to what one would expect if gravel were flowing through the valve. If the bubbles collapse in close proximity to solid surfaces in the valve, the energy released may tear away the material leaving a rough, cinderlike surface as shown in Figure 5.9. Cavitation damage may extend to the adjacent downstream pipeline, if that is where pressure recovery occurs and the bubbles collapse. High-recovery valves tend to be more subject to cavitation, since the vena contracta pressure is lower and more likely to reach down to the liquid's vapor pressure.

### 5.14.2 Valve Selection for Flashing Service

As shown in Figure 5.8, flashing damage is characterized by a smooth, polished appearance of the eroded surfaces. To review, flashing occurs because  $P_2$  is less than  $P_v$ .  $P_2$  is the pressure downstream of the valve and is a function of the downstream process and piping.  $P_v$  is a function of the fluid and operating temperature.

Therefore, the variables that define flashing are not directly controlled by the valve. This further means there is no way for any control valve to prevent flashing. Since flashing cannot be prevented by the valve the best solution is to select a valve with proper geometry and materials to avoid or minimize damage.

In general erosion is minimized by:

- Preventing or reducing the particle (liquid droplets in this case) impact with the valve surfaces
- Making those surfaces as hard as possible
- Lowering the velocity of the erosive flow

Selecting a valve with as few fluid directional changes as possible provides the least number of particle impacts. Sliding-stem angle valves are traditional solutions which provide such a flow path. Some rotary valves, such as eccentric rotary plug, and segmented ball valves, also offer straight-through flow paths. Valves with expanded flow areas downstream of the throttling point are beneficial because the erosive velocity is reduced. For those areas where the fluid must impact the valve surfaces, at the seating surfaces for example, choose materials that are as hard as possible. Generally the harder the material the longer it will resist erosion.

Fluids that are both flashing and corrosive can be especially troublesome.

Flashing water in a steel valve is an example of the synergistic result of both corrosion and erosion. The water causes corrosion of steel and the flashing causes erosion of the resultant, soft, oxide layer; these combine to create damage worse than either individual mechanism would. The solution in this case is to prevent the corrosion by selecting, as a minimum, a low-alloy steel.

### 5.14.3 Valve Selection for Cavitation Service

Cavitation damage is characterized by a rough, cinder-like appearance of the eroded surface as shown in Figure 5.9. It is distinctly different from the smooth, polished appearance caused by the erosion of flashing. The previous section describes how cavitation occurs when the vena contracta pressure is less than  $P_v$ , and  $P_2$  is greater than  $P_v$ . Cavitation can be treated by several means.



Figure 5.9 Typical Appearance of Cavitation Damage

The first is to eliminate the cavitation and thus the damage by managing the pressure drop. If the pressure drop across the valve can be controlled such that the local pressure never drops below the vapor pressure, then no vapor bubbles will form. Without vapor bubbles to collapse, there is no cavitation. To eliminate cavitation the total pressure drop across the valve is split, using multiple-stage trims, into smaller portions. Each of these small drops keeps its vena contracta pressure above the vapor pressure so no vapor

bubbles are formed.

The second method does not eliminate the cavitation but rather minimizes or isolates the damage much the same as with flashing solutions. This method aims to isolate the cavitation from valve surfaces and to harden those surfaces that the cavitation does impact.

A third method is to change the system in a manner to prevent the causes of cavitation. If the  $P_2$  can be raised enough so that the vena contracta pressure does not fall below the vapor pressure, that is the valve is no longer choked, then cavitation will be avoided.  $P_2$  can be raised by moving the valve to a location that has more static head on the downstream side. Applying an orifice plate or similar backpressure device can also raise  $P_2$  at the valve; the downside is the potential for the cavitation to transfer from the valve to the orifice plate. ■

## 5.15 Noise Prediction

### 5.15.1 Aerodynamic

Industry leaders use the International Electrotechnical Commission standard IEC 60534-8-3: Industrial-process control valves—Part 8: Noise Considerations—Section 3: Control valve aerodynamic noise prediction method. This method consists of a mix of thermodynamic and aerodynamic theory and empirical information. The design of the method allows a noise prediction for a valve based on the measurable geometry of the valve and the service conditions applied to the valve. The standard also allows valve vendors to use laboratory measured empirical data within the framework to provide more accurate predictions. Because of this analytical framework for valve noise prediction the IEC method allows an objective evaluation of alternatives.

The method describes two different noise sources that can contribute to the overall noise generated by the valve: trim noise and valve outlet noise. The trim noise is dependent on the type of trim and its geometric features. The valve outlet noise is dependent on the valve outlet area, valve outlet Mach number and any expander downstream of the valve.

The method defines five basic steps to a noise prediction. Where applicable, these steps need to be completed for both the trim and valve outlet noise sources and combined into a total valve noise level.

*1. Calculate the total stream power in the process at the vena contracta.*

The noise of interest is generated by the valve in and downstream of the vena contracta. If the total power dissipated by throttling at the vena contracta can be calculated, then the fraction that is noise power can be determined. Since power is the time rate of energy, a form of the familiar equation for calculating kinetic energy can be used. The kinetic energy equation is  $1/2 mv^2$  where  $m$  is mass and  $v$  is velocity. If the mass flow rate is substituted for the mass term, then the equation calculates the power. The velocity is the vena contracta velocity and is calculated with the energy equation of the First Law of Thermodynamics.

*2. Determine the fraction of total power that is acoustic power.*

The method considers the process conditions applied across the valve to determine the particular noise generating mechanism in the valve. There are five defined regimes dependent on the relationship of the vena contracta pressure and the downstream pressure. For each of these regimes an acoustic efficiency is defined and calculated. The standard also

allows laboratory measured acoustic efficiencies to replace the analytical estimations. This acoustic efficiency establishes the fraction of the total stream power, as calculated in Step 1, which is noise power. In designing a quiet valve, lower acoustic efficiency is one of the goals.

*3. Convert acoustic power to sound pressure spectrum.*

The final goal of the IEC prediction method is determination of the sound pressure level at a reference point outside the valve where human hearing is a concern. Step 2 delivers acoustic power, which is not directly measurable. Acoustic or sound pressure is measurable and therefore has become the default expression for noise in most situations. Converting from acoustic power to the overall sound pressure level uses basic acoustic theory.

To increase the accuracy of the noise prediction, the standard employs a frequency spectrum calculation. A sound pressure spectrum defines how much noise exists at each frequency in the audible range. This spectrum's shape can be determined from the valve geometry, flow conditions and an ideal characteristic spectrum given in the standard. The standard also allows a laboratory measured characteristic spectrum to be used.

*4. Account for the transmission loss of the pipe wall and restate the sound pressure spectrum at the outside surface of the pipe.*

Steps 1 through 3 are involved with the noise generation process inside the pipe. There are times when this is the area of interest, but the noise levels on the outside of the pipe are the prime requirement.

The method must account for the change in the noise as the reference

location moves from inside the pipe to outside the pipe. The pipe wall has physical characteristics, due to its material, size, and shape, that define how well the noise will transmit through the pipe. The fluid-borne noise inside the pipe must interact with the inside pipe wall to cause the pipe wall to vibrate, then the vibration must transmit through the pipe wall to the outside pipe wall, and there the outside pipe wall must interact with the atmosphere to generate sound waves. These three steps of noise transmission are dependent on the noise frequency. The method determines the pipe transmission loss as a function of frequency. The method then compares the internal noise spectrum and the transmission-loss spectrum to determine how much the external sound pressure spectrum will be attenuated by the pipe wall.

5. Account for distance and calculate the sound pressure level at the observer's location.

Step 4 delivers the external sound pressure level spectrum at the outside surface of the pipe wall. Again, basic acoustic theory is applied to calculate the sound pressure level at the observer's location. Sound power is constant for any given situation, but the associated sound pressure level varies with the area the power is spread over. As the observer moves farther away from the pipe wall, the total area the sound power is spread over increases. This causes the sound pressure level to decrease.

### 5.15.2 Hydrodynamic

Noticeable hydrodynamic noise is usually associated with cavitation. The traditional description of the sound is as rocks flowing inside the pipe. This association of hydrodynamic noise with cavitation is reflected in the various prediction methods available today.

The methods account for one noise characteristic for liquids in non-choked flow situations and another characteristic in choked, cavitating flow situations.

There are a variety of situations where the fluid is a two-phase mixture.

These include liquid-gas two-phase fluids at the inlet of the valve, flashing fluids, and fluids that demonstrate outgassing due to throttling. Noise prediction methods for these cases are not yet well established. Test results and field surveys of installed multi-phase systems indicate these noise levels do not contribute to overall plant noise levels or exceed worker exposure levels. ■



Figure 5.10 Valve Trim Design for Reducing Aerodynamic Noise

## 5.16 Noise Control

In closed systems (not vented to atmosphere), any noise produced in the process becomes airborne only by transmission through the valves and adjacent piping that contain the flowstream. The sound field in the flowstream forces these solid boundaries to vibrate. The vibrations cause disturbances in the ambient atmosphere that are propagated as sound waves.

Noise control employs either source treatment, path treatment, or both.





Figure 5.11 Valve and Inline Diffuser Combination

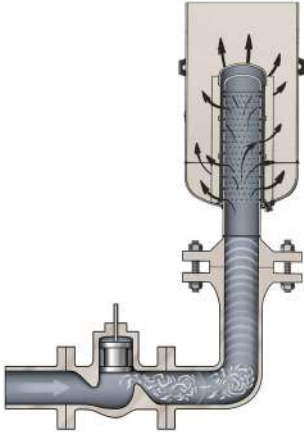

Figure 5.12 Valve and Vent Diffuser Combination

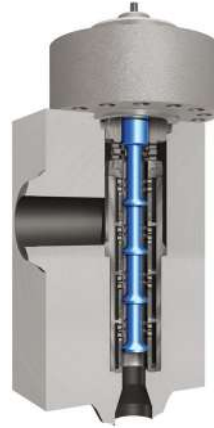

Figure 5.13 Special Valve Design to Eliminate Cavitation

Source treatment, preventing or attenuating noise at its source, is the most desirable approach, if economically and physically feasible.

Recommended cage-style source treatment approaches are depicted in Figure 5.10. The upper view shows a cage with many narrow parallel slots

designed to minimize turbulence and provide a favorable velocity distribution in the expansion area. This economical approach to quiet valve design can provide 15 to 20 dBA noise reduction with little or no decrease in flow capacity.

The lower view in Figure 5.10 shows a two-stage, cage-style trim designed

for optimum noise attenuation where pressure drop ratios ( $\Delta P/P_1$ ) are high.

To obtain the desired results, restrictions must be sized and spaced in the primary cage wall so that the noise generated by jet interaction is not greater than the summation of the noise generated by the individual jets.

This trim design can reduce the valve noise by as much as 30 dBA. The final design shown uses a combination of several noise reduction strategies to reduce valve noise up to 40 dBA. Those strategies are:

- Unique passage shape reduces the conversion of total stream power generated by the valve into noise power.
- Multistage pressure reduction divides the stream power between stages and further reduces the acoustic conversion efficiency.
- Frequency spectrum shifting reduces acoustic energy in the audible range by capitalizing on the transmission loss of the piping.
- Exit jet independence is maintained to avoid noise regeneration due to jet coalescence.
- Velocity management is accomplished with expanding areas to accommodate the expanding gas.
- Complementary body designs prevent flow impingement on the body wall and secondary noise sources.

For control valve applications operating at high pressure ratios ( $\Delta P/P_1 > 0.8$ ) the series restriction approach, splitting the total pressure drop between the control valve and a fixed restriction (diffuser) downstream of the valve can be effective in minimizing noise. To optimize the effectiveness of a diffuser, it must be designed (special shape and sizing) for each given installation so that the noise levels generated by the valve and diffuser are equal. Figure 5.11 shows

a typical installation.

Control systems venting to atmosphere are generally very noisy because of the high pressure ratios and high exit velocities involved. Dividing the total pressure drop between the actual vent and an upstream control valve, by means of a vent diffuser, quiets both the valve and the vent. A properly sized vent diffuser and valve combination, such as that shown in Figure 5.12, can reduce the overall system noise level as much as 40 dBA.

Source treatment for noise problems associated with control valves handling liquid is directed primarily at eliminating or minimizing cavitation. Because flow conditions that will produce cavitation can be accurately predicted, valve noise resulting from cavitation can be eliminated by application of appropriate limits to the service conditions at the valve by use of break-down orifices, valves in series, etc. Another approach to source treatment is using special valve trim that uses the series restriction concept to eliminate cavitation as shown in Figure 5.13.

A second approach to noise control is that of path treatment. The fluid stream is an excellent noise transmission path. Path treatment consists of increasing the impedance of the transmission path to reduce the acoustic energy communicated to the receiver.

Dissipation of acoustic energy by use of acoustical absorbent materials is one of the most effective methods of path treatment. Whenever possible the acoustical material should be located in the flow stream either at or immediately downstream of the noise source. In gas systems, inline silencers effectively dissipate the noise within the fluid stream and attenuate the noise level transmitted to the solid boundaries. Where high-mass flow rates and/or high pressure

ratios across the valve exist, inline silencers, such as that shown in Figure 5.14, are often the most realistic and economical approach to noise control. Use of absorption-type inline silencers can provide almost any degree of attenuation desired. However, economic considerations generally limit the insertion loss to approximately 25 dBA.



Figure 5.14 Typical Inline Silencer

Noise that cannot be eliminated within the boundaries of the flow stream must be eliminated by external treatment. This approach to the abatement of control valve noise suggests the use of heavy walled piping, acoustical insulation of the exposed solid boundaries of the fluid stream, use of insulated boxes, buildings, etc., to isolate the noise source.

Path treatment such as heavy wall pipe or external acoustical insulation can be an economical and effective technique for localized noise abatement. However, noise is propagated for long distances via the fluid stream and the effectiveness of the heavy wall pipe or external insulation ends where the treatment ends. ■

## 5.17 Noise Summary

The amount of noise that will be generated by a proposed control valve installation can be quickly and reasonably predicted by use of industry standard methods. These methods are available in computer software for ease of use. Such sizing and noise prediction tools help in the proper selection of noise reduction equipment

such as shown in Figures 5.15 and 5.16. Process facility requirements for low environmental impact will continue to drive the need for quieter control valves. The prediction technologies and valve designs that deliver this are always being improved. For the latest in either equipment or prediction technology, contact the valve manufacturer's representative. ■



Figure 5.15 Globe-Style Valve with Noise Abatement Cage for Aerodynamic Flow



Figure 5.16 Ball-Style Valve with Attenuator to Reduce Hydrodynamic Noise

## 5.18 Packing Selection

The following tables and Figures 5.17 and 5.18 offer packing selection guidelines for sliding-stem and rotary valves.

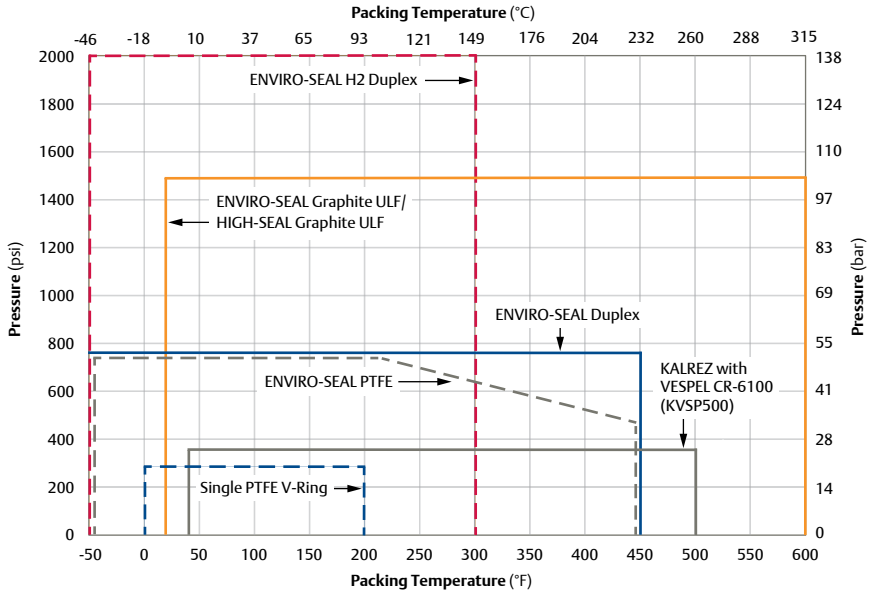

Figure 5.17 Application Guidelines Chart for 100 PPM Service

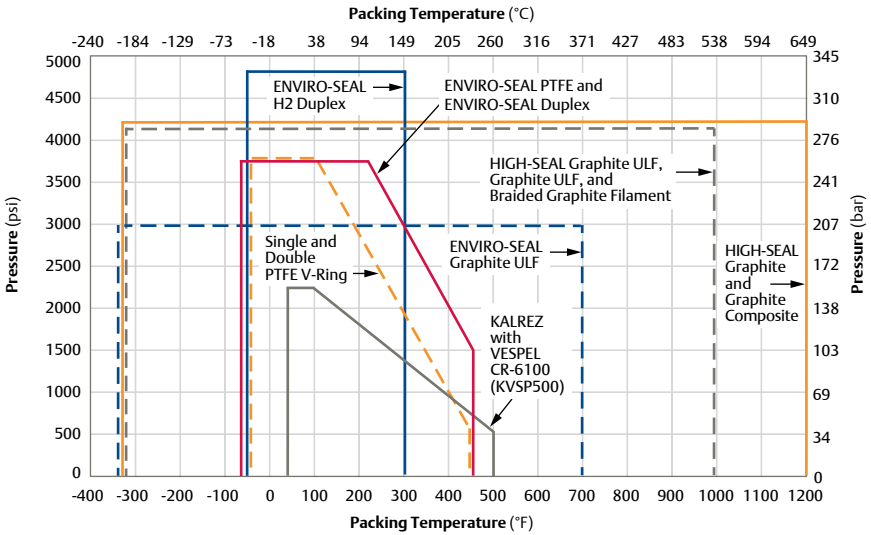

Figure 5.18 Application Guidelines Chart for Non-Environmental Service

### 5.18.1 Packing Selection Guidelines for Sliding-Stem Valves

Packing System	Maximum Pressure and Temperature Limits for 100 PPM Service <sup>(1)</sup>		Application Guideline for Non-Environmental Service <sup>(1)</sup>	
	Metric	Imperial	Metric	Imperial
Single PTFE V-Ring	20.7 bar -18 to 93°C	300 psi 0 to 200°F	See Figure 5.15 -46 to 232°C	See Figure 5.15 -50 to 450°F
Double PTFE V-Ring	---	---	See Figure 5.15 -46 to 232°C	See Figure 5.15 -50 to 450°F
ENVIRO-SEAL PTFE	See Figure 5.14 -46 to 232°C	See Figure 5.14 -50 to 450°F	See Figure 5.15 -46 to 232°C	See Figure 5.15 -50 to 450°F
ENVIRO-SEAL Duplex	51.7 bar -46 to 232°C	750 psi -50 to 450°F	See Figure 5.15 -46 to 232°C	See Figure 5.15 -50 to 450°F
ENVIRO-SEAL H2 Duplex	138 bar -46 to 149°C	2000 psi -50 to 300°F	330 bar -46 to 149°C	4800 psi -50 to 300°F
KALREZ® with Vespel® CR-6100 (K-VSP 500) <sup>(3)</sup>	24.1 bar 4 to 260°C	350 psig 40 to 500°F	See Figure 5.15 -40 to 260°C	See Figure 5.15 -40 to 500°F
ENVIRO-SEAL Graphite ULF	103 bar -7 to 315°C	1500 psi 20 to 600°F	207 bar -198 to 371°C	3000 psi -325 to 700°F
HIGH-SEAL Graphite ULF	103 bar -7 to 315°C	1500 psi 20 to 600°F	290 bar <sup>(4)</sup> -198 to 538°C	4200 psi <sup>(4)</sup> -325 to 1000°F
Graphite Composite / HIGH-SEAL Graphite	---	---	290 bar <sup>(4)</sup> -198 to 649°C	4200 psi <sup>(4)</sup> -325 to 1200°F
Braided Graphite Filament	---	---	290 bar -198 to 538°C <sup>(5)</sup>	4200 psi -325 to 1000°F <sup>(5)</sup>
Graphite ULF	---	---	290 bar -198 to 538°C	4200 psi -325 to 1000°F

1. The values shown are only guidelines. These guidelines can be exceeded, but shortened packing life or increased leakage might result. The temperature ratings apply to the actual packing temperature, not to the process temperature.

2. See Fisher Catalog 14 for actual friction values.

3. The KALREZ pressure/temperature limits referenced in this bulletin are for Fisher valve applications only. DuPont may claim higher limits.

4. Except for the 9.5 mm (3/8 inch) stem, 110 bar (1600 psi).

5. Except for oxidizing service, -198 to 371°C (-325 to 700°F).

## Packing Selection Guidelines for Sliding-Stem Valves continued...

Packing System	Seal Performance Index	Service Life Index	Packing Friction <sup>(2)</sup>
Single PTFE V-Ring	Better	Long	Very low
Double PTFE V Ring	Better	Long	Low
ENVIRO-SEAL PTFE	Best	Very long	Low
ENVIRO-SEAL Duplex	Best	Very long	Low
ENVIRO-SEAL H2 Duplex	Best	Very long	Medium
KALREZ with Vespel CR 6100 (K- VSP 500) <sup>(3)</sup>	Best	Long	Low
ENVIRO-SEAL Graphite ULF	Best	Very long	Medium
HIGH-SEAL Graphite ULF	Best	Very long	Medium
Graphite Composite / HIGH-SEAL Graphite	Better	Very long	Very high
Braided Graphite Filament	Good	Moderate	High
Graphite ULF	Better	Very long	Medium

1. The values shown are only guidelines. These guidelines can be exceeded, but shortened packing life or increased leakage might result. The temperature ratings apply to the actual packing temperature, not to the process temperature.

2. See Fisher Catalog 14 for actual friction values.

3. The KALREZ pressure/temperature limits referenced in this bulletin are for Fisher valve applications only. DuPont may claim higher limits.

4. Except for the 9.5 mm (3/8 inch) stem, 110 bar (1600 psi).

5. Except for oxidizing service, -198 to 371°C (-325 to 700°F).

## 5.18.2 Packing Selection Guidelines for Rotary Valves

Packing System	Maximum Pressure and Temperature Limits for 100 PPM Service <sup>(1)</sup>		Application Guideline for Non-Environmental Service <sup>(1)</sup>	
	Metric	Customary U.S.	Metric	Customary U.S.
Single PTFE V-Ring	---	---	103 bar -46 to 232°C	1500 psig -50 to 450°F
ENVIRO-SEAL PTFE	103 bar -46 to 232°C	1500 psig -50 to 450°F	207 bar -46 to 232°C	3000 psig -50 to 450°F
Live-Loaded PTFE for V250 Valves	69 bar -29 to 93°C	1000 psig -20 to 200°F	155 bar -46 to 232°C	2250 psig -50 to 450°F
KALREZ with Vespel CR 6100 (KVSP 500) <sup>(3)</sup>	24.1 bar 4 to 260°C	350 psig 40 to 500°F	51 bar -40 to 260°C	750 psig -40 to 500°F
ENVIRO-SEAL Graphite	103 bar -7 to 315°C	1500 psig 20 to 600°F	207 bar -198 to 371°C	3000 psig -325 to 700°F
Graphite Ribbon	---	---	103 bar -198 to 538°C <sup>(2)</sup>	1500 psig -325 to 1000°F <sup>(2)</sup>

1. The values shown are only guidelines. These guidelines can be exceeded, but shortened packing life or increased leakage might result. The temperature ratings apply to the actual packing temperature, not to the process temperature.

2. Except for oxidizing service, -198 to 371°C (-325 to 700°F).

3. The KALREZ pressure/temperature limits referenced in this bulletin are for Fisher valve applications only. DuPont may claim higher limits.

*Packing Selection Guidelines for Rotary Valves continued...*

Packing System	Seal Performance Index	Service Life Index	Packing Friction
Single PTFE V-Ring	Better	Long	Very low
ENVIRO-SEAL PTFE	Excellent	Very long	Low
Live-Loaded PTFE for V250 Valves	Excellent	Very long	Low
KALREZ with Vespel CR-6100 (KVSP 500) <sup>(3)</sup>	Excellent	Long	Very low
ENVIRO-SEAL Graphite	Excellent	Very long	Moderate
Graphite Ribbon	Acceptable	Acceptable	High

1. The values shown are only guidelines. These guidelines can be exceeded, but shortened packing life or increased leakage might result. The temperature ratings apply to the actual packing temperature, not to the process temperature.

2. Except for oxidizing service, -198 to 371°C (-325 to 700°F).

3. The KALREZ pressure/temperature limits referenced in this bulletin are for Fisher valve applications only. DuPont may claim higher limits.

## 5.19 Valve Body Materials

Body material selection is usually based on the pressure, temperature, corrosive properties, and erosive properties of the flow media. Sometimes a compromise must be reached in selecting a material. For instance, a material with good erosion resistance may not be satisfactory because of poor corrosion resistance when handling a particular fluid.

Some service conditions require use of exotic alloys and metals to withstand particular corrosive properties of the flowing fluid. These materials are much more expensive than common metals, so economy may also be a factor in material selection. Fortunately, the majority of control valve applications handle relatively non-corrosive fluids at reasonable pressures and temperatures. Therefore, cast carbon steel is the most commonly used valve body material and can provide satisfactory service at much lower cost than the exotic alloy materials.

Specifications have been developed for ordering highly corrosion-resistant, high-alloy castings. These specifications represent solutions to problems

encountered with some of those alloys. These problems included unacceptable corrosion resistance compared to the wrought materials, weldability issues, and unacceptable lead times. These alloys are also difficult to cast. The specifications include a foundry qualification process, dedicated pattern equipment, pattern alloy qualification, heat qualification, and detailed controls on raw material, visual inspection, weld repairs, heat treatment, and non-destructive testing. Designations for these exotic and common grades are included in Table 5.36 Designations for Common Valve Body Materials.

The following descriptions and tables provide basic information on various popular casting grades used for control valve bodies. ASTM material designations are included. Use of proper ASTM designations is considered good practice and is encouraged in specifying materials, particularly for pressure-containing parts. Additional engineering data on these and other materials is included in Chapter 13.

**Cast Carbon Steel (ASTM A216 Grade WCC)**—WCC is the most popular cast steel material used for valve bodies in moderate services such as air, saturated or superheated steam, non-corrosive liquids and gases. WCC is not used above 425°C (800°F) as the carbon rich phase might be converted to graphite. It is generally welded without post weld heat treatment unless nominal thickness exceeds 1-1/4 inches (32 mm). Major weld repairs always receive post weld heat treatment.

**Cast Chromium-Molybdenum Steel (ASTM A217 Grade WC9)**—This is the standard cast Cr-Mo grade. WC9 has replaced C5 as the standard because of superior casting and welding properties. WC9 has successfully replaced C5 in most applications, especially in steam and boiler feedwater service. The chromium and molybdenum provide erosion-corrosion and creep resistance, making it useful to 595°C (1100°F). WC9 is generally heat treated after welding. Major weld repairs always receive postweld heat treatment.

**Cast Type 304L Stainless Steel (ASTM A351 Grade CF3)**— This is a common material offering for chemical service valves. Cast 304L is often preferred for nitric acid and certain other chemical service applications. Optimum corrosion resistance is retained even in the as-welded condition when proper welding procedures are used. CF3 is not rated for pressure boundary parts above 425°C (800°F).

**Cast Type 316 Stainless Steel (ASTM A351 Grade CF8M)**—This is the industry standard stainless steel cast body material. The addition of molybdenum gives Type 316 greater resistance to corrosion, pitting, creep, and oxidizing fluids compared to 304 or 304L. It has the widest temperature range of any standard material: -254°C (-425°F) to 816°C (1500°F). The castings are heat treated to provide maximum corrosion resistance. At temperatures above 538°C (1000°F) the carbon content shall be 0.04% minimum.

**Cast Type 317 Stainless Steel (ASTM A351 Grade CG8M)**—S31700 is essentially S31600 with the nickel and molybdenum contents increased 1% each. This affords greater resistance to pitting than is obtained with S31600.

Like S31600, S31700 is completely austenitic and non-magnetic. Because its strength is similar to that of S31600, it has the same pressure-temperature ratings. CG8M is the casting version of S31700. It contains considerable amounts of ferrite (15 to 35%), and is, therefore, partially strongly magnetic. In general, Type S31700 has better corrosion resistance than S31600 in certain environments because of its higher molybdenum content. It has good corrosion resistance in many applications such as digester liquor, dry chlorine dioxide and many other pulp and paper environments. For CG8M, the maximum temperature for pressure-retaining parts is 538°C (1000°F). ■



### 5.19.1 Designations for Common Valve Body Materials

Casting Designations	Generic Designations	UNS Numbers for Wrought Equivalents
CD3MN	Standard duplex	S31803, S32205
CD3MWCuN	Super duplex	S32760
CF3	304L	S30403
CF8	304	S30400
CF3M	316L	S31603
CF8M	316	S31600
CG3M	317L	S31703
CG8M	317	S31700
CK3MCuN	Alloy 254 SMO	S31254
CN7M	Alloy 20Cb3	N08020
CU5MCuC	Alloy 825	N08825
CW12MW	Obsolete Alloy C	N10002
CW2M	Alloy C	N10276, N06455
CX2MW	Alloy C22	N06022
CW6MC	Alloy 625	N06625
CX2M	Alloy 59	N06059
CY40	Alloy 600	N06600
CZ100	Nickel Alloy 200	N02200
LCB	LCB	J03003
LCC	LCC	J02505
M35-1	Alloy 400	N04400
N12MV	Alloy B	N10001
N7M	Alloy B2	N10665
WCB	WCB	J03002
WCC	WCC	J02503
Titanium C3	C3	R50550
Zirconium 702C	702C	R60702
Zirconium 705C	705C	R60705

## 5.20 Pressure-Temperature Ratings

### 5.20.1 Pressure-Temperature Ratings for Standard Class ASTM A216 Grade WCC Cast Valves

(In Accordance with ASME B16.34-2013)

Temperature	Working Pressures by Class				
	150	300	600	900	1500
°C	Bar				
-29 to 38	19.8	51.7	103.4	155.1	258.6
50	19.5	51.7	103.4	155.1	258.6
100	17.7	51.5	103.0	154.6	257.6
150	15.8	50.2	100.3	150.5	250.8
200	13.8	48.6	97.2	145.8	243.2
250	12.1	46.3	92.7	139.0	231.8
325	9.3	41.4	82.6	124.0	206.6
350	8.4	40.0	80.0	120.1	200.1
375	7.4	37.8	75.7	113.5	189.2
400	6.5	34.7	69.4	104.2	173.6
425	5.5	28.8	57.5	86.3	143.8
°F	psig				
-20 to 100	290	750	1,500	2,250	3,750
200	260	750	1,500	2,250	3,750
300	230	730	1,455	2,185	3,640
400	200	705	1,405	2,110	3,520
500	170	665	1,330	1,995	3,325
600	140	605	1,210	1,815	3,025
650	125	590	1,175	1,765	2,940
700	110	555	1,110	1,665	2,775
750	95	505	1,015	1,520	2,535
800	80	410	825	1,235	2,055

## 5.20.2 Pressure-Temperature Ratings for Standard Class ASTM A217 Grade WC9 Cast Valves

(In Accordance with ASME B16.34-2013)

Temperature	Working Pressures by Class				
	150	300	600	900	1500
°C	Bar				
-29 to 38	19.8	51.7	103.4	155.1	258.6
50	19.5	51.7	103.4	155.1	258.6
100	17.7	51.5	103.0	154.6	257.6
150	15.8	50.3	100.3	150.6	250.8
200	13.8	48.6	97.2	145.8	243.4
250	12.1	46.3	92.7	139.0	321.8
300	10.2	42.9	85.7	128.6	214.4
325	9.3	41.4	82.6	124.0	206.6
350	8.4	40.3	80.4	120.7	201.1
375	7.4	38.9	77.6	116.5	194.1
400	6.5	36.5	73.3	109.8	183.1
425	5.5	35.2	70.0	105.1	175.1
450	4.6	33.7	67.7	101.4	169.0
475	3.7	31.7	63.4	95.1	158.2
500	2.8	28.2	56.5	84.7	140.9
538	1.4	18.4	36.9	55.3	92.2
°F	psig				
-20 to 100	290	750	1,500	2,250	3,750
200	260	750	1,500	2,250	3,750
300	230	730	1,455	2,185	3,640
400	200	705	1,410	2,115	3,530
500	170	665	1,330	1,995	3,325
600	140	605	1,210	1,815	3,025
650	125	590	1,175	1,765	2,940
700	110	570	1,135	1,705	2,840
750	95	530	1,065	1,595	2,660
800	80	510	1,015	1,525	2,540
850	65	485	975	1,460	2,435
900	50	450	900	1,350	2,245
950	35	385	755	1,160	1,930
1000	20	265	535	800	1,335
1050	20 <sup>(1)</sup>	175	350	525	875
1100	20 <sup>(1)</sup>	110	220	330	550

1. Flanged end ratings terminate at 538°C (1000°F)

### 5.20.3 Pressure-Temperature Ratings for Standard Class ASTM A351 Grade CF3 Cast Valves

(In Accordance with ASME B16.34-2013)

Temperature	Working Pressures by Class				
	150	300	600	900	1500
°C	Bar				
-29 to 38	19.0	49.6	99.3	148.9	248.2
50	18.3	47.8	95.6	143.5	239.1
100	15.7	40.9	81.7	122.6	204.3
150	14.2	37.0	74.0	111.0	185.0
200	13.2	34.5	69.0	103.4	172.4
250	12.1	32.5	65.0	97.5	162.4
325	9.3	30.2	60.4	90.7	151.1
350	8.4	29.6	59.3	88.9	148.1
375	7.4	29.0	58.1	87.1	145.2
400	6.5	28.4	56.9	85.3	142.2
425	5.5	28.0	56.0	84.0	140.0
°F	psig				
-20 to 100	275	720	1,440	2,160	3,600
200	230	600	1,200	1,800	3,000
300	205	540	1,075	1,615	2,690
400	190	495	995	1,490	2,485
500	170	465	930	1,395	2,330
600	140	440	885	1,325	2,210
650	125	430	865	1,295	2,160
700	110	420	845	1,265	2,110
750	95	415	825	1,240	2,065
800	80	405	810	1,215	2,030

### 5.20.4 Pressure-Temperature Ratings for Standard Class ASTM A351 Grades CF8M and CG8M<sup>(1)</sup> Valves

(In Accordance with ASME B16.34-2013)

Temperature	Working Pressures by Class				
	150	300	600	900	1500
°C	Bar				
-29 to 38	19.0	49.6	99.3	148.9	248.2
50	18.4	48.1	96.2	144.3	240.6
100	16.2	42.2	84.4	126.6	211.0
150	14.8	38.5	77.0	115.5	192.5
200	13.7	35.7	71.3	107.0	178.3
250	12.1	33.4	66.8	100.1	166.9
300	10.2	31.6	63.2	94.9	158.1
325	9.3	30.9	61.8	92.7	154.4
350	8.4	30.3	60.7	91.0	151.6
375	7.4	29.9	59.8	89.6	149.4
400	6.5	29.4	58.9	88.3	147.2
425	5.5	29.1	58.3	87.4	145.7
450	4.6	28.8	57.7	86.5	144.2
475	3.7	28.7	57.3	86.0	143.4
500	2.8	28.2	56.5	84.7	140.9
538	1.4	25.2	50.0	75.2	125.5
550	1.4 <sup>(2)</sup>	25.0	49.8	74.8	124.9
575	1.4 <sup>(2)</sup>	24.0	47.9	71.8	119.7
600	1.4 <sup>(2)</sup>	19.9	39.8	59.7	99.5
625	1.4 <sup>(2)</sup>	15.8	31.6	47.4	79.1
650	1.4 <sup>(2)</sup>	12.7	25.3	38.0	63.3
675	1.4 <sup>(2)</sup>	10.3	20.6	31.0	51.6
700	1.4 <sup>(2)</sup>	8.4	16.8	25.1	41.9
725	1.4 <sup>(2)</sup>	7.0	14.0	21.0	34.9
750	1.4 <sup>(2)</sup>	5.9	11.7	17.6	29.3
775	1.4 <sup>(2)</sup>	4.6	9.0	13.7	22.8
800	1.2 <sup>(2)</sup>	3.5	7.0	10.5	17.4
816	1.0 <sup>(2)</sup>	2.8	5.9	8.6	14.1

*Pressure-Temperature Ratings for Standard Class ASTM A351 Grades CF8M and CG8M<sup>(1)</sup>  
Valves continued...*

Temperature	Working Pressures by Class				
	150	300	600	900	1500
°F	psig				
-20 to 100	275	720	1,440	2,160	3,600
200	235	620	1,240	1,860	3,095
300	215	560	1,120	1,680	2,795
400	195	515	1,025	1,540	2,570
500	170	480	955	1,435	2,390
600	140	450	900	1,355	2,255
650	125	440	885	1,325	2,210
700	110	435	870	1,305	2,170
750	95	425	855	1,280	2,135
800	80	420	845	1,265	2,110
850	65	420	835	1,255	2,090
900	50	415	830	1,245	2,075
950	35	385	775	1,160	1,930
1000	20	365	725	1,090	1,820
1050	20	360	720	1,080	1,800
1100	20 <sup>(2)</sup>	305	610	915	1,525
1150	20 <sup>(2)</sup>	235	475	710	1,185
1200	20 <sup>(2)</sup>	185	370	555	925
1250	20 <sup>(2)</sup>	145	295	440	735
1300	20 <sup>(2)</sup>	115	235	350	585
1350	20 <sup>(2)</sup>	95	190	290	480
1400	20 <sup>(2)</sup>	75	150	225	380
1450	20 <sup>(2)</sup>	60	115	175	290
1500	15 <sup>(2)</sup>	40	85	125	205

1. CG8M is limited to 538°C (1000°F).

2. Flanged end ratings terminate at 538°C (1000°F) for CF8M.

## 5.21 Non-Metallic Material Abbreviations

ASTM Designations and Tradenames	Generic Description
CR	Chloroprene
EPDM	Ethylene propylene terpolymer
FFKM, Kalrez <sup>(1)</sup> , Chemraz <sup>(2)</sup>	Perfluoroelastomer
FKM, Viton <sup>(1)</sup>	Fluoroelastomer
FVMQ	Fluorosilicone
NBR	Nitrile
NR	Natural rubber
PUR	Polyurethane
VMQ	Silicone
PEEK	Polyetheretherketone
PTFE	Polytetrafluoroethylene
PTFE, Carbon Filled	Polytetrafluoroethylene, Carbon Filled
PTFE, Glass Filled	Polytetrafluoroethylene, Glass Filled
TCM Plus <sup>(3)</sup>	Mineral and MoS <sup>2</sup> filled PTFE
TCM Ultra <sup>(3)</sup>	PEEK and MoS <sup>2</sup> filled PTFE
Composition Gasket	Composite Gasket
Flexible Graphite, Grafoil <sup>(4)</sup>	Flexible Graphite

1. Registered trademark of DuPont Performance Elastomers.  
 2. Trademark of Greene, Tweed & Co.  
 3. Trademark of Fisher Controls International LLC.  
 4. Trademark of GrafTech Intl.

## 5.22 Non-Destructive Test Procedures

Successful completion of specific non-destructive examinations is required for valves intended for nuclear service and may be required by codes or customers in non-nuclear applications, particularly in the power industry.

Also, successful completion of the examinations may permit uprating of ASME Standard Class butt welded-end valves to a Special Class rating. The Special Class rating permits use of the butt welded-end valves at higher pressures than allowed for Standard Class valves. Procedures required for uprating to the Special Class are detailed in ASME Standard B16.34.

While it is not feasible to present complete details of code requirements for non-destructive examinations, this

book will summarize the principles and procedures of four major types of non-destructive examinations defined in ANSI, ASME, and ASTM standards.

### 5.22.1 Magnetic Particle (Surface) Examination

Magnetic particle examination can be used only on materials which can be magnetized. The principle includes application of a direct current across a piece to induce a magnetic field in the piece. Surface or shallow subsurface defects distort the magnetic field to the extent that a secondary magnetic field develops around the defect. If a magnetic powder, either dry or suspended in liquid, is spread over the magnetized piece, areas of distorted magnetic field will be visible, revealing an indication in the piece in the area of distortion. After de-magnetizing the

piece by reversing the electric current, it may be possible to weld repair the indication or it may be necessary to replace the piece. After repair or replacement, the magnetic particle examination must be repeated.

### **5.22.2 Liquid Penetrant (Surface) Examination**

This examination method permits detection of surface indications not visible to the naked eye. The surface to be examined is cleaned thoroughly and dried. The liquid penetrant dye, either water washable or solvent removable, is applied by dipping, brushing, or spraying, and allowed time to penetrate. Excess penetrant is washed or wiped off (depending on the penetrant used). The surface is again thoroughly dried and a developer (liquid or powder) is applied. Inspection is performed under the applicable light source. (Depending on the penetrant, some developers require use of an ultraviolet or black light to expose defective areas). If defects are discovered and repaired by welding, the piece must be re-examined after repair.

### **5.22.3 Radiographic (Volumetric) Examination**

Radiography of control valve parts works on the principle that X-rays and gamma rays will pass through metal objects which are impervious to visible light and will expose photographic film or digital X-ray sensors. The number and intensity of the rays passing through the metal object depend on the density of the material. Sub-surface defects represent changes in density of the material and can therefore be detected radiographically. The piece to be inspected is placed between the X-ray or gamma ray source and the photographic film or digital X-ray sensors. Detail and contrast sensitivity are determined by radiographing one or more small flat

plates of specified thickness at the same time the test subject is exposed. The small flat plate, called a penetrometer, has several holes of specified diameters drilled in it. Its image on the exposed film or digital image, along with the valve body or other test subject, makes it possible to determine the detail and contrast sensitivity of the radiograph.

Radiography can detect such casting defects as gas and blowholes, sand inclusions, internal shrinkage, cracks, hot tears, and slag inclusions. In castings for nuclear service, some defects such as cracks and hot tears are expressly forbidden and cannot be repaired. The judgment and experience of the radiographers is important because they must compare the radiograph with the acceptance criteria (ASTM reference radiographs) to determine the adequacy of the casting. When weld repairs are required, the casting must be radiographed again after the repair.

### **5.22.4 Ultrasonic (Volumetric) Examination**

This method monitors sound wave reflections from the piece being inspected to determine the depth and size of any indications. Ultrasonic examination can detect foreign materials and discontinuities in fine-grained metal and thus lends itself to volumetric examination of structures such as plate, bar, and forgings. The test is normally conducted either with a special oil called a couplant or underwater to ensure efficient transmission of sound waves. The sound waves are generated by a crystal probe and are reflected at each interface in the piece being tested, that is, at each outer face of the piece itself and at each face of the damaged or malformed internal portion. These reflections are received by the crystal probe and displayed on a screen to reveal the location and severity of the indication. ■





# Chapter 6

## Special Control Valves



As discussed in previous chapters, standard control valves can handle a wide range of control applications. The range of standard applications can be defined as being encompassed by: atmospheric pressure and 414 bar (6000 psig),  $-101^{\circ}\text{C}$  ( $-150^{\circ}\text{F}$ ) and  $232^{\circ}\text{C}$  ( $450^{\circ}\text{F}$ ), flow coefficient  $C_v$  values of 1.0 and 25000, and the limits imposed by common industrial standards. Certainly, corrosiveness and viscosity of the fluid, leakage rates, and many other factors demand consideration even for standard applications. Perhaps the need for careful consideration of valve selection becomes more critical for applications outside the standard limits mentioned above.

This chapter discusses some special applications and control valve modifications useful in controlling them, designs and materials for severe service, and test requirements useful for control valves used in nuclear power plant service.

## 6.1 High-Capacity Control Valves

Generally, globe-style valves larger than NPS 12, ball valves over NPS 24, and high-performance butterfly valves larger than NPS 48 fall in the special valve category. As valve sizes increase arithmetically, static pressure loads at shutoff increase geometrically. Consequently, shaft strength, bearing loads, unbalance forces, and available actuator thrust all become more significant with increasing valve size. Normally maximum allowable pressure drop is reduced on large valves to keep design and actuator requirements within reasonable limits. Even with lowered working pressure ratings, the flow capacity of some large-flow valves remains tremendous.

Noise levels must be carefully considered in all large-flow installations

because sound pressure levels increase in direct proportion to flow magnitude. To keep valve-originated noise within tolerable limits, large cast or fabricated valve body designs (Figure 6.1) have been developed. These bodies, normally cage-style construction, use unusually long valve plug travel, a great number of small flow openings through the wall of the cage, and an expanded outlet line connection to minimize noise output and reduce fluid velocity.



Figure 6.1 Large-Flow Valve Body for Noise Attenuation

Naturally, actuator requirements are severe, and long-stroke, double-acting pneumatic pistons are typically specified for large-flow applications. The physical size and weight of the valve and actuator components complicate installation and maintenance procedures. Installation of the valve body assembly into the pipeline and removal and replacement of major trim parts require heavy-duty hoists.

Maintenance personnel must follow the manufacturers' instruction manuals closely to minimize risk of injury. ■

## 6.2 Low-Flow Control Valves



Figure 6.2 Special Control Valve Designed for Very Low Flow Rates

Many applications exist in laboratories and pilot plants in addition to the general processing industries where control of extremely low flow rates is required. These applications are commonly handled in one of two ways. First, special trims are often available in standard control valve bodies. The special trim is typically made up of a seat ring and valve plug that have been designed and machined to very close tolerances to allow accurate control of very small flows. These types of constructions can often handle flow coefficients as low as 0.03. Using these special trims in standard control valves provides economy by reducing the need for spare parts inventory for special valves and actuators. Using this approach also makes future flow expansions easy by simply replacing the trim components in the standard control

valve body.

Control valves specifically designed for very low flow rates (Figure 6.2) also handle these applications. These valves often handle flow coefficients as low as 0.000001. In addition to the very low flows, these specialty control valves are compact and lightweight because they are often used in laboratory environments where very light schedule piping/tubing is used. These types of control valves are specially designed for the accurate control of very low flowing liquid or gaseous fluid applications. ■

## 6.3 High-Temperature Control Valves

Control valves for service at temperatures above 232°C (450°F) must be designed and specified with the temperature conditions in mind. At elevated temperatures, such as may be encountered in boiler feedwater systems and superheater bypass systems, the standard materials of control valve construction might be inadequate. For instance, plastics, elastomers, and standard gaskets generally prove unsuitable and must be replaced by more durable materials. Metal-to-metal seating materials are always used. Semi-metallic or laminated flexible graphite packing materials are commonly used, and spiral-wound stainless steel and flexible graphite gaskets are necessary.

Cr-Mo steels are often used for the valve body castings for temperatures above 538°C (1000°F). ASTM A217 Grade WC9 is used up to 593°C (1100°F). For temperatures on up to 816°C (1500°F) the material usually selected is ASTM A351 Grade CF8M, Type 316 stainless steel. For temperatures between 538°C (1000°F) and 816°C (1500°F), the carbon content must be controlled to the upper end of the range, 0.04 to 0.08%. The

9%Cr–1%Mo–V materials, such as ASTM A217 grade C12a castings and ASTM A182 grade F91 forgings are used at temperatures up to 650°C (1200°F).

Extension bonnets help protect packing box parts from extremely high temperatures. Typical trim materials include cobalt-based alloy 6, 316 with alloy 6 hardfacing, and nitrided 422 SST. ■

## 6.4 Cryogenic Service Valves

Cryogenics is the science dealing with materials and processes at temperatures below -101°C (150°F). For control valve applications in cryogenic services, many of the same issues need consideration as with high-temperature control valves. Plastic and elastomeric components often cease to function appropriately at temperatures below -18°C (0°F). In these temperature ranges, components such as packing and plug seals require special consideration. For plug seals, a standard soft seal will become very hard and less pliable thus not providing the shutoff required from a soft seat. Special elastomers have been applied in these temperatures but require special loading to achieve a tight seal.

Packing is a concern in cryogenic applications because of the frost that may form on valves in cryogenic applications. Moisture from the atmosphere condensates on colder surfaces and where the temperature of the surface is below freezing, the moisture will freeze into a layer of frost. As this frost and ice forms on the bonnet and stem areas of control valves and as the stem is stroked by the actuator, the layer of frost on the stem is drawn through the packing causing tears and thus loss of seal. The solution is to use extension bonnets (Figure 6.3) that allow the packing box area of the control valve to be warmed by ambient temperatures, thus preventing frost from forming on

the stem and packing box areas. The length of the extension bonnet depends on the application temperature and insulation requirements. The colder the application, the longer the extension bonnet required.

Materials of construction for cryogenic applications are generally CF8M body and bonnet material with 300 series stainless steel trim material. In flashing applications, hard facing might be required to combat erosion. ■

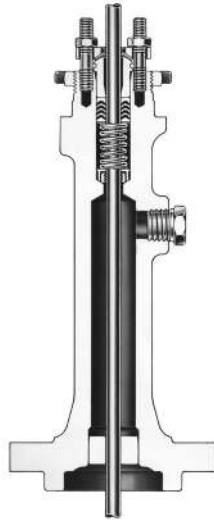

Figure 6.3 Typical Extension Bonnet

## 6.5 Valves Subjected to Cavitation and Fluids with Particulate

Pressure and temperatures in today's process and oil recovery facilities continue to climb. As those pressures and resultant pressure drops increase, the propensity for cavitation to occur also increases.

With that can come additional particulate in the fluid. As the fluid becomes dirtier, the potential for clogging the small holes used for

cavitation abatement increases.

Special trims are available that can handle pressure drops in excess of 6000 psig while still allowing particulate to pass that is up to 1.27 cm (½-inch) in size. ■

## 6.6 Customized Characteristics, Noise Abatement, and Cavitation Mitigation Trims

Although control valve characteristics used in standard control valves (Figure 6.4) meet the requirements of most applications, often custom characteristics are needed for a given application. In these instances, special trim designs can be manufactured that meet these requirements. For contoured plugs, the design of the plug tip can be modified so that as the plug is moved through its travel range, the unobstructed flow area changes in size to allow for the generation of the specific flow characteristic. Likewise, cages can be redesigned to meet specific characteristics as well. This is especially common in noise abatement and anti-cavitation type trims where a high level of protection may be required at low flow rates but much lower protection levels are required for the higher flow rate conditions. ■

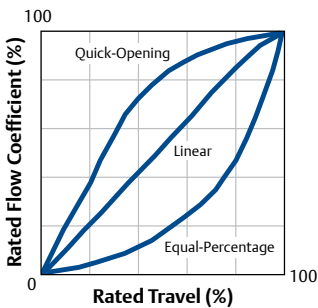

Figure 6.4 Inherent Valve Characteristic

## 6.7 Control Valves for Nuclear Service in the U.S.

Since 1970, U.S. manufacturers and suppliers of components for nuclear power plants have been subject to the requirements of *Appendix B, Title 10, Part 50* of the *Code of Federal Regulations* entitled *Quality Assurance Criteria for Nuclear Power Plants and Fuel Reprocessing Plants*. The U.S. Nuclear Regulatory Commission enforces this regulation. Ultimate responsibility of proof of compliance to Appendix B rests with the owner of the plant, who must in turn rely on the manufacturers of various plant components to provide documented evidence that the components were manufactured, inspected, and tested by proven techniques performed by qualified personnel according to documented procedures.

In keeping with the requirements of the *Code of Federal Regulations*, most nuclear power plant components are specified in accordance with *Section III* of the *ASME Boiler and Pressure Vessel Code* entitled *Nuclear Power Plant Components*. All aspects of the manufacturing process must be documented in a quality control manual and audited and certified by ASME before actual manufacture of the components. All subsequent manufacturing materials and operations are to be checked by an authorized inspector. All valves manufactured in accordance with Section III requirements receive an ASME code nameplate and an N stamp symbolizing acceptability for service in nuclear power plant applications.

Section III does not apply to parts not associated with the pressure-retaining function, to actuators and accessories unless they are pressure retaining parts, to deterioration of valve components due to radiation, corrosion, erosion,



seismic or environmental qualifications, or to cleaning, painting, or packaging requirements.

However, customer specifications normally cover these areas. Section III does apply to materials used for pressure retaining parts, to design criteria, to fabrication procedures, to non-destructive test procedures for pressure retaining parts, to hydrostatic testing, and to marking and stamping procedures. ASME Section III is revised by means of semi-annual addenda, which may be used after date of issue, and which become mandatory six months after date of issue. ■

## 6.8 Valves Subjected to Sulfide Stress Cracking

NACE International is a technical society concerned with corrosion and corrosion-related issues. NACE is responsible for a large number of standards, but by far the most influential and well known is MR0175, formerly entitled “Sulfide Stress Cracking-Resistant Metallic Materials for Oilfield Equipment.” MR0175 was issued by NACE in 1975 to provide guidelines for the selection of materials that are resistant to failure in hydrogen sulfide-containing oil and gas production environments. MR0175 has been so widely referenced that, throughout the process industry, the term “NACE” has become nearly synonymous with “MR0175.” However, the situation changed in 2003.

MR0175 was modified significantly in a 2003 revision to cover chloride stress corrosion cracking, in addition to sulfide stress cracking. Then, in late 2003, the document was revised and released as a joint NACE/ISO document called NACE MR0175/ISO 15156, “Petroleum and Natural Gas Industries—Materials for Use in H<sub>2</sub>S-Containing Environments in Oil

and Gas Production.”

In April 2003, NACE also released a new standard, MR0103, which is entitled, “Materials Resistant to Sulfide Stress Cracking in Corrosive Petroleum Refining Environments.” This standard is essentially the refining industry’s “NACE MR0175.” MR0103 only addresses sulfide stress cracking, and as such is similar in many respects to the pre-2003 revisions of MR0175. Use of the MR0103 standard in the refining industry is accelerating.

In 2013, the document was revised, reformatted, and released as an ISO document called ISO 17945, titled “Petroleum, Petrochemical, and Natural Gas Industries – Metallic Materials Resistant to Sulfide Stress Cracking in Corrosive Petroleum Refining Environments. In 2015, this was adopted by NACE as MRO103/ISO 17945.

Note that compliance with certain revisions of NACE MR0175 or NACE MR0175/ISO 15156 is mandated by statute in some states and regions in the U.S.A. At this time, NACE MR0103/ISO 17945 is not mandated by any governing bodies.

### 6.8.1 Pre-2003 Revisions of NACE MR0175

The following statements, although based on information and requirements in the pre-2003 revisions of MR0175, cannot be presented in the detail furnished in the actual standard and do not guarantee suitability for any given material in hydrogen sulfide-containing sour environments. The reader is urged to refer to the actual standard before selecting control valves for sour service.

- Most ferrous metals can become susceptible to sulfide stress cracking (SSC) due to hardening by heat treatment and/or cold work. Conversely, many ferrous metals

can be heat treated to improve resistance to SSC.

- Carbon and low-alloy steels must be properly heat treated to provide resistance to SSC. A maximum hardness limit of HRC 22 applies to carbon and low-alloy steels.
- Austenitic stainless steels are most resistant to SSC in the annealed condition; some specific grades and conditions of stainless steels are acceptable up to 35 HRC.
- Copper-based alloys are inherently resistant to SSC, but are generally not used in critical parts of a valve without the approval of the purchaser due to concerns about general corrosion.
- Nickel alloys generally provide the best resistance to SSC. Some precipitation-hardenable nickel alloys are acceptable for use in applications requiring high strength and/or hardness up to 40 HRC.
- Chromium, nickel, and other types of plating offer no protection against SSC. Their use is allowed in sour applications for wear resistance, but they cannot be used in an attempt to protect a non-resistant base material from SSC.
- Weld repairs and fabrication welds on carbon and low-alloy steels must be properly processed to ensure that they meet the 22 HRC maximum hardness requirement in the base metal, heat-affected zone (HAZ), and weld deposit. Alloy steels require post-weld heat treatment, and post-weld heat treatment is generally used for carbon steels as well.
- Conventional identification stamping is permissible in low stress areas, such as on the outside diameter of line flanges. Low-stress identification stamping must be used in other areas.
- The standard precludes using ASTM A193 Grade B7 bolting for applications that are considered “exposed.” Use of SSC-resistant

bolting materials (such as ASTM A193 Grade B7M) sometimes necessitates derating of valves designed originally to use B7 bolting. For example, in a Class 600 globe valve, 17-4PH H1150 DBL bolting was often used to avoid derating.

### 6.8.2 NACE MR0175/ISO 15156

NACE MR0175/ISO 15156 introduced significant changes to the standard. However, many end users continue to specify NACE MR0175-2002, feeling that it adequately meets their needs in providing good service life. The most significant changes in NACE MR0175/ISO 15156 include:

- The 17-4PH H1150 DBL bolting that was previously used for full-rated exposed bolting in a Class 600 globe valve is no longer allowed.
- The revision addresses both sulfide stress cracking and chloride stress corrosion cracking. Prior versions simply listed most materials as acceptable or unacceptable. Because its scope was expanded to cover chloride stress corrosion cracking, the new standard lists all corrosion-resistant alloys as acceptable within limits, referred to as “environmental limits or environmental restrictions.” These are typically expressed in terms of H<sub>2</sub>S partial pressure, maximum temperature, ppm chlorides, and the presence of free sulfur.
- 316 usage is still allowed but under very limited environmental conditions. The impact, if strictly followed, is that this material will find very little use.
- The standard applies only to petroleum production, drilling, gathering and flow line equipment, and field processing facilities to be used in H<sub>2</sub>S bearing hydrocarbon service. It does not apply to refineries.
- There is clear responsibility placed on the buyer or user to specify the



correct materials. The manufacturer is only responsible for meeting the metallurgical requirements of MR0175/ISO 15156, but not to specify the correct materials.

### 6.8.3 NACE MR0103

As mentioned, NACE MR0103 is similar in many respects to the pre-2003 revisions of NACE MR0175. The following are some major differences:

- MR0103 utilizes different, refinery-based definitions for what constitutes a sour environment. The user is responsible for imposing the requirements of MR0103 when they are applicable.
- The 2002 and older revisions of MR0175 included environmental restrictions on a few materials that were continued in the latter editions. MR0103 only deals with sulfide stress cracking. It does not impose environmental limits on any materials. Materials are either acceptable or not.
- Carbon steel base materials that are classified as P-No. 1, group 1 or 2 steels in the ASME Boiler and Pressure Vessel Code are acceptable per MR0103 without base metal hardness requirements. P-No. 1 groups 1 and 2 include WCC and LCC castings, A105 forgings, A516 Grade 70 plate, and the other common carbon steel pressure vessel materials.
- MR0103 imposes welding controls on carbon steels that are more rigorous than those imposed by MR0175-2002. MR0103 requires that P-No. 1 carbon steels be welded per another NACE document called RP0472 “Methods and Controls to Prevent In-Service Environmental Cracking of Carbon Steel Weldments in Corrosive Petroleum Refining Environments.” RP0472 imposes controls that ensure both the weld deposit and heat affected zone (HAZ) in a weldment will be soft enough to resist sulfide stress cracking. RP0472 invokes actual hardness testing of weld deposits in production, although hardness testing is waived if certain welding process/filler material combinations are employed. HAZ hardness may be controlled by either post-weld heat treatment (PWHT) or by base material chemistry restrictions such as imposing a maximum carbon equivalent (CE).
- Like the 2003 and later revisions of MR0175, MR0103 does not allow the use of S17400 double H1150 material for bolting. This means that the 17-4PH H1150 DBL bolting that was previously used for full-rated exposed bolting in a Class 600 valve is no longer allowed. ■

# Chapter 7

## Steam Conditioning



## 7.1 Understanding Desuperheating

Superheated steam provides an excellent source of energy for mechanical power generation. However, in many instances, steam at greatly reduced temperatures, near saturation, proves a more desirable commodity. This is the case for most heat-transfer applications. Precise temperature control is needed to improve heating efficiency, eliminate unintentional superheat in throttling processes, or to protect downstream product and/or equipment from heat related damage. One method to reduce temperature is the installation of a desuperheater.

A desuperheater injects a controlled, predetermined amount of water into a steam flow to lower the temperature of the steam. To achieve this efficiently, the desuperheater must be designed and selected correctly for the application. Although it can appear simplistic in design, the desuperheater must integrate with a wide variety of complex thermal and flow dynamic variables to be effective.

The control of the water quantity, and thus the steam temperature, uses a temperature control loop. This loop includes a downstream temperature sensing device, a controller to interpret the measured temperature relative to the desired set point, and the transmission of a proportional signal to a water controlling valve/actuator assembly to meter the required quantity of water.

The success or failure of a particular desuperheater installation rests on a number of physical, thermal, and geometric factors. Some of these are obvious and some obscure, but all of them have a varying impact on the performance of the equipment and the system in which it is installed.

The first—and probably most important—

factor for efficient desuperheater operation is to select the correct design for the respective application. Desuperheaters come in all shapes and sizes and use various energy transfer and mechanical techniques to achieve the desired performance within the limits of the system environment. Another section details the differences in the types of desuperheaters available and expected performance.

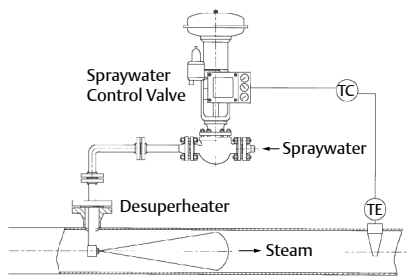

Figure 7.1 Typical Insertion-Style Desuperheater Installation and Temperature Control Loop

### 7.1.1 Technical Aspects of Desuperheating

Some of the physical parameters that affect the performance of a desuperheating system include:

- Installation orientation
- Downstream straight pipe length
- Spraywater temperature and pressure
- Spraywater quantity
- Pipeline or liner size
- Steam density
- Method of atomization
- Steam velocity
- Equipment versus system turndown

Installation orientation is an often overlooked—but critical—factor in the performance of the system. Correct placement of the desuperheater can have a greater impact on system

operation than the style of the unit itself. For most units, the optimum orientation is in a vertical pipeline with the flow direction up. This is contrary to most installations seen in industry today. Other orientation factors include pipe fittings, elbows, and any other type of pipeline obstruction that exists downstream of the water injection point.

Figure 7.2 illustrates variations in the installation of a desuperheater. It is important to note that almost any orientation can be made to work if all parameters are correctly incorporated into the design of the system.

Spraywater temperature can have a significant impact on desuperheater performance. Although it goes against logical convention, high-temperature water is better for cooling. As the spraywater temperature increases, flow and thermal characteristics improve and impact the following:

- Surface tension
- Droplet size distribution
- Latent heat of vaporization
- Vaporization rate

Improvements in all these areas, as a result of increased spraywater temperature, improves the overall performance of the system.

Equally as important is the pressure drop available across the spraywater system (spraywater valve and nozzle). Increasing the pressure drop available across this system can result in significantly shorter straight pipe length requirements downstream of the desuperheating device.

The quantity of water to be injected will have a directly proportional effect on the time for vaporization. The heat transfer process is time-dependent and thus the quantity of spraywater will affect the time for complete vaporization and thermal stability.

To determine the spraywater required ( $Q_w$ ) as a function of inlet steam flow ( $Q_1$ ), perform a simple heat balance using the following equation:

$$Q_w(\text{mass}) = Q_1 * \left( \frac{H_1 - H_2}{H_2 - H_w} \right)$$

Where  $Q$  is the mass flow in PPH and  $H$  is the individual enthalpy values at the inlet, outlet, and spraywater.



Figure 7.2 Desuperheating Installations

When the calculation is performed as a function of outlet steam flow ( $Q_2$ ), that is, the combination of inlet steam flow and desuperheating spraywater, use the following equation:

$$Qw(\text{mass}) = Q_2 * \left( \frac{H_1 - H_2}{H_w - H_1} \right)$$

To perform a basic  $C_v$  calculation for initial desuperheater sizing, it is required that the resultant  $Qw(\text{mass})$  is converted to  $Qw(\text{volumetric})$ . When using English units, the conversion is done as follows:

$$Qw(\text{volumetric}) = \frac{Qw(\text{mass}) * 0.1247}{pw}$$

$Qw(\text{volumetric})$  is in GPM and  $pw$  is the density of the spraywater in  $\text{lbm}/\text{Ft}^3$ .

Based on this conversion, the sizing can be completed with the following  $C_v$  calculation for each set of conditions:

$$C_v = Qw(\text{volumetric}) * \sqrt{\frac{SG}{\Delta Pdsh}}$$

Where  $SG$  is the specific gravity of the spraywater and  $\Delta Pdsh$  is the pressure differential across the proposed desuperheater.

When designing a new desuperheater installation, another concern for proper system performance is the pipeline size. As the line size gets larger, more attention must be paid to the penetration velocity of the spray and the coverage in

the flow steam (Figure 7.3).

Some single-point, injection-type desuperheaters have insufficient nozzle energy to disperse throughout the entire cross sectional flow area of the pipeline. As a result, the spray pattern collapses and thermal stratification occurs. A subcooled center core is formed that is shrouded with superheated steam. This condition is normally eliminated after the flow stream has undergone several piping directional changes, but this is not always possible within the limits of the control system or process. Proper placement of high-energy, multi-nozzle units in the larger pipelines normally prevents the formation of thermal stratification.

The maximum and minimum velocity of the steam has a direct relationship on the successful mixing of the water. The velocity directly affects the residence time available for the water to mix with the steam. When the maximum velocity is too high, there potentially is not enough time for the water to mix before it encounters a piping obstruction such as an elbow or tee. Ideal maximum velocity for pipelines usually ranges from 150-250 feet per second (46-76 meters per second). Note that higher localized velocities at point of injection can be beneficial. When the minimum velocity is too low, turbulence is reduced and the water droplets tend to fall out of suspension in the steam. As a rule, the minimum steam velocity in which water



Figure 7.3 Desuperheater Spray Penetration

can remain suspended is approximately 15-30 feet per second (4.5-9 meters per second) for spring loaded nozzles. For applications with lower velocities, proper mixing may be achieved with desuperheaters that offer a venturi or atomizing steam.

One of the most over-used and misunderstood concepts in the area of desuperheating is turndown. When applied to a final control element, such as a valve, turndown is a simple ratio of the maximum to the minimum controllable flow rate. Turndown is sometimes used interchangeably with rangeability. However, the exact meaning differs considerably when it comes to actual performance comparisons.

A desuperheater is not a final control element, and as such, its performance is directly linked to its system environment. Each component of the desuperheater system has a rangeability all its own (steam PRV, water TCV, pipe steam velocity, nozzle dP). The actual system turndown is more a function of the system parameters rather than based on the equipment's empirical flow variations. Once this is understood, it is obvious that a good desuperheater cannot overcome the failings of a poor system. They must be evaluated on their own merits and weighted accordingly.

Even with improved nozzle design technology, pipe liners are often specified, especially in areas of the HRSG where interstage or final stage attemperators are required. Liners are rarely used in turbine bypass applications.

Due to the particulate often present in spray water systems and piping, inline strainers are always required. Mesh size is dependent on the particular nozzle size selected for the application and will be specified as part of the design. Failure to ignore these mesh sizes may result in improper desuperheating or pipe damage.

The previous calculations and recommendations provide the necessary information to select the proper desuperheater design and size. This selection should be based on a variety of application considerations such as:

- Minimum to maximum load requirement rangeability
- Minimum and maximum steam velocity
- Straight pipe length and temperature sensor distance downstream of the desuperheater
- Steam pipe line size and schedule
- Pressure differential between water and steam ■

## 7.2 Typical Desuperheater Designs

### 7.2.1 Fixed-Geometry Nozzle Design

The fixed-geometry nozzle design (Figure 7.4) is a simple mechanically atomized desuperheater with single or multiple fixed-geometry spray nozzles. It is intended for applications with nearly constant load changes (rangeability up to 5:1) and is capable of proper atomization in steam flow velocities as low as 25-30 feet per second under optimum conditions.



Figure 7.4 Fixed-Geometry Nozzle Design

Standard installation of this type of unit is through a flanged branch connection tee on a NPS 6 (DN 150) or larger steam pipe line. This design is usually not available for large  $C_v$  requirements. This unit requires an external water control valve to meter water flow based on a signal from a temperature sensor in the downstream steam line.

### 7.2.2 Variable-Geometry Nozzle Design

The variable-geometry nozzle design (Figure 7.5) is also a simple mechanically atomized desuperheater, but it employs one or more variable-geometry, back pressure activated spray nozzles. Due to the variable-geometry, this unit can handle applications requiring control over moderate load changes (rangeability up to 20:1) and is capable of proper atomization in steam flow velocities as low as 25-30 feet per second under optimum conditions. Standard installation of this type of unit is through a flanged branch connection tee on a NPS 8 (DN 200) or larger steam pipe line. These units are available for moderate  $C_v$  requirements. This design requires an external water control valve to meter water flow based on a signal from a temperature sensor in the downstream steam line.



Figure 7.5 Variable-Geometry Nozzle Design

### 7.2.3 Self-Contained Design

The self-contained design (Figure 7.6) is also mechanically atomized with one or more variable-geometry, backpressure-activated spray nozzles. As a special feature, this unit incorporates a water flow control element packaged to a desuperheating device. This combination works just like a separate spray water valve and desuperheater but is packaged together to minimize space constraints and piping modification necessary on existing installations. Because of the close coordination of the intrinsic control element and the variable-geometry nozzle(s), this unit can handle applications requiring control over moderate to high load changes (rangeability up to 25:1). It offers proper atomization in steam flow velocities as low as 25-30 feet per second under optimum conditions. Standard installation of this type of unit is through a flanged branch connection tee on a NPS 8 (DN 200) or larger steam pipe line. These are available for moderate  $C_v$  requirements.



Figure 7.6 Self-Contained Design

### 7.2.4 Steam-Atomized Design

The steam-atomized design (Figure 7.7) incorporates the use of high-pressure steam for rapid and complete

atomization of the spraywater. This is especially useful in steam pipe lines that have low steam velocity. The atomizing steam, usually twice the main steam line pressure or higher, encounters the water in the spray nozzle chamber where the energy of the expanding atomizing steam is used to atomize the water into very small droplets. These smaller droplets allow for faster conversion to steam and permit the water to remain suspended in a low steam velocity flow, thereby allowing complete vaporization to occur. The steam-atomized design, therefore, can properly mix water into steam flow velocities as low as approximately 10 feet per second under optimum conditions. This design handles applications requiring very high load changes (rangeability up to 50:1).

Standard installation of this type of unit is through a flanged branch connection tee on a NPS 8 (DN 200) or larger steam pipe line. This design is available for moderate  $C_v$  requirements. It requires an external water control valve to meter water flow based on a signal from a temperature sensor in the downstream steam line. This system also requires a separate on/off valve for the atomizing steam supply.

### 7.2.5 Geometry-Assisted Wafer Design

The geometry-assisted wafer design (Figure 7.9) was originally developed for small steam pipe line sizes of less than NPS 6 (DN 150) that were unable to accommodate an insertion-style



Figure 7.7 Steam-Atomized Design



Figure 7.9 Geometry-Assisted Wafer Design

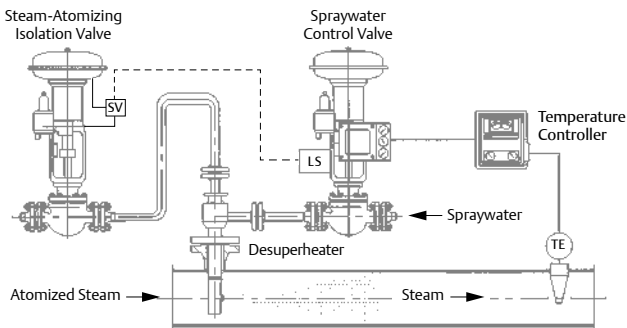

Figure 7.8 Control Loop with Steam-Assisted Desuperheater



desuperheater. The unit is designed as a wafer that is installed between two flanges in the steam pipe line. A reduced diameter throat venturi allows water to spray completely around the wafer and permits multiple points of spraying either through drilled holes or small nozzles. In addition, the venturi increases the steam velocity at the point of injection, which enhances atomization and mixing in steam flow velocities as low as approximately 15 feet per second under optimum conditions. It handles applications requiring control over moderate load change (rangeability up to 20:1). It can be installed in steam pipe line sizes of NPS 1 through NPS 24 (DN 25 through DN 600), and is available for moderate  $C_v$  requirements. This design requires an external water control valve to meter water flow based on a signal from a temperature sensor in the downstream steam line. ■

### 7.3 Understanding Steam Conditioning Valves

A steam conditioning valve is used for the simultaneous reduction of steam pressure and temperature to the level required for a given application. Frequently, these applications deal with high inlet pressures and temperatures and require significant reductions of both properties. They are, therefore, best manufactured in a forged and fabricated body that can better withstand steam loads at elevated pressures and temperatures. Forged materials permit higher design stresses, improved grain structure, and an inherent material integrity over cast valve bodies. The forged construction also allows the manufacturer to provide up to Class 4500, as well as intermediate class ratings. Castings may still be an option when globe-style bodies are required or lower pressures and

temperatures are present.

Due to frequent extreme changes in steam properties as a result of the temperature and pressure reduction, the forged and fabricated valve body design allows for the addition of an expanded outlet to control outlet steam velocity at the lower pressure. Similarly, with reduced outlet pressure, the forged and fabricated design allows the manufacturer to provide different pressure class ratings for the inlet and outlet connections to more closely match the adjacent piping.

Other advantages of combining the pressure reduction and desuperheater function in the same valve versus two separate devices include:

- Improved spraywater mixing due to the optimum utilization of the turbulent expansion zone downstream of the pressure reduction elements
- Improved rangeability
- Ease of installing and servicing only one device

Several available steam conditioning valve designs meet various applications. Typical examples of these follow. ■

### 7.4 Steam Conditioning Valves

Steam conditioning valves represent state-of-the-art control of steam pressure and temperature by combining both functions within one integral control unit. These valves address the need for better control of steam conditions brought on by increased energy costs and more rigorous plant operation. Steam conditioning valves also provide better temperature control, improved noise abatement, and require fewer piping and installation restrictions than the equivalent desuperheater and

pressure reduction station.

The steam conditioning valve shown in Figure 7.10 combines pressure and temperature control in a single valve. Finite element analysis (FEA) and computational fluid dynamic (CFD) tools were used in its development to qualify its structural integrity as well as optimize the valve's operating performance and overall reliability. The rugged design of this steam conditioning valve proves capable of handling full-pressure main steam drops, while its flow-up configuration in conjunction with control valve noise abatement technology prevents the generation of excessive noise and vibration.

The simplified trim configuration (Figure 7.10) used in the steam conditioning valve accommodates rapid changes in temperature, as experienced during a turbine trip. The cage is case hardened for maximum life and is allowed to expand during thermally induced excursions. The valve plug is continuously guided and utilizes cobalt-based overlays both as guide bands and to provide tight, metal-to-metal shutoff against the seat.



Figure 7.10 Cross-Section View of Steam Conditioning Valve

The steam conditioning valve incorporates a spraywater manifold downstream of its pressure reduction stage. The manifold features variable-geometry, backpressure activated spray nozzles that maximize mixing and quick

vaporization of the spraywater.

The spray nozzle (Figure 7.11) was developed originally for condenser dump systems in which the downstream steam pressure can fall below the saturation level. These style nozzles allow for improved equipment turndown by reducing the minimum flow. This is accomplished through nozzle backpressure at lower dP. Also beneficial is that an increased nozzle dP at lower openings allows the water to flash across the nozzle exit instead of across the spray water valve trim.

Spring loading of the nozzle plug within the spray nozzle prevents any such changes by forcing the plug to close when flashing occurs. With flashing, the compressibility of the fluid changes, and the nozzle spring will force closure and re-pressurization of the fluid leg. Once this is done, the fluid will regain its liquid properties and reestablish flow to the condenser.



Figure 7.11 Variable-Geometry, Backpressure-Activated Spray Nozzle

The steam conditioning valve injects the spray water towards the center of the pipeline and away from the pipe wall. The number of injection points varies by application. With high differentials in steam pressure, the outlet size of the valve increases drastically to accommodate the larger specific volumes. Correspondingly, an increased number of nozzles are arranged around the circumference of the outlet, making for a more even and complete distribution of the spray water.

The simplified trim arrangement in the steam conditioning valve permits

extending its use to higher pressure classes (through ANSI Class 2500 or higher) and operating temperatures. Its balanced plug configuration provides Class V shutoff and a linear flow characteristic.

The steam conditioning valve typically uses high-performance, pneumatic piston actuators in combination with a digital valve controller to achieve a full stroke in less than two seconds while maintaining highly accurate step response.

When piping dictates, the steam conditioning valve can be provided as separate components, allowing pressure control in the valve body and temperature reduction in a downstream steam cooler. Also cast globe bodies can be provided and used in combination with insertion-style desuperheaters for more economical purposes.

#### 7.4.1 Steam Attemperator

The steam attemperator (Figure 7.12) is normally used when an application requires a separation of the pressure reduction and desuperheating functions. The steam cooler is equipped with a water supply manifold. The manifold (multiple manifolds are possible) provides cooling water flow to a number of individual spray nozzles installed in the pipe wall of the outlet section. The result is a fine spray injected radially into the high turbulence of the axial steam flow. The combination of large contact surface area of the water and high turbulence in the steam make for very efficient mixing and rapid vaporization.



Figure 7.12 Ring-Style Attemperator with Liner

#### 7.4.2 Steam Sparger

Steam spargers (Figure 7.13) are pressure-reducing devices used to safely discharge steam into a condenser or turbine exhaust duct. In addition, the steam sparger provides backpressure to the turbine bypass valve, limits steam velocity and allows reduced pipe size between the bypass valve and sparger. Sparger design and installation are both key elements when considering total system noise. The design of the sparger is critical to a properly functioning turbine bypass system. To address flow-induced noise, steam spargers can employ various noise abatement technologies. ■



Figure 7.13 Steam Sparger with Drilled-Hole Noise Control Technology

### 7.5 Understanding Turbine Bypass Systems

The turbine bypass system has evolved over the last few decades as the mode of power plant operations has changed. It is employed routinely in utility power plants where operations require quick response to wide swings in energy demands. A typical day of power plant operation might start at minimum load, increase to full capacity for most of the day, rapidly reduce back to minimum output, then up again to full load—all within a 24-hour period. Boilers, turbines, condensers and other associated equipment cannot respond properly to such rapid changes without some form of turbine bypass system.

The turbine bypass system allows operation of the boiler independent of the turbine. In the start-up mode, or rapid reduction of generation requirement, the turbine bypass not only supplies an alternate flow path for steam, but conditions the steam to the same pressure and temperature normally produced by the turbine expansion process. By providing an alternate flow path for the steam, the turbine bypass system protects the turbine, boiler, and condenser from damage that may occur from thermal and pressure excursions. For this reason, many turbine bypass systems require extremely rapid open/close response times for maximum equipment protection. This is accomplished with an actuation system that provides both the forces and controls for such operation.

Additionally, when commissioning a new plant, the turbine bypass system allows start up and check out of the boiler separately from the turbine.

This allows for quicker plant start-ups, which results in attractive economic gains. It also means that this closed-loop system can prevent atmospheric loss of treated feedwater and reduction of ambient noise emissions. ■

## 7.6 Turbine Bypass System Components

The major elements of a turbine bypass system are turbine bypass valves, turbine bypass water control valves, and the actuation system.

### 7.6.1 Turbine Bypass Valves

Whether for low-pressure, intermediate pressure, or high-pressure applications, turbine bypass valves usually require tight shutoff (Class V). Because of particular installation requirements these manifold design valves will occasionally

be separated into two parts: the pressure-reducing portion of the valve and then the outlet/manifold cooler section located closer to the condenser.

Selecting a turbine bypass control valve for this complex process should first be done by understanding the performance goals that need to be accomplished, what real piping geometry exists or is planned, and determining what process controls are needed. Once this is understood, other factors such as control valve style and size, pressure and flow control needs, noise specification requirements, material requirements, and operational practices of the process can be incorporated. Many variations are possible and range from separate globe bodies with downstream desuperheaters to devices that incorporate pressure and temperature control in one unit.

Turbine bypass valve designs can vary considerably, as do the applications they are required to handle. Each has particular characteristics or options that yield efficient operation over a wide range of conditions and customer specified requirements. Turbine bypass valves are often customized to specific installations. Rarely are any two turbine bypass valves installations identical.

Separate globe or angle valve bodies with downstream desuperheating devices can be selected that conveniently fit into the piping layouts already in place. Sliding-stem control valves are designed to provide precise flow control. They also can incorporate noise abatement trims that are often needed for the large pressure drops seen in steam letdown and turbine bypass applications. This approach can accommodate mild to severe application ranges.

### 7.6.2 Turbine Bypass Water Control Valves

These valves are required to control the

flow of the water to the turbine bypass valves. Due to equipment protection requirements, it is imperative that these valves provide tight shutoff (Class V). Valve trim requirements can range from standard trim to cavitation-reduction styles.

### 7.6.3 Actuation

In typical bypass systems, it has been common practice to trip the bypass valves to a preset opening corresponding to a predetermined flow rate demand during a plant event. However, the valves have to be left in manual for a specific amount of time until the systems stabilized before they could switch over to automatic operation. This requires specialized algorithms and control logic that increases operation complexity which, up until a few year ago, was unavoidable.

However, in today's power market, the limits of turbine bypass systems are being pushed. Instead of having to worry about putting the bypass valves in manual during a plant event, installations are using high performance actuation to respond with both fast and precise control to meet various plant demands.

Turbine bypass valves must be responsive in order to protect critical and costly turbines from damage during transients. They also must be accurate to allow operation at peak efficiency.

An understanding of the stroking speed and control requirements may necessitate complex actuation packages designed to meet the requirements of the process. Typically,  $s$  of 2-4 seconds are required to move the valve position to anywhere 85-100% travel from any position. Precision actuation technology is required to not only trip this valve quickly but do so with better than 1% positioning accuracy for even very large control valves.

Setup and tuning should be accomplished within minutes with the capability of doing so remotely being highly desirable. On the software side, this is done through software packages that provide for tuning parameters set specifically for these types of valves. Parameters should be set to improve the response to small amplitude steps by overdriving the set point, asymmetrically adjust the response to set independently in the opening and closing times, and integrate real time graphics to allow for adjustments to be done remotely.

On the hardware side, pneumatic or hydraulic solutions are available to accomplish this difficult task. Both are well accepted solutions in the market and can be made to accomplish the same goal with minimal maintenance required. ■



Figure 7.14 Typical Actuation Package for Use in Turbine Bypass Applications

# Chapter 8

## Installation and Maintenance





Control valve efficiency directly affects process plant profitability. The role a control valve plays in optimizing processes is often overlooked. Many process plant managers focus most resources on distributed control systems and their potential for improving production efficiency. However, it is the final control element (typically a control valve) that actually creates the change in the process variable. If the valve is not working properly, no amount of sophisticated electronics at the front end will correct problems at the valve. As many studies have shown, control valves are often neglected to the point that they become the weak link in the process control scheme.

Control valves must operate properly, no matter how sophisticated the automation system or how accurate the instrumentation. With proper valve operation, you can achieve high yields, quality products, maximum profits, and energy conservation.

Optimizing control valve efficiency depends on:

1. Correct control valve selection for the application
2. Proper storage and protection
3. Proper installation techniques
4. An effective predictive maintenance program

Control valve selection is covered in Chapter 5. Proper storage and protection, installation techniques, and predictive maintenance are included in this chapter. ■

## 8.1 Proper Storage and Protection

Proper storage and protection should be considered early in the selection process, before the valve is shipped.

Typically, manufacturers have packaging standards that are dependent upon the destination and intended length of storage before installation. Because most valves arrive on site some time before installation, many problems can be averted by making sure the details of the installation schedule are known and discussed with the manufacturer at the time of valve selection. In addition, special precautions should be taken upon receipt of the valve at the final destination. For example, the valve must be stored in a clean, dry place away from any traffic or other activity that could damage the valve. ■

## 8.2 Proper Installation Techniques

Always follow the control valve manufacturer's installation instructions and cautions. Typical instructions are summarized next.

### 8.2.1 Read the Instruction Manual

Before installing the valve, read the instruction manual. Instruction manuals describe the product and review safety issues and precautions to be taken before and during installation. Following the guidelines in the manual helps ensure an easy and successful installation.

### 8.2.2 Be Sure the Pipeline Is Clean

Foreign material in the pipeline could damage the seating surface of the valve or even obstruct the movement of the valve plug, ball, or disk so that the valve does not shut off properly. To help reduce the possibility of a dangerous situation from occurring, clean all pipelines before installing. Make sure pipe scale, metal chips, welding slag, and other foreign materials are removed. In addition, inspect pipe flanges to ensure a smooth gasket surface. If the valve has screwed end connections,

apply a good grade of pipe sealant compound to the male pipeline threads. Do not use sealant on the female threads because excess compound on the female threads could be forced into the valve body.

Excess compound could cause sticking in the valve plug or accumulation of dirt, which could prevent good valve shutoff.



Figure 8.1 Arrow Depicting the Flow Direction on a Metal-Seated Ball Valve

### 8.2.3 Inspect the Control Valve

Although valve manufacturers take steps to prevent shipment damage, such damage is possible and should be discovered and reported before the valve is installed.

Do not install a control valve known to have been damaged in shipment or while in storage.

Before installing, check for and remove all shipping stops and protective plugs or gasket surface covers. Check inside the valve body to make sure no foreign objects are present.

### 8.2.4 Use Good Piping Practices

Most control valves can be installed in any position. However, the most common method is with the actuator vertical and above the valve body. If horizontal actuator mounting is necessary, consider additional vertical support for the actuator. Be sure the body is installed so that fluid flow will be in the direction indicated by the flow arrow (Figure 8.1) or instruction manual.

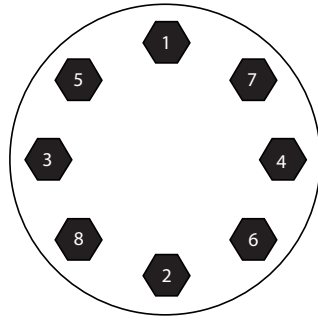

Figure 8.2 Tighten Bolts in a Criss-Cross Pattern

Be sure to allow ample space above and below the valve to permit easy removal of the actuator or valve plug for inspection and maintenance. Clearance distances are normally available from the valve manufacturer as certified dimension drawings. For flanged valve bodies, be sure the flanges are properly aligned to provide uniform contact of the gasket surfaces. Snug up the bolts gently after establishing proper flange alignment. Finish tightening them in a criss-cross pattern (Figure 8.2). Proper tightening will avoid uneven gasket loading and will help prevent leaks. It will also help avoid the possibility of damaging, or even breaking, the flange. This precaution is particularly important when connecting to flanges that are not the same material as the valve flanges.

Pressure taps installed upstream and downstream of the control valve are useful for checking flow capacity or pressure drop. Locate such taps in straight runs of pipe away from elbows, reducers, or expanders. This location minimizes inaccuracies resulting from fluid turbulence.

Use 1/4-inch or 3/8-inch (6-10 millimeters) tubing or pipe from the pressure connection on the actuator to the instrumentation. Keep this distance relatively short and minimize the number of fittings and elbows to reduce



system time lag. If the distance must be long, use a valve positioner or a volume booster to reduce any lag time.

### 8.2.5 Flushing/Hydro/Start-Up Trim

When welding socket weld-end or butt weld-end valves in-line, the control valve trim needs to be removed in order to prevent damage to trim parts. The trim also needs to be replaced with a temporary sacrificial trim set while conducting the system hydrostatic test and flushing the system.

**Note:** *It is strongly recommended that the final application trim not be installed until after the valve has been welded in the line, the line flushed, and hydrostatically tested*

After a valve or valves are welded in a line, there normally are requirements to hydro and flush the system. It is not uncommon for the system hydro to be consistent with codes that state that the hydro is to be conducted at 1-1/2 times the system cold working pressure or design pressure. Normally, the only valve components that may be adversely affected by this level of a hydro pressure (assuming that the valve is in the open position during hydro) would be the valve stem packing. PTFE packing may exhibit some extrusion resulting from a high-pressure hydro, and therefore it is recommended that at a minimum the PTFE packing should be replaced after a hydro test.

Graphite packing should not need to be replaced if the valve is to be put into service within a short time period. Leaving wet graphite packing in an inactive valve long term may result in galvanic corrosion of the valve stem.

However, since the system is normally flushed at the same time, a sacrificial set of trim should be installed to handle both hydro testing and flushing.

With some control valves and steam conditioning valves, the flushing

operation does not go through the valve from valve inlet to outlet. Because of the valve design or application, the flushing operation may either go in the valve inlet, or outlet (depending on configuration) and out the bonnet opening. This type of flushing trim is more commonly known as “blow down” or “blow out” trim.

Flushing the system presents some conditions that can damage the control valve trim. These conditions can include weld slag, rust, corrosion, etc. being flowed through the valve. These materials can damage the valve seating surface and will often plug drilled hole or stacked disk trims. Therefore, it is always recommended that the valve trim be removed and some form of expendable flushing trim installed. After welding valves in a line, there is usually weld slag inside the line, in addition to scale that has been dislodged from the inside of the valve piping due to temperatures associated with the welding process. If this material was flowed through the valve, it would likely plug the valve trim and possibly damage the seating integrity of the valve. ■

## 8.3 Control Valve Maintenance

Always follow the control valve manufacturer’s maintenance instructions. Typical maintenance topics are summarized here.

Optimization of control valve assets depends on an effective maintenance philosophy and program. Three of the most basic approaches are:

**Reactive** – Action is taken after an event has occurred. Wait for something to happen to a valve and then repair or replace it.

**Preventive** – Action is taken on a timetable based on history; that is, try to

prevent something bad from happening.

**Predictive** – Action is taken based on field input using state-of-the-art, non-intrusive diagnostic test and evaluation devices or using smart instrumentation.

Although both reactive and preventive programs work, they do not optimize valve potential. Following are some of the disadvantages of each approach.

### 8.3.1 Reactive Maintenance

Reactive maintenance allows subtle deficiencies to go unnoticed and untreated, simply because there is no clear indication of a problem. Even critical valves might be neglected until they leak excessively or fail to stroke properly. In some cases, feedback from production helps maintenance react before serious problems develop, but valves might be removed unnecessarily on the suspicion of malfunction. Large valves or those welded in-line can require a day or longer for removal, disassembly, inspection, and re-installation. Time and resources could be wasted without solving the problem if the symptoms are actually caused by some other part of the system.

### 8.3.2 Preventive Maintenance

Preventive maintenance generally represents a significant improvement. However, because maintenance schedules have been able to obtain little information on valves that are operating, many plants simply overhaul all control valves on a rotating schedule. Such programs result in servicing some valves that need no repair or adjustment and leaving others in the system long after they have stopped operating efficiently.

### 8.3.3 Predictive Maintenance

Today, plant operators often extend the time between turnarounds to three or four years, and even longer, in order to maximize plant uptime. These extended run times offer less opportunity for traditional, out-of-service valve diagnostics.

The traditional maintenance process consists of four distinct modes:

**Fault Detection** – A majority of valve maintenance effort is spent in monitoring valves while in service to detect the occurrence of a fault. When a fault is identified, the maintenance process transitions to fault discrimination.

**Fault Discrimination** – During this mode, valve assets are evaluated to determine the cause of the fault and to establish a course of corrective action.

**Process Recovery** – Corrective action is taken to fix the source of the defect.

**Validation** – In this final mode, valve assets are evaluated relative to either as-new condition or the last established baseline condition. Once validated, the maintenance process returns to fault detection status.

### 8.3.4 Using Control Valve Diagnostics

The advent of micro-processor-based valve instruments with their in-service diagnostics capabilities has allowed companies to redesign their control valve maintenance work practices.

These digital devices significantly improve the fault detection and discrimination aspects of traditional maintenance programs.

For example, in-service diagnostics (Figure 8.3) can detect problems with instrument air quality, leakage and supply pressure restriction, and can

identify valve problems, such as excessive friction, deadband, and falling out of calibration. When a problem is identified, its severity is reported, possible causes are listed, and a course of action is given. These diagnostics typically result in one of three conditions:

- No fault detected (green condition). The valve should remain in service, and monitoring should continue.
- A warning that a fault has been detected, but control remains unaffected (yellow condition). This is a predictive indication that the detected problem has the potential to affect control and that future maintenance should be planned.
- An error report that a fault affecting control has been detected (red condition). These faults generally require immediate attention.

More specifically, in-service diagnostics oversee instrument air leakage, supply pressure, travel deviation and relay adjustment, instrument air quality, friction, etc.

### 8.3.4.1 Instrument Air Leakage

Air mass flow diagnostics measure instrument air flow through the actuator

assembly. Because of multiple sensors, this diagnostic can detect both positive (supply) and negative (exhaust) air mass flow from the digital valve controller. This diagnostic not only detects leaks in the actuator or related tubing, but also much more difficult problems. For example, in piston actuators, the air mass flow diagnostic can detect leaking piston seals or damaged o-rings.

### 8.3.4.2 Supply Pressure

The supply pressure diagnostic detects control valve problems related to supply pressure. This in-service diagnostic will detect both low and high supply pressure readings. In addition to checking for adequate supply pressure, this diagnostic can be used to detect and quantify droop in the air supply during large travel excursions. This is particularly helpful in identifying supply line restrictions.

### 8.3.4.3 Travel Deviation and Relay Adjustment

The travel deviation diagnostic is used to monitor actuator pressure and travel deviation from setpoint. This diagnostic is useful in identifying a stuck control

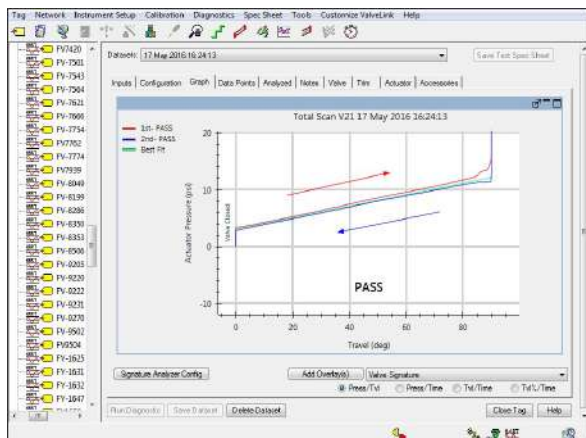

Figure 8.3 Non-Intrusive Diagnostics Program for Predictive Maintenance

valve, active interlocks, low supply pressure, or shifts in travel calibration.

The relay adjustment diagnostic is used to monitor crossover pressure on double-acting actuators. If the crossover pressure is too low, the actuator loses stiffness, making the valve plug position susceptible to being overcome by process forces. If the crossover pressure is set too high, both chambers will be near supply, the pneumatic forces will be roughly equal, the spring force will be dominant and the actuator will move to its spring-fail position.

#### 8.3.4.4 Instrument Air Quality

The I/P and relay monitoring diagnostic can identify problems such as plugging in the I/P primary or in the I/P nozzle, instrument diaphragm failures, I/P instrument o-ring failures, and I/P calibration shifts. This diagnostic is particularly useful in identifying problems from contaminants in the air supply and from temperature extremes.

#### 8.3.4.5 In-Service Friction and Friction Trending

The in-service friction and deadband diagnostic determines friction in the valve assembly as it is controlled by the control system. Friction diagnostics data is collected and trended to detect valve changes that affect process control.

#### 8.3.4.6 Other Examples

In-service custom diagnostics can be configured to collect and graph any measured variable of a smart valve. Custom diagnostics can locate and discriminate faults not detectable by other means. Often, these faults are complicated and require outside expertise. In such cases, data is collected by local maintenance personnel and is then sent to a valve condition monitoring specialist for further analysis. Therefore, avoiding the costs and delays

associated with an on-site visit.

### 8.3.5 Continued Diagnostics Development

Overall, the process industries will continue to demand more and more efficiency in terms of quality, yield, and reliability. Individually, producers will continue to lengthen time between turnarounds. These demands will lead to fewer maintenance opportunities being available for instrumentation repair. The inevitable answer to this shortfall will be future diagnostic developments that focus on in-service, non-intrusive test and evaluation capabilities, such as valve condition monitoring.

The ability to evaluate valve performance via in-service diagnostics improves turnaround planning as the information gathered can be used to pinpoint valve maintenance that is necessary, as well as valves that are healthy.



Figure 8.4 Typical Spring-and-Diaphragm Actuator

An answer is to utilize smart, micro-processor-based valve instrumentation that evaluates the operating health of the control valve assembly while the valve is in service. Data is collected without intruding on normal process operations. The instrumentation

analyzes the information in real-time and provides maintenance recommendations for each valve operating problem that it identifies. ■

## 8.4 Service and Repair Parts

### 8.4.1 Recommended Spare Parts

Many companies will identify parts to be a recommended spare and provide a list of these parts for a given valve or actuator. This list is referred to as a “Recommended Spare Parts List” (RSPL). The list is based on the idea that certain components will wear. These components are the parts that do the work. In a valve, it could be the controlling element (i.e. plug/stem, cage, disk, ball, shaft, bearings, etc.) or the sealing components (i.e. seat, seal ring, balance seal, packing, etc.). In an actuator it could be the diaphragm, o-rings, bushings, etc.

The user should consider stocking the recommended spare parts and be available to service the valve when required. Since this could be a large investment and a considerable number of parts, several factors should be considered when deciding what to stock. The first thing to consider is the criticality of the valve or asset. Second, consider the risk of not having the unit function as intended for any given amount of time the asset is down. Then third, what is the availability of the parts needed, are they on-site or available from the manufacturer quickly.

The manufacturer may be able to provide a consolidated spares list where they have identified parts that could be used in multiple valves. Should you order parts to change the original construction due to process condition changes or other factors, please let your Emerson local business partner or sales office know which serial number you are

changing. This will allow us to update the serial card to reflect the new changes and help to ensure that the next time parts are ordered you will receive the correct parts and eliminate additional downtime.

### 8.4.2 Using Original Equipment Manufacturers (OEM) Parts

To maintain plant safety and integrity, as well as ensure the expected performance as the valve was designed, it is imperative that the service parts be from the OEM. The OEM or their authorized agent, is the only source who has the required specifications for the service parts.

### 8.4.3 Consider Upgrades for the Valve Trim

During the maintenance cycle, it is always important to examine parts and consider the need to upgraded. Considerations could be valve noise when operating, excessive trim damage, or if system operating parameters have changed from the original design. Many times changes to the valve trim can address these issues. ■

## 8.5 Actuator Maintenance

### 8.5.1 Spring-and-Diaphragm Actuators

Most pneumatic spring-and-diaphragm actuators (Figure 8.4) use a molded diaphragm. The molded diaphragm facilitates installation, provides a relatively uniform effective area throughout valve travel, and permits greater travel than could be possible with a flat-sheet diaphragm. Air to the diaphragm provides the actuator force in one direction and a spring will provide the force in the other direction. Since the air provides the force in only one direction, these actuators are often times

referred to a single-acting actuators.

### 8.5.2 Piston Actuators

Piston actuators utilize a piston with an o-ring or quad ring seal within a cylinder. Air can be supplied to both sides of the piston to provide the actuator force in either direction, these are said to be double-acting actuators. A piston actuator may also utilize a spring to replace the air on one side of the piston or to provide additional force with the air.

### 8.5.3 Stem Packing

Packing (Figure 8.5), which provides the pressure seal around the stem of a globe-style or angle-style valve body, should be replaced if leakage develops around the stem, or if the valve is completely disassembled for other maintenance or inspection. Before loosening packing nuts, make sure there is no pressure in the valve body.



Figure 8.5 Typical Valve Stem Packing Assemblies

Removing the packing without removing the actuator is difficult and is not recommended. Also, do not try to blow out the old packing rings by applying pressure to the lubricator hole in the bonnet. This can be dangerous and it does not work very well, as many packing arrangements have about half of the rings below the lubricator hole.

A better method is to remove the actuator and valve bonnet and pull out the stem. Push or drive the old packing out the top of the bonnet. Do not use the valve plug stem because the threads could sustain damage.

Clean the packing box. Inspect the stem for scratches or imperfections that could damage new packing. Check the trim and other parts as appropriate. After re-assembling, tighten body and bonnet bolting in a sequence similar to that described for flanges earlier in this chapter.

Slide new packing parts over the stem in proper sequence, being careful that the stem threads do not damage the packing rings. Adjust packing by following the manufacturer's instructions.

### 8.5.4 Seat Rings

Severe service conditions can damage the seating surface of the seat ring(s) so that the valve does not shut off adequately. Properly lapping the seating surfaces will improve shutoff if damage is not severe. For severe damage, replace the seat ring.

#### 8.5.4.1 Replacing Seat Rings

Follow the manufacturer's instructions. Seat rings could be threaded into the body, clamped (held in by a cage or other part), bolted in or hung (connected to the cage). For threaded seat rings, use a seat ring puller. Before trying to remove the seat ring(s), check to see if the ring has been tack-welded to the valve body. If so, cut away the weld.

On double-port bodies, one of the seat rings is smaller than the other. On direct-acting valves (push-down-to-close action), install the smaller ring in the body port farther from the bonnet before installing the larger ring. On reverse-acting valves (push-down-to-open action), install the smaller ring in

the body port closer to the bonnet before installing larger ring.

Remove all excess pipe compound after tightening the threaded seat ring. Spot weld a threaded seat ring in place to ensure that it does not loosen when required.

#### 8.5.4.2 Connections: Plug-to-Stem, Ball-to-Shaft, and Disk-to-Shaft

The connection between the controlling element (plug, ball, or disk) and the stem or shaft is critical for the safe and intended operation of the valve. This may require special requirements in the fit or assembly procedure. It is very important to follow all the OEM assembly instructions provided. Always consider purchasing plugs and stems, as a plug/stem assembly to ensure safe and proper performance. An improper connection can result in unstable control and excessive packing leakage.

#### 8.5.5 Bench Set

Bench set is initial compression placed on the actuator spring with a spring adjuster. For air-to-open valves, the lower bench set determines the amount of force available and the pressure required to begin valve-opening travel. For air-to-close valves, the lower bench set determines the pressure required to begin valve-closing travel. Seating force is determined by pressure applied minus bench set minus spring compression due to travel (Figure 8.6). Because of spring tolerances, there might be some variation in the spring angle. The bench set, when the valve is seated, requires the greatest accuracy. Refer to manufacturer's instructions for adjusting the spring.

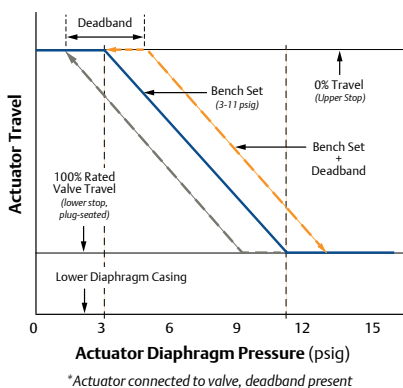

Figure 8.6 Bench Set Seating Force

#### 8.5.6 Valve Travel

Proper valve travel is essential to achieving proper control valve performance. Insufficient travel can cause the valve not to achieve the designed flow rate. Over travel can reduce the seat load from the actuator affecting shutoff and cause damage to the trim. Another problem attributed to over travel is that the plug can contact the bottom of the bonnet causing the stem to be pulled out of the plug. Sliding-stem valve travel is more critical than rotary valve travel. Therefore, greater attention to detail is crucial when setting sliding-stem valve travel. Refer to the manufacturers' instruction manual for the procedure to properly set valve travel. ■



# Chapter 9

## Standards and Approvals





## 9.1 Control Valve Standards

Numerous standards are applicable to control valves. International and global standards are becoming increasingly important for companies that participate in global markets. Following is a list of codes and standards that have been or will be important in the design and application of control valves.

### 9.1.1 American Petroleum Institute (API)

- Spec 6D, Specification for Pipeline Valves (Gate, Plug, Ball, and Check Valves)
- 598, Valve Inspection and Testing
- 607, Fire Test for Soft-Seated Quarter-Turn Valves
- 609, Lug- and Wafer-Type Butterfly Valves

### 9.1.2 American Society of Mechanical Engineers (ASME)

- B16.1, Cast Iron Pipe Flanges and Flanged Fittings
- B16.4, Gray Iron Threaded Fittings
- B16.5, Pipe Flanges and Flanged Fittings (for steel, nickel-based alloys, and other alloys)
- B16.10, Face-to-Face and End-to-End Dimensions of Valves (see ISA standards for dimensions for most control valves)
- B16.24, Cast Copper Alloy Pipe Flanges and Flanged Fittings
- B16.25, Butt Welded Ends
- B16.34, Valves - Flanged, Threaded, and Welding End
- B16.42, Ductile Iron Pipe Flanges and Flanged Fittings
- B16.47, Large Diameter Steel Flanges (NPS 26 through NPS 60)

### 9.1.3 European Committee for Standardization (CEN)

#### 9.1.3.1 European Industrial Valve Standards

- EN 19, Marking
- EN 558-1, Face-to-Face and Center-to-Face Dimensions of Metal Valves for Use in Flanged Pipe Systems - Part 1: PN-Designated Valves
- EN 558-2, Face-to-Face and Center-to-Face Dimensions of Metal Valves for Use in Flanged Pipe Systems - Part 2: Class-Designated Valves
- EN 593, Butterfly valves
- EN 736-1, Terminology - Part 1: Definition of Types of Valves
- EN 736-2, Terminology - Part 2: Definition of Components of Valves
- EN 736-3 Terminology - Part 3: Definition of Terms
- EN 1349, Industrial Process Control Valves
- EN 12266-1, Testing of Valves - Part 1: Tests, Test Procedures and Acceptance Criteria
- EN 12516-1, Shell Design Strength - Part 1: Tabulation Method for Steel Valves
- EN 12516-2, Shell Design Strength - Part 2: Calculation Method for Steel Valves
- EN 12516-3, Shell Design Strength - Part 3: Experimental Method
- EN 12627, Butt Weld-End Design
- EN 12760, Socket Weld-End Design
- EN 12982, End-to-End Dimensions for Butt Weld-End Valves

### 9.1.3.2 European Material Standards

- EN 10213-1, Technical conditions of delivery of steel castings for pressure purposes - Part 1: General
- EN 10213-2, Technical conditions of delivery of steel castings for pressure purposes - Part 2: Steel grades for use at room temperature and elevated temperatures
- EN 10213-3, Technical conditions of delivery of steel castings for pressure purposes - Part 3: Steel grades for use at low temperatures
- EN 10213-4, Technical conditions of delivery of steel castings for pressure purposes - Part 4: Austenitic and austeno-ferritic steel grades
- EN 10222-2, Technical conditions of delivery of steel forgings for pressure purposes - Part 2: Ferritic and martensitic steels for use at elevated temperatures
- EN 10222-3, Technical conditions of delivery of steel forgings for pressure purposes - Part 3: Nickel steel for low temperature
- EN 10222-4, Technical conditions of delivery of steel forgings for pressure purposes - Part 4: Fine grain steel
- EN 10222-5, Technical conditions of delivery of steel forgings for pressure purposes - Part 5: Austenitic martensitic and austeno-ferritic stainless steel

### 9.1.3.3 European Flange Standards

- EN 1092-1, Part 1: Steel flanges PN designated
- EN 1092-2, Part 2: Cast iron flanges PN designated
- EN 1759-1, Part 1: Steel flanges Class designated

### 9.1.4 Fluid Controls Institute (FCI)

- 70-2, Control Valve Seat Leakage

### 9.1.5 Instrument Society of America (ISA)

- S51.1, Process Instrumentation Terminology
- 75.01.01, Flow Equations for Sizing Control Valves
- 75.02.01, Control Valve Capacity Test Procedures
- 75.05.01, Terminology
- 75.07, Laboratory Measurement of Aerodynamic Noise Generated by Control Valves
- 75.08.01, Face-to-Face Dimensions for Integral Flanged Globe-Style Control Valve Bodies (ANSI Classes 125, 150, 250, 300, and 600)
- 75.08.02, Face-to-Face Dimensions for Flangeless Control Valves (ANSI Classes 150, 300, and 600)
- 75.08.03, Face-to-Face Dimensions for Socket Weld End and Screwed-End Globe-Style Control Valves (Classes 150, 300, 600, 900, 1500, and 2500)
- 75.08.04, Face-to-Face Dimensions for Butt Weld-End Globe-Style Control Valves (Class 4500)
- 75.08.05, Face-to-Face Dimensions for Butt Weld-End Globe-Style Control Valves (ANSI Classes 150, 300, 600, 900, 1500, and 2500)
- 75.08.06, Face-to-Face Dimensions for Flanged Globe-Style Control Valve Bodies (ANSI Classes 900, 1500, and 2500)
- 75.08.07, Face-to-Face Dimensions for Separable Flanged Globe-Style Control Valves (Classes 150, 300, and 600)
- 75.08.08, Face-to-Centerline Dimensions for Flanged Globe-Style Angle Control Valve Bodies (Classes 150, 300, and 600)
- 75.08.09, Face-to-Face Dimensions for Sliding-Stem Flangeless Control Valves (Classes 150, 300, and 600)

- 75.11.01, Inherent Flow Characteristic and Rangeability of Control Valves
- 75.13.01, Method of Evaluating the Performance of Positioners with Analog Input Signals
- 75.17, Control Valve Aerodynamic Noise Prediction
- 75.19.01, Hydrostatic Testing of Control Valves
- 75.26.01, Control Valve Diagnostic Data Acquisition and Reporting
- RP75.23, Considerations for Evaluating Control Valve Cavitation

### 9.1.6 International Electrotechnical Commission (IEC)

The majority of International Electrotechnical Commission (IEC) standards for control valves, several of which are based on ISA standards, have been re-published as EN standards and utilize an EN prefix. The IEC encourages national committees to adopt them and to withdraw any corresponding national standards. IEC standards are increasingly being applied by manufacturers and purchasers. Below is a list of IEC industrial process control valve standards (60534 series).

- 60534-1, Part 1: Control valve terminology and general considerations
- 60534-2-1, Part 2: Flow capacity - Section One: Sizing equations for incompressible fluid flow under installed conditions
- 60534-2-3, Part 2-3: Flow capacity - Section Three: Test procedures
- 60534-2-4, Part 2-4: Flow capacity - Section Four: Inherent flow characteristics and rangeability
- 60534-4, Part 4: Inspection and routine testing
- 60534-5, Part 5: Marking
- 60534-6-1, Part 6: Mounting details for attachment of positioners to

control valve actuators - Section 1: Positioner mounting on linear actuators

- 60534-6-2, Part 6-2: Mounting details for attachment of positioners to control valve actuators - Section 2: Positioner mounting on rotary actuators
- 60534-7, Part 7: Control valve data sheet
- 60534-8-1, Part 8-1: Noise considerations - Section One: Laboratory measurement of noise generated by aerodynamic flow through control valves
- 60534-8-2, Part 8-2: Noise considerations - Section Two: Laboratory measurement of noise generated by hydrodynamic flow through control valves
- 60534-8-3, Part 8-3: Noise considerations - Section Three: Control valve aerodynamic noise prediction method
- 60534-8-4, Part 8-4: Noise considerations - Section Four: Prediction of noise generated by hydrodynamic flow

### 9.1.7 Manufacturers Standardization Society (MSS)

- SP-6, Standard Finishes for Contact Faces of Pipe Flanges and Connecting End Flanges of Valves and Fittings
- SP-25, Standard Marking System for Valves, Fittings, Flanges and Unions
- SP-44, Steel Pipe Line Flanges
- SP-67, Butterfly Valves
- SP-68, High-Pressure Butterfly Valves with Offset Design
- SP-147, Quality Standard for Steel Castings used in Standard Class Steel Valves

### 9.1.8 NACE International

- NACE MR0175/ISO 15156, Petroleum and Natural Gas Industries

- Materials for Use in H<sub>2</sub>S-Containing Environments in Oil and Gas Production
- NACE MR0175-2002, Sulfide Stress Corrosion Cracking-Resistant Metallic Materials for Oil Field Equipment
- NACE MR0103/ISO 17945, Petroleum, Petrochemical and Natural Gas Industries—Metallic Materials Resistant to Sulfide Stress Cracking in Corrosive Petroleum Refining Environments
- NACE MR0103, Materials Resistant to Sulfide Stress Cracking in Corrosive Petroleum Refining Environments
- NACE RP0472, Methods and Controls to Prevent In-Service Environmental Cracking of Carbon Steel Weldments in Corrosive Petroleum Refining Environments ■

## 9.2 Product Approvals for Hazardous (Classified) Locations

**DISCLAIMER:** *The information contained in the following sections is to provide a broad overview of hazardous area classifications, types of protection techniques involved, and enclosure ratings. This information is for educational purposes and should not be used in place of any other source or governing documents.*

### 9.2.1 Hazardous Location Approvals and Definitions

Whenever control valve equipment, both mechanical and electrical, is to be used in an explosive gas atmosphere or in the presence of an explosive dust atmosphere, it is essential that an ignition hazard assessment be carried out. The assessment identifies the potential ignition sources that will be present or active by the equipment over its expected lifetime. Knowledge of these ignition sources is paramount in

order to minimize the risk of an explosion or fire from them.

**Explosive Gas Atmosphere:** Mixture of air, under atmospheric conditions, of flammable substances in the form of a gas or vapor, which, after ignition permits self-sustaining propagation.

**Explosive Dust Atmosphere:** Mixture of air, under atmospheric conditions, of flammable substances in the form of a dust, fiber, or flyings, which, after ignition permits self-sustaining propagation.

**Hazardous Location (or area):** An area in which an explosive gas atmosphere or explosive dust atmosphere (or both) is expected to be present in sufficient quantities as to require special precautions for the construction, installation, and use of the equipment.

**Approval Agency:** An organization, company, or bureau who has the authority to grant, authorize, or make an attestation to certain facts, usually in the form a certificate.

**Certification Schemes:** A group or consensus of approval agencies who agree to operate under a unified system of rules and regulations. Examples include, the European Union, Eurasia Economic Union, IECEx Scheme, Gulf States Organization, etc. ■

## 9.3 Classification Systems

There are two classification systems used to classify hazardous areas, the Class/Division System and the Zone System. The Class/Division system is generally used in the United States and Canada, however new installations may use the Zone system. The rest of the world generally uses the Zone system.

### 9.3.1 Class/Division System

Hazardous locations (or area) per the Class/Division System are classified

according to the class, division, and group.

**Class:** The class defines the general nature of the hazardous material in the surrounding atmosphere.

- **Class I:** Locations in which flammable gases or vapors are, or may be, present in the air in quantities sufficient to produce explosive or ignitable mixtures.
- **Class II:** Locations that are hazardous because of the presence of combustible dusts.
- **Class III:** Locations in which easily ignitable fibers or flyings may be present, but not likely to be in suspension in air in sufficient quantities to produce ignitable mixtures.

**Division:** The division defines the probability (likelihood) of hazardous material being present in an ignitable concentration in the surrounding atmosphere.

- **Division 1:** Locations in which ignitable concentrations of the hazardous material exist under normal operating conditions (continuously, intermittently, or periodically) or frequently because of repair, maintenance operations, or because of leakage. A high probability.
- **Division 2:** Locations that are presumed to be hazardous only in an abnormal situation. A low probability.

**Group:** The group defines the explosive characteristic of the air mixtures of gases, vapors, or dust of the specific material involved. Groups A, B, C, and D apply to Class I whereas Groups E, F, and G apply to Class II.

- **Group A:** Acetylene.
- **Group B:** Atmospheres whose maximum experimental safe gap (MESG) value is less than or equal to 0.45mm or a minimum igniting current ratio (MIC ratio) less than or equal to 0.40. Examples include: hydrogen, butadiene, ethylene oxide, acrolein, and formaldehyde gas.

- **Group C:** Atmospheres whose experimental safe gap (MESG) value is greater than 0.45mm but less than or equal to 0.75mm or minimum igniting current ratio (MIC ratio) greater than 0.40 but less than or equal to 0.80. Examples include: ethylene, diethyl ether, methyl ether, propyl ether, nitromethane, and hydrazine.

- **Group D:** Atmospheres whose experimental safe gap (MESG) value is greater than 0.75mm or a minimum igniting current ratio (MIC ratio) greater than 0.80. Examples include: propane, natural gas, methane, ammonia, benzene, acetone, and butane.

- **Group E:** Atmospheres containing combustible metallic dusts, such as aluminum, magnesium, and their commercial alloys.

- **Group F:** Atmospheres containing combustible carbonaceous dusts with 8% or more trapped volatiles, such as carbon black, coal, or coke dust.

- **Group G:** Atmospheres containing combustible dusts not included in Group E or Group F. Typical dusts include flour, starch, grain, wood, plastic, and chemicals.

All electrical equipment must be tested, marked, and approved for the particular hazardous location it is intended to be used in, e.g. class, division, and group, in the Class/Division System. There are exceptions to this rule, which can be found in the wiring practices of the National Electric Code (NEC) or Canadian Electric Code (CEC).

### 9.3.2 Zone System

Hazardous locations per the Zone System are classified according to the frequency of the occurrence and the duration of an explosive atmosphere. Zones 0, 1, and 2 pertain to explosive gas atmospheres, whereas Zones 20, 21, and 22 pertain to explosive dust

atmospheres.

- **Zone 0:** An explosive gas atmosphere that is present continuously, or for long periods, or frequently.
- **Zone 1:** An explosive gas atmosphere that is likely to occur periodically or occasionally in normal operation.
- **Zone 2:** An explosive gas atmosphere that is not likely to occur in normal operation, but if does occur, it will exist for a short period only.
- **Zone 20:** An explosive dust atmosphere that is present continuously, or for long periods, or frequently.
- **Zone 21:** An explosive dust atmosphere that is likely to occur periodically or occasionally in normal operation.
- **Zone 22:** An explosive dust atmosphere that is not likely to occur in normal operation, but if does occur, it will exist for a short period only.

It is important to note that the assignment of a zone classification number only addresses the likelihood of an explosive environment. It does not specify the explosive nature or the material characteristics of the specific gas, vapors, or dusts involved. Ideally, all equipment would be placed outside of these zones, but that is not realistic. Thus equipment intended for use in these zones is tested, marked, and approved such that the explosive nature and material characteristics are fully considered. This is done by dividing the equipment into groups, subgroups, the type of protection used, the level of protection used, assignment of an equipment protection level (EPL), and a temperature code, discussed next.

### 9.3.3 Equipment Groups

Equipment is organized into the following groups according to the following definitions.

- **Group I:** Equipment that is intended for use in mines susceptible to firedamp.
- **Group II:** Equipment that is intended for use in explosive gas atmospheres other than mines.
- **Group III:** Equipment that is intended for use in explosive dust atmospheres.

### 9.3.4 Equipment Subgroups

Equipment Group I has no subgroup. Only equipment Group II and Group III are subdivided further according to the explosive nature of the gas atmosphere and dust atmospheres, respectively, for which it is intended to be used in. The group number is followed by either the letter A, B, or C according to the below definitions.

#### 9.3.4.1 Group II (Commonly referred to as the “Gas Group”)

- **IIA:** Atmospheres whose experimental safe gap (MESG) value is greater than or equal to 0.9mm or a minimum igniting current ratio (MIC ratio) greater than 0.80. Examples include: propane
- **IIB:** Atmospheres whose experimental safe gap (MESG) value is greater than 0.5mm but less than 0.9mm or a minimum igniting current ratio (MIC ratio) greater than or equal to 0.45 but less than or equal to 0.80. Examples include: ethylene
- **IIC:** Atmospheres whose experimental safe gap (MESG) value is less than or equal to 0.5mm or a minimum igniting current ratio (MIC ratio) less than 0.45. Examples include: hydrogen

#### 9.3.4.2 Group III (Commonly referred to as the “Dust Group”)

- **IIIA:** Atmospheres containing combustible flyings or fibers including solid particles that are

generally greater than 500um in nominal size. Examples include: rayon, cotton, sisal, jute, hemp, cocoa fiber.

- **IIIB:** Atmospheres containing non-conductive dust whose electrical resistivity is greater than 103 Ωm. Examples include: nylon, wheat flour, charcoal (activated), coal, coke, glisonite
- **IIIC:** Atmospheres containing conductive dust whose electrical resistivity is less than or equal to 103 Ωm. Examples include: aluminum, magnesium

Equipment marked as IIB is suitable for applications requiring Group IIA equipment. Similarly, equipment marked as IIC is suitable for applications requiring Group IIB or Group IIA equipment. Likewise, equipment marked as IIIB is suitable for applications requiring Group IIIA equipment. Similarly, equipment marked as IIIC is suitable for applications requiring Group IIIB or Group IIIA equipment. See Figure 9.1.

	Equipment Grouping	Suitable Applications
Gas	IIC	IIC, IIB, IIA
	IIB	IIB, IIA
	IIA	IIA
Dust	IIC	IIC, IIB, IIA
	IIB	IIB, IIA
	IIA	IIA

Figure 9.1 Equipment Groups

### 9.3.5 Type of Protection

#### 9.3.5.1 Electrical Equipment

There are many techniques and methods which can be applied to electrical equipment in order to avoid ignition of the surrounding explosive atmosphere. Nearly all of these techniques and

methods have been given a specific name along with a lower case letter which signify its type of protection in its marking plate. It is important to note that not all types of protections are suitable for both gas and dust atmospheres. The type of protection techniques and methods, by name and its assigned letter, along with which explosive atmosphere they can be used in (denoted in parenthesis) are as follows:

- **Intrinsic Safety – Ex i (gas and dust):** A type of protection based on the restriction of electrical energy within the equipment and of interconnecting wiring exposed to the explosive atmosphere (gas or dust) to a level below that which can cause ignition by either sparking or heating effects. Equipment is constructed so that the non-intrinsically-safe circuits cannot adversely affect the intrinsically-safe circuits.
- **Flame-Proof Enclosure – Ex d (gas):** A type of protection in which the parts capable of igniting an explosive gas atmosphere are provided with an enclosure which can withstand the pressure developed during an internal explosion of an explosive mixture and which prevents the transmission of the explosion to the explosive gas atmosphere surrounding the enclosure.
- **Encapsulation – Ex m (gas and dust):** A type of protection in which the parts capable of igniting an explosive atmosphere (gas or dust) by either sparking or heating are enclosed in a compound or other non-metallic enclosure with adhesion in such a way that the explosive atmosphere cannot be ignited under operating or installation conditions.
- **Increased Safety – Ex e (gas):** A type of protection applied to electrical equipment in which additional measures are applied so as to give increased security against the

possibility of excessive temperatures and of the occurrence of arcs and sparks in normal service or under specified abnormal conditions.

- **Type n – Ex n (gas):** A type of protection applied to electrical equipment such that in normal operation and in certain specified abnormal conditions, it is not capable of igniting a surrounding explosive gas atmosphere.
- **Pressurization – Ex p (gas and dust):** A type of protection of guarding against the ingress of the external explosive atmosphere into an enclosure by maintaining a protective gas therein at a pressure above that of the external atmosphere.
- **Oil Immersion – Ex o (gas):** A type of protection in which the electrical equipment or parts of the electrical equipment are immersed in a protective liquid in such a way that an explosive gas atmosphere which may be above the liquid or outside the enclosure cannot be ignited.
- **Powder Filling – Ex q (gas):** A type of protection in which the parts capable of igniting an explosive gas atmosphere are fixed in position and completely surrounded by filling material to prevent ignition of an external explosive gas atmosphere.
- **Enclosure – Ex t (dust):** A type of protection whereby all electrical equipment is protected by an enclosure to avoid ignition of a dust layer or cloud and to limit surface temperatures.
- **Special Protection – Ex s (gas and dust):** A type of protection that allows for the design of a product that cannot comply in full with other recognized types of protection or where the standards for the recognized types of protection do not cover the required operating conditions.

### 9.3.5.2 Non-Electrical Equipment

Most electrical equipment often

contains effective ignition sources that must be dealt with by one of the protection methods previously described. However, this is not true for most mechanical equipment. In fact, normal operation of most mechanical equipment within its design parameters will not lead to ignition of an explosive atmosphere. In situations where malfunctions are considered, much of the mechanical equipment can be designed such that these malfunctions do not become an ignition source by a proper choice of well-trying constructional measures.

The following types of ignition protection measures for non-electrical equipment, by name and its assigned letter, have been recognized.

- **Flow Restricting Enclosure – Ex fr:**  
A type of ignition protection where effective sealing and closely matched joints can reduce the ingress of the explosive atmosphere to form inside the enclosure. Pressure differentials and changes in temperature need to be taken into account.
- **Flame-Proof Enclosure – Ex d:** A type of ignition protection in which the parts capable of igniting an explosive gas atmosphere are provided with an enclosure which can withstand the pressure developed during an internal explosion of an explosive mixture and which prevents the transmission of the explosion to the explosive gas atmosphere surrounding the enclosure.
- **Constructional Safety – Ex c:** A type of ignition protection in which constructional measures are applied so as to protect against the possibility of ignition from hot surfaces, sparks, and adiabatic compression generated by moving parts, including malfunctions.
- **Control of Ignition Sources – Ex b:**  
A type of ignition protection whereby integral sensors detect an impending



operation of the equipment likely to cause an ignition and therefore initiate control measures before a potential ignition source becomes an effective ignition source.

- **Pressurization – Ex p:** A type of ignition protection of guarding against the ingress of the external explosive atmosphere into an enclosure by maintaining a protective gas therein at a pressure above that of the external atmosphere.
- **Liquid Immersion – Ex k:** A type of ignition protection where ignition sources are rendered inactive by immersion in a liquid or by the constant moistening using a liquid film.

### 9.3.6 Level of Protection

Depending upon the type of protection employed by the equipment, a level of protection letter (or sub-letter) of either an a, b, c, or no letter at all will be assigned. The level of protection letter, if assigned, immediately follows the type of protection letter and is referred to as the equipment's level of protection for that specific type of protection being used. The level of protection letter denotes the likelihood of the equipment becoming a source of ignition. Again, it is important to emphasize that the level of protection (a, b, c, or none) assigned depends strictly upon the type of protection being applied to the equipment. The reason for this is because not all types of protection can be made to afford a very high or even a high level of protection which will not become a source of ignition in rare or expected malfunctions. Additionally, the level of protection assigned correlates very closely to the equipment's overall EPL rating (discussed later).

Although not explicitly defined the level of protection letter can be generalized as follows:

- **a:** A very high level of protection.

- **b:** A high level of protection.
- **c or none:** An enhanced level of protection.

The assignment of a level of protection allowed for a given type of protection for electrical equipment is as follows:

- **Ex i – Intrinsic Safety:** Ex ia, Ex ib, Ex ic
- **Ex d – Flame-Proof:** Ex da, Ex db, Ex dc
- **Ex m – Encapsulation:** Ex ma, Ex mb, Ex mc
- **Ex e – Increased Safety:** Ex eb, Ex ec
- **Ex n – Type n:** A level of protection letter is not assigned for this type of protection. This type of protection is only suitable for Zone 2 locations
- **Ex p – Pressurization:** Ex pxb, Ex pyb, Ex pzc
- **Ex o – Oil Immersion:** Ex ob, Ex oc
- **Ex q – Powder Filling:** A level of protection letter is not assigned for this type of protection. This type of protection is only suitable for Zone 1 and Zone 2 locations.
- **Ex t – Dust Enclosure:** Ex ta, Ex tb, Ex tc
- **Ex s – Special Protection:** Ex sa, Ex sb, Ex sc

### 9.3.7 Equipment Protection Level (EPL)

An EPL rating is an equipment assignment based upon its likelihood of becoming a source of ignition in either an explosive gas atmosphere or an explosive dust atmosphere, including mines.

- **EPL Ma:** Equipment for installation in mines susceptible to firedamp, having a very high level of protection which is unlikely to become an ignition source in normal operation, during expected malfunctions, or during rare malfunctions.
- **EPL Mb:** Equipment for installation in mines susceptible to firedamp,

having a high level of protection which is unlikely to become an ignition source in normal operation or during expected malfunctions.

- **EPL Ga:** Equipment for explosive gas atmospheres having a very high level of protection which is not a source of ignition in normal operation, during expected malfunctions, or during rare malfunctions.
- **EPL Gb:** Equipment for explosive gas atmospheres having a high level of protection which is not a source of ignition in normal operation or during expected malfunctions.
- **EPL Gc:** Equipment for explosive gas atmospheres having an enhanced level of protection which is not a source of ignition in normal operation and may have some additional protection to ensure that it remains inactive as an ignition source.
- **EPL Da:** Equipment for explosive dust atmospheres having a very high level of protection which is not a source of ignition in normal operation, during expected malfunctions, or during rare malfunctions.
- **EPL Db:** Equipment for explosive dust atmospheres have a high level of protection which is not a source of ignition in normal operation or during expected malfunctions.
- **EPL Dc:** Equipment for explosive dust atmospheres having an enhanced level of protection which is not a source of ignition in normal operation and may have some additional protection to ensure that it remains inactive as an ignition source.

The default relationship between zones and equipment protection levels (EPLs) can be summarized in the Figures 9.2 and 9.3. ■

Zone	Equipment Protection Level (EPL)
0	Ga
1	Ga or Gb
2	Ga or Gb or Gc
20	Da
21	Da or Db
22	Da or Db or Dc

Figure 9.2 Zones vs. Equipment Protection Levels

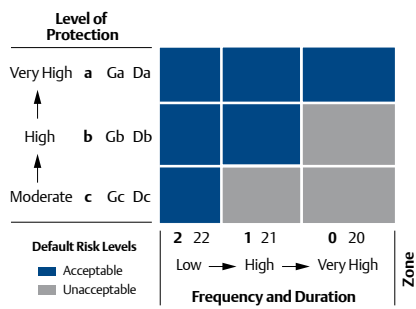

Figure 9.3 Zones vs. Equipment Protection Levels

## 9.4 Temperature Code

If an explosive gas atmosphere comes into contact with a significantly hot surface, an ignition is likely to take place in the absence of a spark or flame being present. The conditions under which a hot surface will ignite the explosive gas atmosphere depends on its surface area, temperature, and the specific gas group involved. For ease of classification and marking purposes, temperature codes are defined in Figure 9.4.

T Code	Maximum Surface Temperature
T1	450°C (842°F)
T2	300°C (572°F)
T3	200°C (392°F)
T4	135°C (275°F)
T5	100°C (212°F)
T6	85°C (185°F)

Figure 9.4 Temperature Codes

Equipment that has been tested receives a temperature code that indicates the maximum surface temperature attained by the equipment. Regardless of which classification system is being used, the maximum surface temperature may be internal or external to the equipment which is determined by the type of protection being employed.

Explosive dust atmospheres have very different characteristics than gas atmospheres, however they can also be ignited by a hot surface. The additional constraints for ignition of an explosive dust atmosphere include, but are not limited to, the atmospheric dust concentration, dust dispersion, thickness of dust layers, etc. Equipment for explosive dust atmospheres are marked with the maximum surface temperature on its marking plate and not with a temperature code.

For process control equipment (such as valves), the maximum surface temperature greatly depends upon the fluid, the ambient air temperature, the choice of materials used in its construction, and its physical geometry. In most cases, only the end user will know the true operating conditions that the equipment will be subjected too. Therefore, such equipment is marked 'TX' which signifies to the end user that the maximum surface temperature of the equipment is dependent upon operating conditions. Adding heat to

any process pipeline which could enter an explosive atmosphere must be carefully considered and evaluated. ■

## 9.5 Nomenclature

### 9.5.1 Class/Division System

In the Class/Division System there is no formal name or term used to describe a given class or division rating. However, the industry widely uses the following terms to associate them to a given class or division rating;

- Explosion-Proof – Class I Division 1
- Non-Incendive – Class I Division 2
- Dust Ignition-Proof – Class II Division 1
- IS Equipment (Intrinsically-Safe equipment) – Class I Division 1 or Class I, II, III Division 1

Intrinsically-safe equipment (or apparatus) is unique in that energy is limited and can be approved for just gas atmospheres or for both gas and dust atmospheres. Intrinsically-safe equipment is always evaluated as being in a Division 1 location.

### 9.5.2 Zone System

In the Zone System, a lower case letter represents the type of protection that has been applied to the equipment. The name associated to a given type of protection is well defined. Refer to the type of protection for a description.

### 9.5.3 Wiring Practices

It cannot be emphasized enough that both the equipment and its associated wiring practice during installation are critical in preventing explosions in hazardous locations. The following wiring practices are widely used.

- National Electric Code (NEC) – U.S.
  - Articles 500 to 504 address installations that use the Class/

- Division System
  - Articles 505 to 506 address installations that use the Zone System
- Canadian Electric Code (CEC) – Canada
  - Section 18 address installations that use the Zone System
  - Section J address installations use the Class/Division System
- IEC 60079-14 (Electrical installations design, selection, and erection) – Worldwide
  - Addresses electrical installations per the Zone System

### 9.5.4 European Union (EU) – ATEX Directive 2014/34/EU

Per the ATEX Directive, there exist only two equipment groups, three equipment categories, and two explosive atmosphere environments.

#### Group

- **Group I:** Equipment for use in underground mines susceptible to firedamp
- **Group II:** Equipment for use in places other than mines.

#### Category

- **Category 1:** Equipment designed to ensure a very high level of protection
- **Category 2:** Equipment designed to ensure a high level of protection
- **Category 3:** Equipment designed to ensure a normal (moderate or enhanced) level of protection

#### Environment

- **G:** Equipment intended for use in explosive gas atmospheres.
- **D:** Equipment intended for use in explosive dust atmospheres.

For ATEX approved equipment the following additional ATEX marking shall appear on the equipment in addition to

the general marking requirements.

- Explosion protection symbol (Ex)
- Equipment Group – I or II
- Equipment Category – 1 or 2 or 3
- Environment – G or D

Figure 9.5 illustrates the relationship between the IEC equipment group ratings versus the ATEX Directive’s definition of equipment group ratings.

### 9.5.5 Marking Examples

#### Class/Division

- **CL I DIV 1 GP BCD:** Explosion-Proof approval for Class I Division 1 for Groups B, C, D
- **CL 1 DIV 2 GP ABCD:** Non-Incendive approval for Class I Division 2 for Groups A, B, C, D

	IEC Equipment Ratings		ATEX Equipment Ratings	
	Per IEC 60079 Series		Directive 2014/34/EU	
	EPL	Group	Equipment Group	Equipment Category & Environment
Mines	Ma	I	I	M1
	Mb			M2
Gas	Ga	II	II	1G
	Gb			2G
	Gc			3G
Dust	Da	III	II	1D
	Db			2D
	Dc			3D

Figure 9.5 IEC Ratings vs. ATEX Ratings

- **I.S. CL I DIV 1 GP ABCD:** Intrinsically-safe approval (USA) for gas atmospheres of Groups A, B, C, D
- **I.S. CL I,II,III DIV 1 GP ABCDEFG:** Intrinsically-safe approval (USA) for gas and dust atmospheres for all Groups
- **Ex ia INTRINSICALLY SAFE CL I DIV 1 GP CD:** Intrinsically-safe approval

(Canada) for gas atmospheres of Groups C, D

- **CL I,II,III DIV 2 GP ABCDEFG:** An approval that is only good for Division 2 locations both gas and dust

### Zone

- **Class I Zone 0 AEx ia IIB T4 Ga:** A USA Zone approval utilizing intrinsic safety with a very high level of protection for gas group IIB whose temperature code is T4 with an EPL rating of Ga.
- **Ex db IIC T5 Gb with II 2 G:** An ATEX approval utilizing flame-proof techniques with I high level of protection suitable for gas group IIC whose temperature code is T5 with an EPL of Gb.
- **Ex ia IIC T6 Ga:** An intrinsically-safe approval with a very high level of protection suitable for gas group IIC with a temperature code of T6 and an EPL of Ga.
- **Ex e mb IIB T4 Gb:** Equipment that utilizes increased safety and encapsulation with a high level of protection suitable for gas group IIB with a temperature code of T4 and an EPL of Gb. ■

## 9.6 Protection Techniques and Methods

With regards to the various protection techniques and methods used in equipment, the following two points are very important:

- Each protection technique and method is unique for either a gas atmosphere, a dust atmosphere or both.
- Each protection technique and method differs on the level of protection it can provide, e.g. very high, high, or enhanced.

### 9.6.1 Explosion-Proof or Flame-Proof Technique

*Suitable for gas atmospheres – Class I Division 1 (or 2), Zone 1 (or 2).*

This type of protection utilizes an enclosure capable of withstanding an explosive gas or vapor within it and prevents the transmission of ignitable hot gases outside the enclosure, which may be surrounded by an explosive gas atmosphere. In simple terms, contain the explosion within the enclosure and prevent ignition of the explosive gas atmosphere outside it.

#### Advantages

- Users are familiar with the technique and understand its principles and applications.
- Sturdy housing design provides protection to the internal components of the equipment.
- An explosion-proof housing is usually weatherproof as well.

#### Disadvantages

- Circuits must be de-energized or the location rendered non-hazardous before housing covers can be removed.
- Opening of a cover in a hazardous area voids all protection.
- Generally, this technique requires use of heavy bolted or screwed enclosures.
- Extended ambient temperature ranges require additional safety factors that the design may not be able to accommodate.
- To maintain the explosion-proof rating and reduce pressure piling, conduit seals or explosion-proof cabling is necessary.

### 9.6.2 Intrinsically-Safe Technique

*Suitable for gas or dust atmospheres – Class I Division 1 (or Class II,III Division 1), Zone 0 (or 1 or 2), Zone 20 (or 21 or 22).*

This type of protection operates by limiting the release of electrical energy or thermal energy available in the circuits and equipment to levels that are incapable of igniting a specific explosive atmosphere. Equipment is designed for specific gas and dust groups, along with varying levels of protection, which considers normal and abnormal conditions (except for class/division equipment which is always evaluated as Division 1).

### Advantages

- Heavy protection of the field wiring is not necessary and offers lower cost.
- Greater flexibility is offered since this technique permits simple components, such as switches, contact closures, thermocouples, RTDs, and other non-energy storing instruments to be used without certification.
- Field maintenance and repair is easier. There is no need to remove power before adjustment or calibration of the field equipment. The system remains safe even if the equipment is damaged because the energy level is too low to ignite the most easily ignitable mixture. Diagnostic and calibration equipment must have the appropriate approvals for the hazardous area.

### Disadvantages

- This technique requires the use of an intrinsically-safe barrier to limit the voltage, current, and power between the hazardous area and safe area to avoid development of sparks or hot spots in the circuitry of the equipment.
- Users need to be comfortable with this technique and the wiring practices associated with it.
- High energy consumption applications are not applicable to this technique because the energy is limited at the source (barrier). This technique is limited to low power

applications such as DC circuits, electro-pneumatic positioners, electro-pneumatic converters, transducers, etc.

### 9.6.3 Non-Incendive or Type n Technique

*Suitable for gas atmospheres – Class I Division 2, Zone 2.*

A type of protection in which the equipment is incapable, under normal operating conditions, of causing an ignition due to any arcs, sparks, or thermal effects within the equipment. This type of protection also applies to equipment which does contain arcs or sparks, provided they are protected by one of the ways specified in the standard.

### Advantages

- Equipment is designed such that it does not produce any arcs or sparks, nor does it develop any high temperatures.
- Equipment is generally lower cost than the other types of protections because there is no need for explosion-proof housings or energy limiting barriers.
- For Class I Division 2 applications, if connected to a non-incendive circuit, the user is allowed to use any ordinary wiring practice.

### Disadvantages

- This technique is limited to Division 2 or Zone 2 applications.
- For Class I Division 2 applications, the field wiring must be well protected.
- Non-incendive circuits are an additional expense to the end user because it must limit the energy to safe levels in the event of an open, short, or ground of the field wiring.

### 9.6.4 Increased Safety

*Suitable for gas environments – Zone 1 (or 2).*

This type of protection applies to electrical equipment or Ex components in which additional measures are applied to give increased security against the possibility of excessive temperatures and against the occurrence of arcs and sparks. This protection is only suitable for equipment that does not contain any incandive devices (arcs or sparks) during normal operation. Examples include: terminal boxes, junction boxes, etc. This is commonly used in conjunction with flame-proof approved equipment.

### Advantages

- Increased safety enclosures provide at least an IP54 enclosure rating.
- Installation and maintenance are easier than flame-proof enclosures.
- This technique offers significantly reduced wiring costs over flame-proof enclosures.

### Disadvantages

- This technique is limited in the apparatus for which it can be used. It is normally used for apparatuses, such as terminal boxes and compartments.

### 9.6.5 Dust Ignition-Proof or Enclosure Dust-Proof

*Suitable for dust atmospheres – Class II Division 1 (or 2), Zone 20 (or 21 or 22).*

This type of protection results in an enclosure that will exclude ignitable amounts of dust and will not permit arcs, sparks, or heat otherwise generated inside the enclosure to cause an ignition of the exterior dust atmosphere in atmospheric suspension or in layers.

### Advantages

- Installation does not require a barrier, whereas intrinsically-safe equipment for dust does.
- Can be used in high-energy applications.

### Disadvantages

- Certain apparatuses may be such that intrinsic safety is the only option. ■

## 9.7 Enclosure Ratings

Enclosures of electrical equipment are often tested to determine their ability to prevent the ingress of liquids and dusts. The most widely used enclosure rating standards are NEMA 250 and UL 50 (United States), CSA C22.2 No. 94 (Canada), and IEC 60529 (worldwide). Standard UL 50 and CSA C22.2 No. 94 closely parallels standard NEMA 250 with regards to ratings.

Some of the more common enclosure ratings as defined in NEMA 250 for unclassified locations (general locations) are as follows:

- **Type 3 – Indoor or outdoor enclosure, rain-tight, dust-tight, ice-resistant:** Intended for indoor or outdoor use primarily to provide a degree of protection against falling dirt, windblown dust, rain, sleet, snow, and damage from external ice formation on the enclosure.
- **Type 3X – Indoor or outdoor enclosure, rain-tight, dust-tight, ice-resistant, corrosion-resistant:** Intended for indoor or outdoor use primarily to provide a degree of protection against falling dirt, windblown dust, rain, sleet, snow, damage from external ice formation on the enclosure, and corrosion.
- **Type 3R – Indoor or outdoor enclosure, rainproof (or rain-tight), ice-resistant:** Intended for indoor or outdoor use primarily to provide a degree of protection against falling dirt, rain, sleet, snow, and damage from external ice formation on the enclosure.
- **Type 3RX – Indoor or outdoor enclosure, rainproof (or rain-tight), ice-resistant, corrosion-**

**resistant:** Intended for indoor or outdoor use primarily to provide a degree of protection against falling dirt, rain, sleet, snow, damage from external ice formation on the enclosure, and corrosion.

- **Type 3S – Indoor or outdoor enclosure, rain-tight, dust-tight, ice-proof:** Intended for indoor or outdoor use primarily to provide a degree of protection against falling dirt, windblown dust, rain, sleet, snow, and to provide for operation of external mechanisms when ice laden.
- **Type 3SX – Indoor or outdoor enclosure, rain-tight, dust-tight, ice-proof, corrosion-resistant:** Intended for indoor or outdoor use primarily to provide a degree of protection against falling dirt, windblown dust, rain, sleet, snow, and to provide for operation of external mechanisms when ice laden, and corrosion.
- **Type 4 – Indoor or outdoor enclosure, rain-tight, water-tight, dust-tight, ice-resistant:** Intended for indoor or outdoor use primarily to provide a degree of protection against falling dirt, windblown dust, rain, sleet, snow, splashing water, hose-directed water, and damage from external ice formations on the enclosure.
- **Type 4X – Indoor or outdoor enclosure, rain-tight, water-tight, dust-tight, ice-resistant, corrosion-resistant:** Intended for indoor or outdoor use primarily to provide a degree of protection against falling dirt, windblown dust, rain, sleet, snow, splashing water, hose-directed water, damage from external ice formations on the enclosure, and corrosion.

NEMA 250 also defines enclosure ratings for classified locations as follows:

- **Type 7 – Indoor enclosure, Class I Division 1 approved:** Intended for indoor use in explosion-proof

applications.

- **Type 8 – Indoor or outdoor enclosure, Class I Division 1 approved, rain-tight, ice-resistant:** Intended for indoor or outdoor use in explosion-proof applications and which provides a degree of protection from rain, sleet, snow, and damaged from external ice formation on the enclosure.
- **Type 9 – Indoor enclosure, Class II Division 1 approved:** Intended for indoor use in dust ignition-proof applications.

The NEMA ratings for classified locations are often misunderstood. It should be apparent that a NEMA 7 or NEMA 8 rating is essentially the same as that for Class I Division 1. A NEMA 9 rating is essentially the same as that for Class II Division 1. Per the NEC and CEC, all equipment must be appropriately marked for the class, division, and group that it has obtained. Therefore, a product marked as NEMA 7, NEMA 8, or NEMA 9 alone without any additional marking identifying its class, division, or group is unacceptable and not allowed. Most approval agencies discourage the use of applying NEMA 7, NEMA 8, or NEMA 9 for this very reason and do not allow it.

Enclosures that are tested to IEC 60529 are allowed to carry an Ingress Protection (IP) code that specifies its rating. The IP code consists of the letters “IP” followed by two characteristic numerals the degree of conformity obtained. The first numeral indicates the degree of protection against human contact with or approach to live parts, human contact with moving parts inside the enclosure, and ingress of solid foreign body objects. The second numeral indicates the degree of protection provided by the enclosure against the ingress of water. See Figure 9.7 for more information. ■



Degree of Protection Against the Following Conditions		Test Clause	Type of Enclosure							
			3	3X	3R	3RX	3S	3SX	4	4X
General	Access to hazardous parts	5.2	X	X	X	X	X	X	X	X
	Falling dirt	5.5.2	X	X	X	X	X	X	X	X
Ingress of Solid Foreign Objects	Windblown dust, lint fibers	5.5.1	X	X			X	X	X	X
	Dripping and light splashing	5.3	X	X	X	X	X	X	X	X
Ingress of Water	Rain, snow, sleet, ice*	5.4	X	X	X	X	X	X	X	X
	Rain, snow, sleet, ice**	5.6					X	X		
	Hose-directed and splashing water	5.7							X	X
Additional Protection	Corrosion	5.9 & 5.10		X		X		X		X

\* External operating mechanisms are not required to be operable when the enclosure is ice covered.  
\*\* External operating mechanisms are operable when the enclosure is ice covered.

Figure 9.6 Explanation of Enclosure Ratings

First Numeral Protection Against Solid Bodies	Second Numeral Protection Against Liquid
0 - No protection	0 - No protection
1 - Objects greater than 50 mm	1 - Vertically dripping water
2 - Objects greater than 12.5 mm	2 - Angled dripping water (75 to 90 degrees)
3 - Objects greater than 2.5 mm	3 - Sprayed water
4 - Objects greater than 1.0 mm	4 - Splashed water
5 - Dust-protected	5 - Jetting
6 - Dust-tight	6 - Powerful jetting
	7 - Temporary immersion
	8 - Permanent immersion
	9 - High-pressure and temperature water jet

Figure 9.7 Description of Ingress Protection Numerals

# Chapter 10

## Isolation Valves

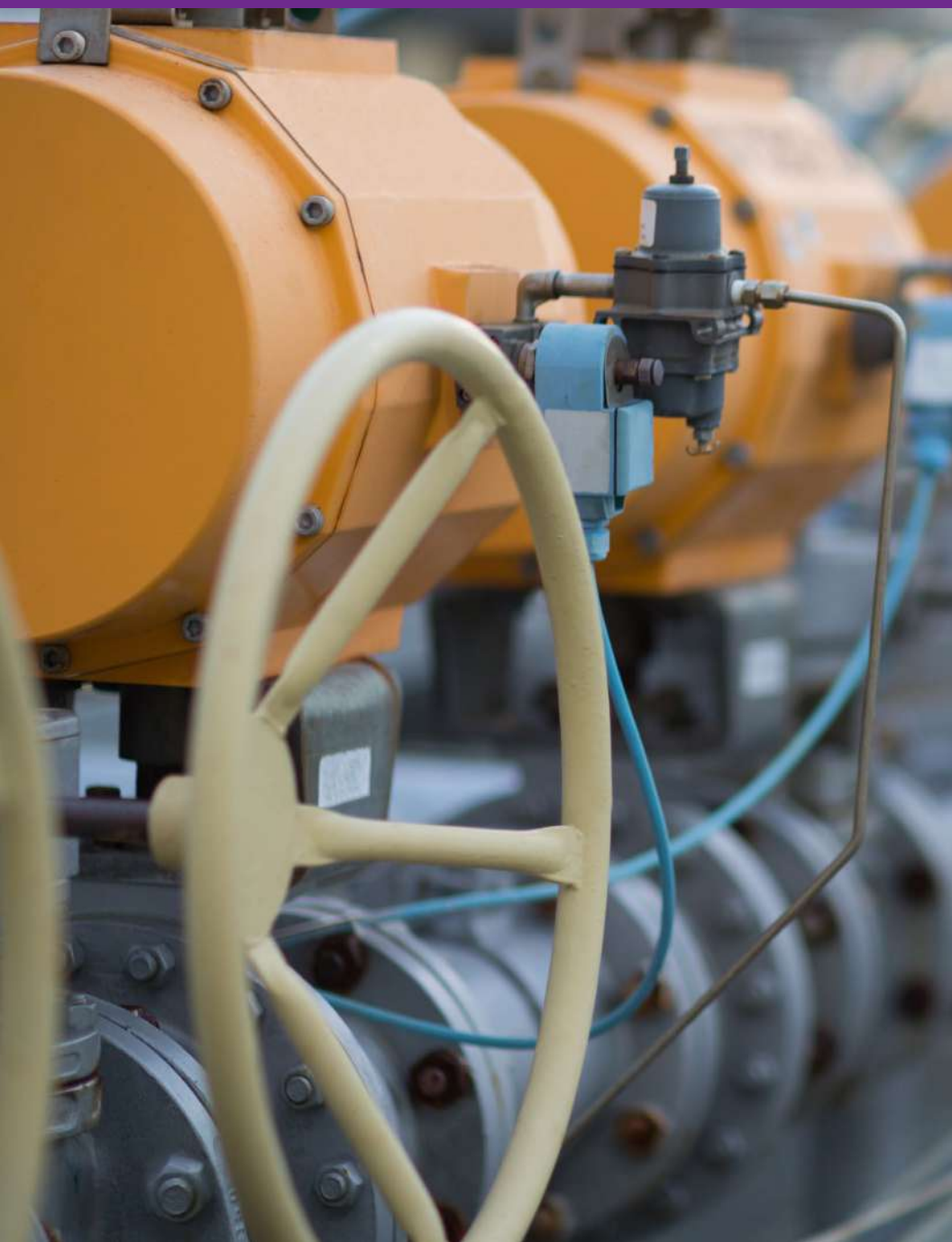

This chapter has been extracted from IPT's *Pipe Trades Handbook* by Robert A. Lee, with permission.

## 10.1 Basic Valve Types

There are numerous valve types, styles, sizes, and shapes available for use in industry. Even though there are dozens of valve varieties to choose from, the primary purpose of valves remains the same; that is to stop or start flow, or to regulate flow.

Regulation of flow includes: throttling, prevention of flow reversal, and relieving or regulating pressure within a system.

Selection of valves for a system is based on the valve's intended service and design function. There are eight basic valve designs available:

- Gate
- Globe
- Check
- Diaphragm
- Ball
- Butterfly
- Plug
- Relief

### 10.1.1 Gate Valves

Gate valves are used for on/off service and are designed to operate fully open or fully closed.

Because of excessive vibration and wear created in partially-closed gates, the valves are not intended for throttling or flow regulation. Gate valves are available in solid wedge, flexible wedge, split wedge, and double-disk styles. A typical gate valve and its major parts are shown in Figure 10.1.

See Tables 10.1 and 10.3 through 10.7 of this chapter for sizes and dimensions.

Wedge-type gate valves have a tapered

wedge that wedges between two tapered seats when the valve is closed. The solid-wedge design (Figure 10.2) is widely used and is suitable for air, gas, oil, steam, and water service. Flexible wedge gate valves are used in services that have a tendency to bind the solid-wedge design due to excessive variations in temperatures.

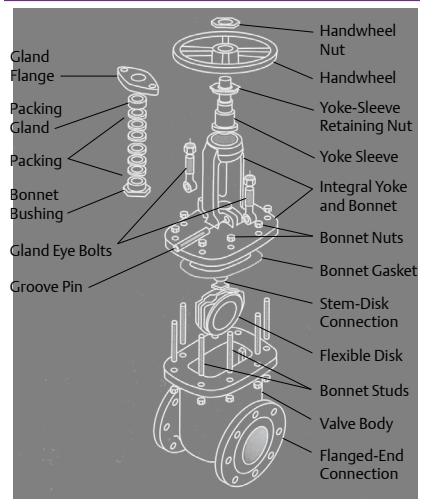

Figure 10.1 Gate Valve

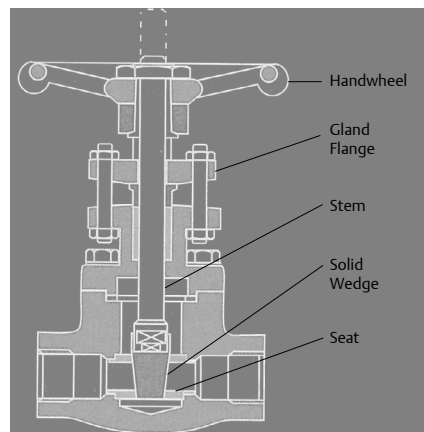

Figure 10.2 Solid-Wedge Gate Valve

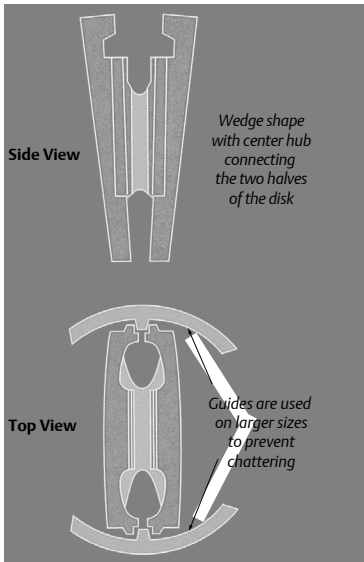

Figure 10.3 Flexible-Wedge Disk

The design of the flexible wedge (shown in Figure 10.3) provides good seating characteristics (opening and closing) for a wide range of temperatures while providing positive shutoff.

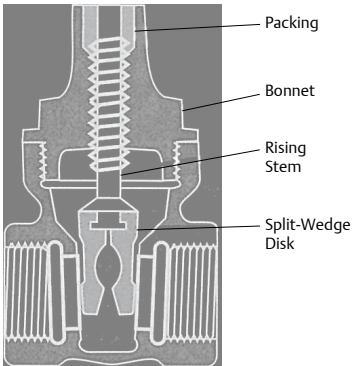

Figure 10.4 Split-Wedge Gate Valve

Split-wedge and double-disk gate valves have disks or wedges that are made of two pieces. In the split-wedge design (Figure 10.4), the last turn of the handwheel forces the two disks against the tapered seats. The double-

disk gate valve has parallel disks and seats. Closure of the double disk is accomplished by a spreader or wedge which forces the parallel disks against the seats. The double-disk gate valve is shown in Figure 10.5.

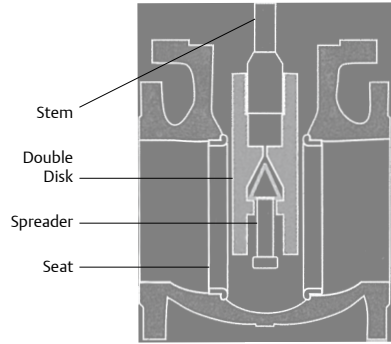

Figure 10.5 Double-Disk Gate Valve

Friction, which causes wear on seats and disks, is kept to a minimum in both the split-wedge and double-disk gate valves because the seat and disk are in contact only on closing the valve.

When installing either the split-wedge or double-disk gate valve, the stem of the valve must be vertical (valve upright) which ensures the disks do not jam apart before closing.

### 10.1.2 Globe Valves

Globe valves, unlike gate valves, are used in applications requiring frequent operation and/or throttling of flow. The design of the globe valve (shown in Figure 10.6) keeps seat erosion to a minimum, while making it an easy valve to service. When flow begins in the globe valve design, the disk moves completely away from the seat, thus minimizing erosion and wire drawing.

See Figures 10.30 and 10.36 through 10.42 of this chapter for sizes and dimensions.

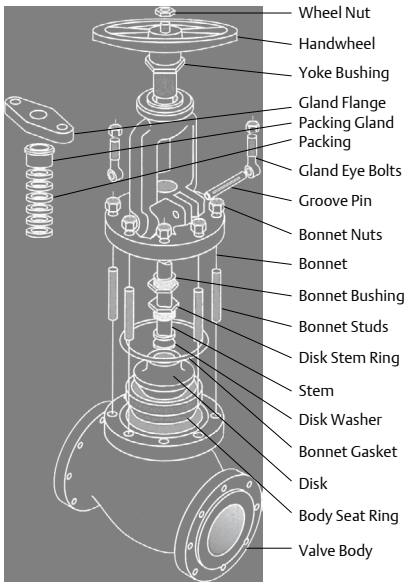

Figure 10.6 Globe Valve

Globe valves are available in three body styles: angle body, Y-pattern and T-pattern body, or straightway body (most common). All three body styles are suited for throttling, but each has its own flow characteristic and service applicability.

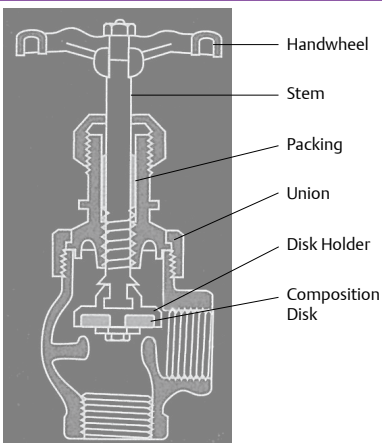

Figure 10.7 Angle Globe Valve (Composition Disk)

Angle body valves provide for a 90 degree change of direction (see Figure 10.7) which in some installations saves space, material, and installation time.

The inner design of the angle body valve offers less flow restriction than the conventional T-pattern, but more than the Y-pattern globe valve.

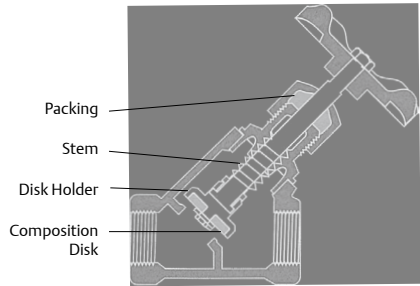

Figure 10.8 Y-Pattern Globe Valve (Composition Disk)

Y-pattern globe valves, because of the angle of the stem (45 or 60 degrees from the run), give very little flow restriction. Figure 10.8 shows a typical Y-pattern globe valve. The Y-pattern globe valve is ideally suited for applications requiring almost full flow in a valve, but with the characteristics of a globe valve.

Applications for the Y-pattern globe valve include boiler blow-offs and services where mud, grit, and/or viscous fluids may be encountered.

The main types of globe valves according to their seat arrangements are:

- Conventional-disk
- Plug-disk
- Composition-disk
- Needle valve

Conventional-disk globe valves use a short, tapered disk which fits into a matched tapered seat for closure and throttling (shown in Figure 10.9). When flow conditions have a tendency to deposit or coke on valve seats, the

conventional-disk valve design is often preferred. The narrow disk used in the conventional-disk valve will usually break through deposits, giving positive seating, rather than packing the deposits.

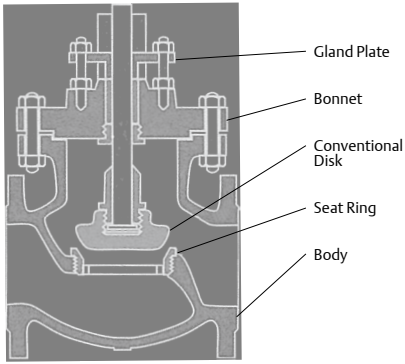

Figure 10.9 Conventional-Disk Globe Valve

The plug disk differs from the conventional disk in that the plug disk and seat arrangement are longer and more tapered. The longer area of the plug and seat give the plug valve maximum resistance to flow-induced erosion. An example of a plug-disk globe valve is shown in Figure 10.10.

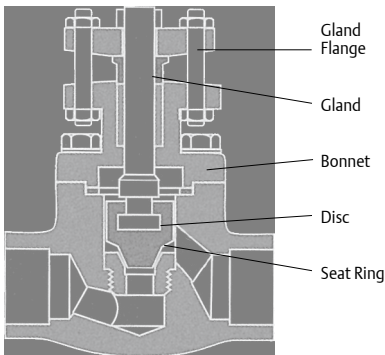

Figure 10.10 Plug-Disk Globe Valve

The composition-disk globe valve has a flat composition disk that fits flat against a seat rather than into a seat. This arrangement can be seen in Figure 10.11.

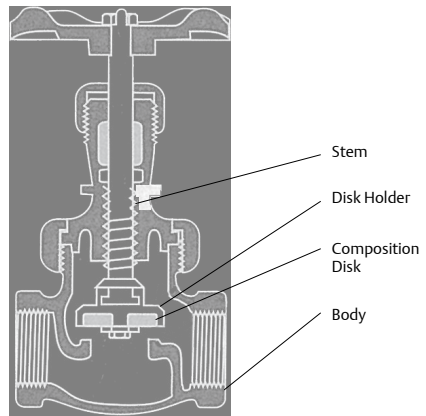

Figure 10.11 Composition-Disk Globe Valve

Various composition materials can be used in the disk holder depending on the intended service of the valve. By changing the composition disk material, the valve can be changed from one service to another. Because of the softer nature of certain compositions used in the disk, foreign matter usually embeds in the disk rather than causing leakage or scoring of the seat.

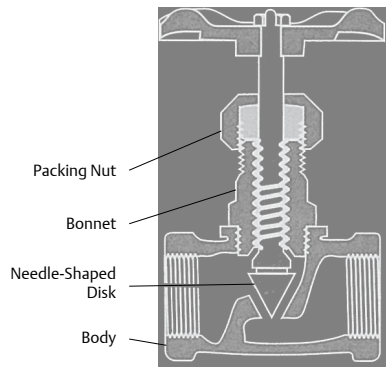

Figure 10.12 Needle Valve

The needle valve is another type of globe valve which is used for accurate throttling in high-pressure and/or high-temperature service.

Needle valves are designed for small

diameter lines requiring fine throttling of gases, steam, low-viscosity oil, water, or any other light liquid.

The valve consists of a sharp, pointed (needle-shaped) stem that controls flow through the seat. Figure 10.12 shows a typical needle valve.

### 10.1.3 Check Valves

Check valves are used to prevent flow reversal in piping systems and connected equipment. The two most common designs of check valves are:

- Swing check
- Lift check

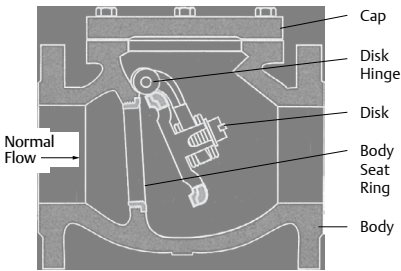

Figure 10.13 Swing Check Valve

The swing check valve design (shown in Figure 10.13) consists of a hinged disk that swings open when flow starts in the desired direction and swings closed in flow reversal situations. Because of this swinging action of the disk, it is important to install all swing check valves so that the disk closes positively by gravity. When fully open, the swing check offers less flow resistance than the lift check valve design.

In flow situations where shock closure and/or disk chatter are encountered, other varieties of swing check valves can be used to help minimize the problems. See Tables 10.8 through 10.14 of this chapter for sizes and dimensions

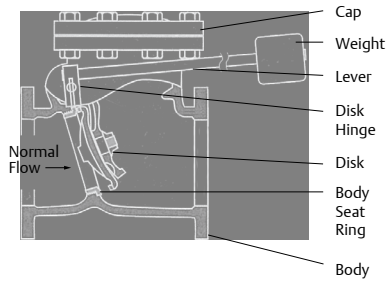

Figure 10.14 Lever and Weight Swing Check Valve

Swing check valves with outside lever and weight arrangements (shown in Figure 10.14) or spring-loaded disks can facilitate immediate closure in flow reverse. This immediate closure minimizes the possible damages of shock and disk chatter in systems. The tilting-disk swing check valve is another type of swing check valve that is used to help prevent slamming (see Figure 10.15)

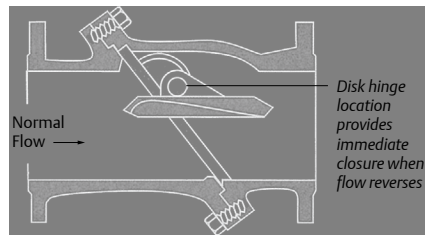

Figure 10.15 Tilting Check Valve

The lift check valve design (shown in Figure 10.16) is used in situations where pressure drop is not considered critical. The flow pattern through the valve corresponds to that of the globe valve. Lift check valves are available in horizontal and vertical designs.



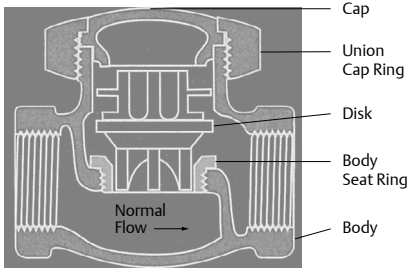

Figure 10.16 Horizontal-Lift Check Valve

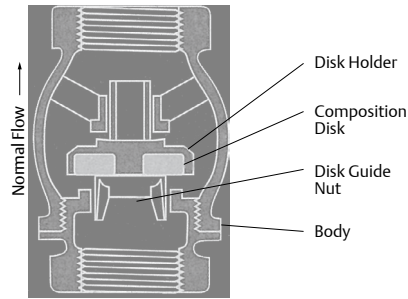

Figure 10.17 Vertical-Lift Check Valve

Vertical design check valves (shown in Figure 10.17) are for use in up-feed vertical lines only and will not work in the inverted or horizontal position. It is important when installing any lift check valve that the disk or ball lifts vertically when in operation.

### 10.1.4 Bypass Valves

In larger valve situations where high pressures and/or high temperatures are encountered, a smaller bypass valve is often installed to equalize pressure and/or to allow the pipe downstream to warm up before the larger valve is opened. Figure 10.18 shows a typical bypass arrangement, while Figure 10.19 gives standard bypass and auxiliary connection locations and sizes.

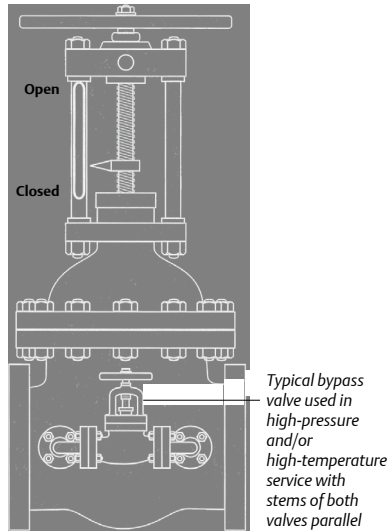

Figure 10.18 Bypass Valve

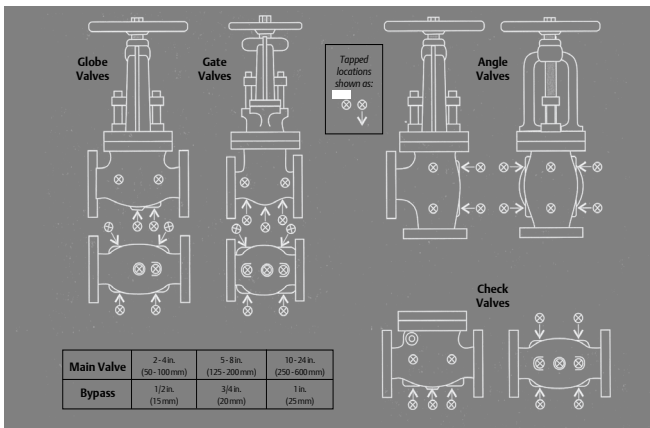

Figure 10.19 Bypass and Auxiliary Connections



### 10.1.5 Diaphragm Valves

Diaphragm valves (sometimes referred to as saunders valves) are designed to control flow in corrosive services where line content could adversely affect valve components. Other applications for diaphragm valves are in services where contamination from outside sources cannot be tolerated; for example, the pharmaceutical and food industries.

Diaphragm valves differ from other valves in that the body of the valve and line content is sealed off from all moving parts of the valve by a flexible diaphragm. This flexible diaphragm seal prevents stem packing leakage of line content and flow contamination by packing lubricants.

Even though there are many variations of diaphragm valve designs, most can be classified as either weir-type or straightway-type.

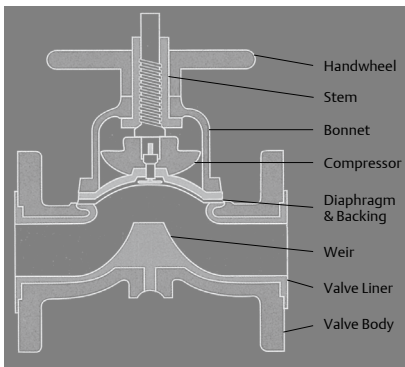

Figure 10.20 Weir-Type Diaphragm Valve

Weir-type diaphragm valves are the most common type of diaphragm valve used. Figure 10.20 shows a typical weir-type valve along with its major components.

The weir-type diaphragm valve incorporates a raised section (weir) halfway through the valve, which acts as a closure point for the flexible diaphragm. Because of the way the weir is formed in the body, diaphragm

movement is shortened, which in turn prolongs diaphragm life and reduces overall maintenance.

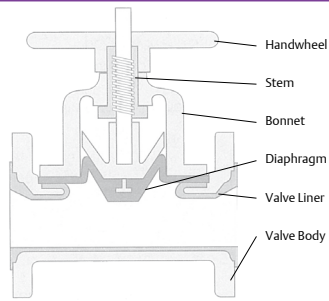

Figure 10.21 Straightway-Type Diaphragm Valve

Straightway-type diaphragm valves have no weir incorporated in the valve design. Figure 10.21 shows a typical straightway valve. This design gives the valve an uninterrupted passageway suited for flows which are viscous or contain solids.

There are many types of diaphragm materials available, depending on service and temperature conditions.

Because longer diaphragm movement is needed in the straightway-type valve compared to the weir-type, material selection is limited for the straightway-type valve.

### 10.1.6 Pinch Valves

The pinch valve, like the diaphragm valve, uses a flexible diaphragm in the closing and opening of the valve. Pinch valves use a flexible hollow sleeve which is pinched closed to stop flow by manual or power methods. A simple, air-operated pinch valve is shown in Figure 10.22.

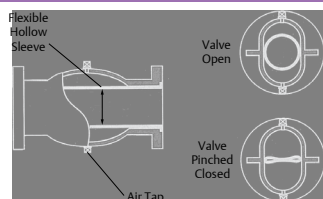

Figure 10.22 Air-Operated Pinch Valve

Pinch valves are ideally suited in services which carry suspended matter, slurries, and solid powder flows.

### 10.1.7 Ball Valves

The ball valve, as the name indicates, contains a ball-shaped plug within a valve body which regulates flow. The ball has a circular hole or flow-way through its center and when turned one-quarter of the way, the flow stops. Ball valves come in three general patterns:

- Venture-port
- Full-port
- Reduced-port (sometimes referred to as regular-port)

The port patterns indicate the inside diameter of the ball flow-way.

Ball valves may also be classified by their body style. Body styles come in one-piece and multi-piece bodies.

A typical reduced-port (or regular-port) ball valve with a multi-piece body is shown in Figure 10.23.

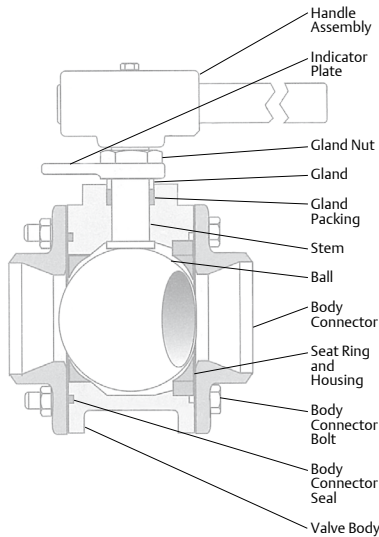

Figure 10.23 Reduced-Port Ball Valve

### 10.1.8 Butterfly Valves

The butterfly valve offers a simple design that is lightweight, compact, and inexpensive, particularly in larger valve sizes. It consists of a flat, circular disk hinged in its center, which closes or fully opens with a quarter turn. Seating for the disk is supplied by metal seats or resilient types of material like elastomers and plastics. Because of the advances in seating material, butterfly valves have found general acceptance in the oil, gas, chemical, water, and process fields. The valve is often used in place of a gate valve, but has the added advantage of flow regulation.

Butterfly valves are available in two basic body types:

- Wafer-type
- Double flanged-type

The wafer-type (shown in Figure 10.24) is mounted between two flanges and is held in place by flange bolts.

In situations where dismantling of equipment or lines may require disconnecting of one of the holding flanges, a lug-wafer butterfly valve (shown in Figure 10.25) has tapped lugs through which the flange bolts are screwed and hold the valve in place, even when one flange is removed. In most wafer butterfly valves, the elastomer seal also acts as its own flange gasket.

The double-flanged butterfly (shown in Figure 10.26) incorporates two flange ends which are bolted individually into the pipework or equipment flanges. Gaskets are used between the valve ends and connecting flanges.

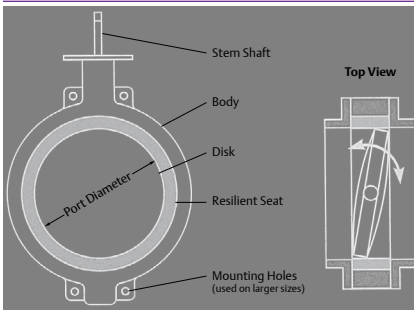

Figure 10.24 Wafer-Type Butterfly Valve

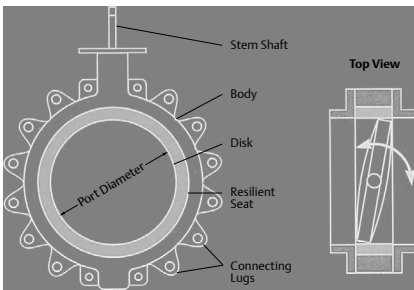

Figure 10.25 Lug-Butterfly Valve

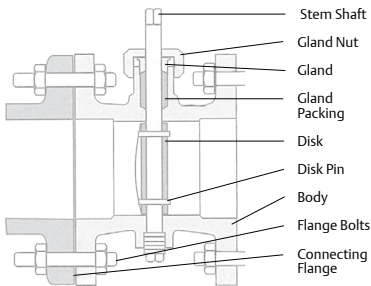

Figure 10.26 Double-Flanged Butterfly Valve

### 10.1.9 Plug Valves

Plug valves (also known as cock valves) consist of a tapered or parallel side plug which can be rotated a quarter turn within a valve body. The quarter turn gives full closure or fully open operation of the valve. There are two basic types of plug valves available:

- Lubricated plug
- Non-lubricated plug

One variation of the lubricated plug is shown in Figure 10.27.

The lubricated plug differs from the non-lubricated plug in that it provides a means to lubricate the seating surfaces of the valve. This lubrication helps to eliminate valve seizing while still providing a positive seal. Lubricated plugs should not be used if flow contamination may be a problem.

The plug valve design also lends itself to multi-port valve arrangements as shown in Figure 10.28.

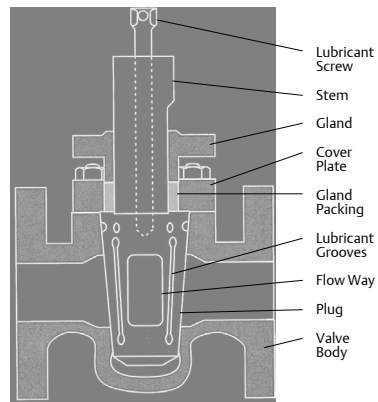

Figure 10.27 Lubricated Plug Valve

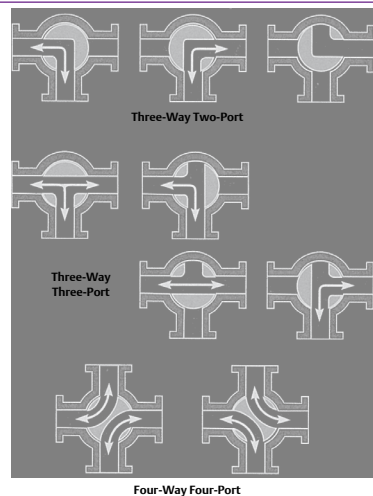

Figure 10.28 Multi-Port Plug Valve

Cast Iron Gate Valves / Dimensions Given in Inches and Millimeters (mm) <i>(taken from Face-to-Face of the Valve)</i>													
Cast Iron Gate Valves / ANSI Class 125, 250, 800													
Nominal Pipe Size		Flat Face / Class 125				Raised Face / Class 250				Raised Face / Class 800			
		Solid Wedge		Double Disk		Solid Wedge		Double Disk		Solid Wedge		Double Disk	
Inch	mm	Inch	mm	Inch	mm	Inch	mm	Inch	mm	Inch	mm	Inch	mm
1/4	8	---	---	---	---	---	---	---	---	---	---	---	---
3/8	10	---	---	---	---	---	---	---	---	---	---	---	---
1/2	15	---	---	---	---	---	---	---	---	---	---	---	---
3/4	20	---	---	---	---	---	---	---	---	---	---	---	---
1	25	---	---	---	---	---	---	---	---	---	---	---	---
1-1/4	32	---	---	---	---	---	---	---	---	---	---	---	---
1-1/2	40	---	---	---	---	---	---	---	---	---	---	---	---
2	50	7.00	177.8	7.00	177.8	8.50	215.9	8.50	215.9	11.50	292.1	11.50	292.1
2-1/2	65	7.50	190.5	7.50	190.5	9.50	241.3	9.50	241.3	13.00	330.2	13.00	330.2
3	80	8.00	203.2	8.00	203.2	11.12	282.5	11.12	282.5	14.00	355.6	14.00	355.6
4	100	9.00	228.6	9.00	228.6	12.00	304.8	12.00	304.8	17.00	431.8	17.00	431.8
5	125	10.00	254.0	10.00	254.0	15.00	381.0	15.00	381.0	---	---	---	---
6	150	10.50	266.7	10.50	266.7	15.88	403.4	15.88	403.4	22.00	558.8	22.00	558.8
8	200	11.50	292.1	11.50	292.1	16.50	419.1	16.50	419.1	26.00	660.4	26.00	660.4
10	250	13.00	330.2	13.00	330.2	18.00	457.2	18.00	457.2	31.00	787.4	31.00	787.4
12	300	14.00	355.6	14.00	355.6	19.75	501.7	19.75	501.7	33.00	838.2	33.00	838.2
14	350	15.00	381.0	---	---	22.50	571.5	22.50	571.5	---	---	---	---
16	400	16.00	406.4	---	---	24.00	609.6	24.00	609.6	---	---	---	---
18	450	17.00	431.8	---	---	26.00	660.4	26.00	660.4	---	---	---	---
20	500	18.00	457.2	---	---	28.00	711.2	28.00	711.2	---	---	---	---
22	550	---	---	---	---	---	---	---	---	---	---	---	---
24	600	20.00	508.0	---	---	31.00	787.4	31.00	787.4	---	---	---	---
26	650	---	---	---	---	---	---	---	---	---	---	---	---
28	700	---	---	---	---	---	---	---	---	---	---	---	---
30	750	---	---	---	---	---	---	---	---	---	---	---	---
32	800	---	---	---	---	---	---	---	---	---	---	---	---
34	850	---	---	---	---	---	---	---	---	---	---	---	---
36	900	---	---	---	---	---	---	---	---	---	---	---	---

**Notes**

1. (---) Indicates valve size is not shown in ASME/ANSI standards but may be commercially available.
2. Millimeter dimensions are rounded off to first decimal point.
3. Dimensions based on ASME/ANSI B16.10 Standard.

Figure 10.29 Cast Iron Gate Valves

<b>Cast Iron Globe Valves / Dimensions Given in Inches and Millimeters (mm)</b> (taken from Face-to-Face for Straightway Valves; Center-to-Face for Angle Valves)													
<b>Cast Iron Globe Valves / ANSI Class 125 &amp; 250</b>													
Nominal Pipe Size		Flat Face / Class 125						Raised Face / Class 250					
		Straightway		Angle Globe		Control Style		Straightway		Angle Globe		Control Style	
Inch	mm	Inch	mm	Inch	mm	Inch	mm	Inch	mm	Inch	mm	Inch	mm
1/4	8	---	---	---	---	---	---	---	---	---	---	---	---
3/8	10	---	---	---	---	---	---	---	---	---	---	---	---
1/2	15	---	---	---	---	---	---	---	---	---	---	7.50	190.5
3/4	20	---	---	---	---	---	---	---	---	---	---	7.62	193.5
1	25	---	---	---	---	7.25	190.5	---	---	---	---	7.55	196.9
1-1/4	32	---	---	---	---	---	---	---	---	---	---	---	---
1-1/2	40	---	---	---	---	8.75	222.3	---	---	---	---	9.25	235.0
2	50	8.00	203.2	4.00	101.6	10.00	254.0	10.50	266.7	5.25	133.4	10.50	266.7
2-1/2	65	8.50	215.9	4.25	107.0	10.88	276.4	11.50	292.1	5.75	146.1	11.50	292.1
3	80	9.50	241.3	4.75	120.7	11.75	298.5	12.50	317.5	6.25	158.8	12.50	317.5
4	100	11.50	292.1	5.75	146.1	13.88	352.6	14.00	355.6	7.00	177.8	14.50	368.3
5	125	13.00	330.2	6.50	165.1	---	---	15.75	400.1	7.88	200.2	---	---
6	150	14.00	355.6	7.00	177.8	17.75	450.9	17.50	444.5	8.75	222.3	18.62	473.0
8	200	19.50	495.3	9.75	247.7	21.38	543.1	21.00	533.4	10.50	266.7	22.38	568.5
10	250	24.50	622.3	12.25	311.1	26.50	673.1	24.50	622.3	12.25	311.2	27.88	708.2
12	300	27.50	698.5	13.75	349.3	29.00	736.6	28.00	711.2	14.00	355.6	30.50	774.7
14	350	31.00	787.4	15.50	393.7	35.00	889.0	---	---	---	---	36.50	927.1
16	400	36.00	914.4	18.00	457.2	40.00	1016.0	---	---	---	---	41.62	1057.2
18	450	---	---	---	---	---	---	---	---	---	---	---	---
20	500	---	---	---	---	---	---	---	---	---	---	---	---
22	550	---	---	---	---	---	---	---	---	---	---	---	---
24	600	---	---	---	---	---	---	---	---	---	---	---	---
26	650	---	---	---	---	---	---	---	---	---	---	---	---
28	700	---	---	---	---	---	---	---	---	---	---	---	---
30	750	---	---	---	---	---	---	---	---	---	---	---	---
32	800	---	---	---	---	---	---	---	---	---	---	---	---
36	900	---	---	---	---	---	---	---	---	---	---	---	---

**Notes**

- (---) Indicates valve size is not shown in ASME/ANSI standards but may be commercially available.
- Millimeter dimensions are rounded off to first decimal point.
- Dimensions based on ASME/ANSI B16.10 Standard.
- Dimensions for standard straightway lift and swing check valves are interchangeable with straightway globe valve dimensions (excluding 16" (400mm) vertical swing checks).
- Dimensions for standard angle lift check valves are interchangeable with angle globe valve dimensions.

Figure 10.30 Cast Iron Globe Valves

Steel Gate Valves / Dimensions Given in Inches and Millimeters (mm) <i>(taken from Face-to-Face and End-to-End of Valves)</i>									
Steel Gate Valves / ANSI Class 150									
Nominal Pipe Size		Raised Face / Class 150				Beveled End / Class 150			
		Solid Wedge		Double Disk		Solid Wedge		Double Disk	
Inch	mm	Inch	mm	Inch	mm	Inch	mm	Inch	mm
1/4	8	4.00	101.6	4.00	101.6	4.00	101.6	4.00	101.6
3/8	10	4.00	101.6	4.00	101.6	4.00	101.6	4.00	101.6
1/2	15	4.25	108.0	4.25	108.0	4.25	108.0	4.25	108.0
3/4	20	4.62	117.4	4.62	117.4	4.62	117.4	4.62	117.4
1	25	5.00	127.0	5.00	127.0	5.00	127.0	5.00	127.0
1-1/4	32	5.50	139.7	5.50	139.7	5.50	139.7	5.50	139.7
1-1/2	40	6.50	165.1	6.50	165.1	6.50	165.1	6.50	165.1
2	50	7.00	177.8	7.00	177.8	8.50	215.9	8.50	215.9
2-1/2	65	7.50	190.5	7.50	190.5	9.50	241.3	9.50	241.3
3	80	8.00	203.2	8.00	203.2	11.12	282.5	11.12	282.5
4	100	9.00	228.6	9.00	228.6	12.00	304.8	12.00	304.8
5	125	10.00	254.0	10.00	254.0	15.00	381.0	15.00	381.0
6	150	10.50	266.7	10.50	266.7	15.88	403.4	15.88	403.4
8	200	11.50	292.1	11.50	292.1	16.50	419.1	16.50	419.1
10	250	13.00	330.2	13.00	330.2	18.00	457.2	18.00	457.2
12	300	14.00	355.6	14.00	355.6	19.75	501.7	19.75	501.7
14	350	15.00	381.0	15.00	381.0	22.50	571.5	22.50	571.5
16	400	16.00	406.4	16.00	406.4	24.00	609.6	24.00	609.6
18	450	17.00	431.8	17.00	431.8	26.00	660.4	26.00	660.4
20	500	18.00	457.2	18.00	457.2	28.00	711.2	28.00	711.2
22	550	---	---	---	---	30.00	762.0	30.00	762.0
24	600	20.00	508.0	20.00	508.0	32.00	812.8	32.00	812.8
26	650	22.00	558.8	22.00	558.8	---	---	34.00	863.6
28	700	24.00	609.6	24.00	609.6	---	---	36.00	914.4
30	750	24.00	609.6	24.00	609.6	---	---	36.00	914.4
32	800	---	---	---	---	---	---	38.00	965.2
34	850	---	---	---	---	---	---	40.00	1016
36	900	28.00	711.2	28.00	711.2	---	---	40.00	1016

Figure 10.31 Steel Gate Valve (Class 150)

<b>Steel Gate Valves / Dimensions Given in Inches and Millimeters (mm)</b> <i>(taken from Face-to-Face and End-to-End of Valves)</i>									
<b>Steel Gate Valves / ANSI Class 300</b>									
Nominal Pipe Size		Raised Face / Class 300				Beveled End / Class 300			
		Solid Wedge		Double Disk		Solid Wedge		Double Disk	
Inch	mm	Inch	mm	Inch	mm	Inch	mm	Inch	mm
1/4	8	---	---	---	---	---	---	---	---
3/8	10	---	---	---	---	---	---	---	---
1/2	15	5.50	139.7	---	---	5.50	139.7	---	---
3/4	20	6.00	152.4	---	---	6.00	152.4	---	---
1	25	6.50	165.1	---	---	6.50	165.1	---	---
1-1/4	32	7.00	177.8	---	---	7.00	177.8	---	---
1-1/2	40	7.50	190.5	7.50	190.5	7.50	190.5	7.50	190.5
2	50	8.50	215.9	8.50	215.9	8.50	215.9	8.50	215.9
2-1/2	65	9.50	241.3	9.50	241.3	9.50	241.3	9.50	241.3
3	80	11.12	282.5	11.12	282.5	11.12	282.5	11.12	282.5
4	100	12.00	304.8	12.00	304.8	12.00	304.8	12.00	304.8
5	125	15.00	381.0	15.00	381.0	15.00	381.0	15.00	381.0
6	150	15.88	403.4	15.88	403.4	15.88	403.4	15.88	403.4
8	200	16.50	419.1	16.50	419.1	16.50	419.1	16.50	419.1
10	250	18.00	457.2	18.00	457.2	18.00	457.2	18.00	457.2
12	300	19.75	501.7	19.75	501.7	19.75	501.7	19.75	501.7
14	350	30.00	762.0	30.00	762.0	30.00	762.0	30.00	762.0
16	400	33.00	838.2	33.00	838.2	33.00	838.2	33.00	838.2
18	450	36.00	914.4	36.00	914.4	36.00	914.4	36.00	914.4
20	500	39.00	990.6	39.00	990.6	39.00	990.6	39.00	990.6
22	550	43.00	1092.2	43.00	1092.2	43.00	1092.2	43.00	1092.2
24	600	45.00	1143.0	45.00	1143.0	45.00	1143.0	45.00	1143.0
26	650	49.00	1244.6	49.00	1244.6	49.00	1244.6	49.00	1244.6
28	700	53.00	1346.2	53.00	1346.2	53.00	1346.2	53.00	1346.2
30	750	55.00	1397.0	55.00	1397.0	55.00	1397.0	55.00	1397.0
32	800	60.00	1524.0	60.00	1524.0	60.00	1524.0	60.00	1524.0
34	850	64.00	1625.6	64.00	1625.6	64.00	1625.6	64.00	1625.6
36	900	68.00	1727.2	68.00	1727.2	68.00	1727.2	68.00	1727.2

Figure 10.32 Steel Gate Valve (Class 300)

Steel Gate Valves / Dimensions Given in Inches and Millimeters (mm) <i>(taken from Face-to-Face and End-to-End of Valves)</i>															
Steel Gate Valves / ANSI Class 400 & 600															
Nominal Pipe Size		Raised Face & Beveled End / Class 400				Raised Face / Class 600				Beveled End / Class 600					
		Solid Wedge		Double Disk		Solid Wedge		Double Disk		Solid Wedge		Double Disk		Short Pattern	
in	mm	in	mm	in	mm	in	mm	in	mm	in	mm	in	mm	in	mm
1/2	15	6.5	165.1	---	---	6.5	165.1	---	---	6.50	165.1	---	---	---	---
3/4	20	7.5	190.5	---	---	7.5	190.5	---	---	7.5	190.5	---	---	---	---
1	25	8.5	215.9	8.5	215.9	8.5	215.9	8.5	215.9	8.5	215.9	8.5	215.9	5.25	133.4
1-1/4	32	9.0	228.6	9.0	228.6	9.0	228.6	9.0	228.6	9.0	228.6	9.0	228.6	5.75	146.1
1-1/2	40	9.5	241.3	9.5	241.3	9.5	241.3	9.5	241.3	9.5	241.3	9.5	241.3	6.0	152.4
2	50	11.5	292.1	11.5	292.1	11.5	292.1	11.5	292.1	11.5	292.1	11.5	292.1	7.0	177.8
2-1/2	65	13.0	330.2	13.0	330.2	13.0	330.2	13.0	330.2	13.0	330.2	13.0	330.2	8.5	215.9
3	80	14.0	355.6	14.0	355.6	14.0	355.6	14.0	355.6	14.0	355.6	14.0	355.6	10.0	254.0
4	100	16.0	406.4	16.0	406.4	17.0	431.8	17.0	431.8	17.0	431.8	17.0	431.8	12.0	304.8
5	125	18.0	457.2	18.0	457.2	20.0	508.0	20.0	508.0	20.0	508.0	20.0	508.0	15.0	381.0
6	150	19.5	495.3	19.5	495.3	22.0	558.8	22.0	558.8	22.0	558.8	22.0	558.8	18.0	457.2
8	200	23.5	596.9	23.5	596.9	26.0	660.4	26.0	660.4	26.0	660.4	26.0	660.4	23.0	584.2
10	250	26.5	673.1	26.5	673.1	31.0	787.4	31.0	787.4	31.0	787.4	31.0	787.4	28.0	711.2
12	300	30.0	762.0	30.0	762.0	33.0	838.2	33.0	838.2	33.0	838.2	33.0	838.2	32.0	812.8
14	350	32.5	825.5	32.5	825.5	35.0	889.0	35.0	889.0	35.0	889.0	35.0	889.0	35.0	889.0
16	400	35.5	901.7	35.5	901.7	39.0	990.6	39.0	990.6	39.0	990.6	39.0	990.6	39.0	990.6
18	450	38.5	977.9	38.5	977.9	43.0	1092.2	43.0	1092.2	43.0	1092.2	43.0	1092.2	43.0	1092.2
20	500	41.5	1054.1	41.5	1054.1	47.0	1193.8	47.0	1193.8	47.0	1193.8	47.0	1193.8	47.0	1193.8
22	550	45.0	1143.0	45.0	1143.0	51.0	1295.4	51.0	1295.4	51.0	1295.4	51.0	1295.4	---	---
24	600	48.5	1231.9	48.5	1231.9	55.0	1397.0	55.0	1397.0	55.0	1397.0	55.0	1397.0	55.0	1397.0
26	650	---	---	---	1308.1	57.0	1447.8	57.0	1447.8	57.0	1447.8	57.0	1447.8	---	---
28	700	---	---	---	1397.0	61.0	1549.4	61.0	1549.4	61.0	1549.4	61.0	1549.4	---	---
30	750	---	---	---	1524.0	65.0	---	65.0	1651.0	65.0	1651.0	65.0	1651.0	---	---
32	800	---	---	---	1651.0	---	---	70.0	1778.0	---	---	70.0	1778.0	---	---
34	850	---	---	---	1778.0	---	---	76.0	1930.4	---	---	76.0	1930.4	---	---
36	900	---	---	---	1879.6	---	---	82.0	2082.8	---	---	82.0	2082.8	---	---

Figure 10.33 Steel Gate Valve (Class 400 and 600)



Steel Gate Valves / Dimensions Given in Inches and Millimeters (mm) (taken from Face-to-Face and End-to-End of Valves)													
Steel Gate Valves / ANSI CLASS 900 & 1500													
Nominal Pipe Size		Raised Face & Beveled End / Class 900				Beveled End / Class 900		Raised Face & Beveled End / Class 1500					
		Solid Wedge		Double Disk		Short Pattern		Solid Wedge		Double Disk		Short Pattern	
Inch	mm	Inch	mm	Inch	mm	Inch	mm	Inch	mm	Inch	mm	Inch	mm
3/4	20	---	---	---	---	---	---	---	---	---	---	---	---
1	25	10.00	254.0	---	---	5.50	139.7	10.00	254.0	---	---	5.50	139.7
1-1/4	32	11.00	279.4	---	---	6.50	165.1	11.00	279.4	---	---	6.50	165.1
1-1/2	40	12.00	304.8	---	---	7.00	177.8	12.00	304.8	---	---	7.00	177.8
2	50	14.50	368.3	14.50	368.3	8.50	215.9	14.50	368.3	14.50	368.3	8.50	215.9
2-1/2	65	16.50	419.1	16.50	419.1	10.00	254.0	16.50	419.1	16.50	419.1	10.00	254.0
3	80	15.00	381.0	15.00	381.0	12.00	304.8	18.50	469.9	18.50	469.9	12.00	304.8
4	100	18.00	457.2	18.00	457.2	14.00	355.6	21.50	546.1	21.50	546.1	16.00	406.4
5	125	22.00	558.8	22.00	558.8	17.00	431.8	26.50	673.1	26.50	673.1	19.00	482.6
6	150	24.00	609.6	24.00	609.6	20.00	508.0	27.75	704.9	27.75	704.9	22.00	558.8
8	200	29.00	736.6	29.00	736.6	26.00	660.4	32.75	831.9	32.75	831.9	28.00	711.2
10	250	33.00	838.2	33.00	838.2	31.00	787.4	39.00	990.6	39.00	990.6	34.00	863.6
12	300	38.00	965.2	38.00	965.2	36.00	914.4	44.50	1130.3	44.50	1130.3	39.00	990.6
14	350	40.50	1028.7	40.50	1028.7	39.00	990.6	49.50	1257.3	49.50	1257.3	42.00	1066.8
16	400	44.50	1130.3	44.50	1130.3	43.00	1092.2	54.50	1384.3	54.50	1384.3	47.00	1193.8
18	450	48.00	1219.2	48.00	1219.2	---	---	60.50	1536.7	60.50	1536.7	53.00	1346.2
20	500	52.00	1320.8	52.00	1320.8	---	---	65.50	1663.7	65.50	1663.7	58.00	1473.2
22	550	---	---	---	---	---	---	---	---	---	---	---	---
24	600	61.00	1549.4	61.00	1549.4	---	---	76.50	1943.1	76.50	1943.1	---	---

Figure 10.34 Steel Gate Valve (Class 900 and 1500)

<b>Steel Gate Valves / Dimensions Given in Inches and Millimeters (mm)</b> <i>(taken from Face-to-Face and End-to-End of Valves)</i>											
<b>STEEL GATE VALVES / ANSI CLASS 2500</b>											
<b>Nominal Pipe Size</b>		<b>Raised Face / Class 2500</b>				<b>Beveled End / Class 2500</b>					
		<b>Solid Wedge</b>		<b>Double Disk</b>		<b>Solid Wedge</b>		<b>Double Disk</b>		<b>Short Pattern</b>	
<b>in</b>	<b>mm</b>	<b>in</b>	<b>mm</b>	<b>in</b>	<b>mm</b>	<b>in</b>	<b>mm</b>	<b>in</b>	<b>mm</b>	<b>in</b>	<b>mm</b>
1/2	15	10.38	263.7	---	---	10.38	263.7	---	---	---	---
3/4	20	10.75	273.1	---	---	10.75	273.1	---	---	---	---
1	25	12.12	307.9	---	---	12.12	307.9	---	---	7.31	185.7
1-¼	32	13.75	349.3	---	---	13.75	349.3	---	---	9.12	231.7
1-½	40	15.12	384.1	---	---	15.12	384.1	---	---	9.12	231.7
2	50	17.75	450.9	17.75	450.9	17.75	450.9	17.75	450.9	11.00	279.4
2-½	65	20.00	508.0	20.00	508.0	20.00	508.0	20.00	508.0	13.00	330.2
3	80	22.75	577.9	22.75	577.9	22.75	577.9	22.75	557.9	14.50	368.3
4	100	26.50	673.1	26.50	673.1	26.50	673.1	26.50	673.1	18.00	457.2
5	125	31.25	793.8	31.25	793.8	31.25	793.8	31.25	793.8	21.00	533.4
6	150	36.00	914.4	36.00	914.4	36.00	914.4	36.00	914.4	24.00	609.6
8	200	40.25	1022.4	40.25	1022.4	40.25	1022.4	40.25	1022.4	30.00	762.0
10	250	50.00	1270.0	50.00	1270.0	50.00	1270.0	50.00	1270.0	36.00	914.4
12	300	56.00	1422.4	56.00	1422.4	56.00	1422.4	56.00	1422.4	41.00	1041.4
14	350	---	---	---	---	---	---	---	---	44.00	1117.6
16	400	---	---	---	---	---	---	---	---	49.00	1244.6
18	450	---	---	---	---	---	---	---	---	55.00	1397.0

**Notes**

- (---) Indicates valve size is not shown in ASME/ANSI standards but may be commercially available.
- Millimeter dimensions are rounded off to first decimal point.
- Dimensions based on ASME/ANSI B16.10 Standard.
- Short pattern dimensions apply to pressure seal or flange less bonnet valves (option on bolted bonnets).

Figure 10.35. Steel Gate Valve (Class 2500)

<b>Steel Globe and Check Valves / Dimensions Given in Inches and Millimeters (mm)</b> <i>(taken from Face-to-Face and End-to-End for Straightway Valves; Center-to-Face and Center-to-End for Angle Valves)</i>											
<b>Steel Globe and Check Valves / ANSI Class 150</b>											
<b>Nominal Pipe Size</b>		<b>Raised Face and Beveled End / Class 150</b>									
		<b>Straightway Globe</b>		<b>Angle Globe</b>		<b>Y-Pattern Globe</b>		<b>Control Valve Globe (°)</b>		<b>Swing Check</b>	
<b>in</b>	<b>mm</b>	<b>in</b>	<b>mm</b>	<b>in</b>	<b>mm</b>	<b>in</b>	<b>mm</b>	<b>in</b>	<b>mm</b>	<b>in</b>	<b>mm</b>
1/4	8	4.00	101.6	2.00	50.8	---	---	---	---	4.00	101.6
3/8	10	4.00	101.6	2.00	50.8	---	---	---	---	4.00	101.6
1/2	15	4.25	108.0	2.25	57.2	5.50	139.7	---	---	4.25	108.0
3/4	20	4.62	117.4	2.50	63.5	6.00	152.4	---	---	4.62	117.4
1	25	5.00	127.0	2.75	69.9	6.50	165.1	7.25	184.2	5.00	127.0
1-¼	32	5.50	139.7	3.00	76.2	7.25	184.2	---	---	5.50	139.7
1-½	40	6.50	165.1	3.25	82.6	8.00	203.2	8.75	222.3	6.50	165.1
2	50	8.00	203.2	4.00	101.6	9.00	228.6	10.00	254.0	8.00	203.2
2-½	65	8.50	215.9	4.25	108.0	11.00	279.4	10.88	276.4	8.50	215.9
3	80	9.50	241.3	4.75	120.7	12.50	317.5	11.75	298.5	9.50	241.3
4	100	11.50	292.1	5.75	146.1	14.50	368.3	13.88	352.6	11.50	292.1
5	125	14.00	355.6	7.00	177.8	---	---	---	---	13.00	355.6
6	150	16.00	406.4	8.00	203.2	18.50	469.9	17.75	450.9	14.00	406.4
8	200	19.50	495.3	9.75	247.7	23.50	596.9	21.38	543.1	19.50	495.3
10	250	24.50	622.3	12.25	311.2	26.50	673.1	26.50	673.1	24.50	622.3
12	300	27.50	698.5	13.75	349.3	30.50	774.7	29.00	736.6	27.50	698.5
14	350	31.00	787.4	15.50	393.7	---	---	35.00	889.0	31.50	787.4
16	400	36.00	914.4	18.00	457.2	---	---	40.00	1016.0	34.00	914.4
18	450	---	---	---	---	---	---	---	---	38.50	977.9
20	500	---	---	---	---	---	---	---	---	38.50	977.9
22	550	---	---	---	---	---	---	---	---	42.00	1066.8
24	600	---	---	---	---	---	---	---	---	51.00	1295.4
26	650	---	---	---	---	---	---	---	---	51.00	1295.4
28	700	---	---	---	---	---	---	---	---	57.00	1447.8
30	750	---	---	---	---	---	---	---	---	60.00	1524.0
32	800	---	---	---	---	---	---	---	---	---	---
34	850	---	---	---	---	---	---	---	---	---	---
36	900	---	---	---	---	---	---	---	---	77.00	1955.8

Note: Control valve dimensions pertain to raised-face flange valves only.

Figure 10.36 Steel Globe / Check Valve (Class 150)

Steel Globe and Check Valves / Dimensions Given in Inches and Millimeters (mm) <i>(taken from Face-to-Face and End-to-End for Straightway Valves; Center-to-Face and Center-to-End for Angle Valves)</i>									
Steel Globe and Check Valves / ANSI Class 300									
Nominal Pipe Size		Raised Face and Beveled End / Class 300							
		Straightway Globe		Angle Globe		Control Valve Globe (*)		Swing Check	
in	mm	in	mm	in	mm	in	mm	in	mm
1/4	8	---	---	---	---	---	---	---	---
3/8	10	---	---	---	---	---	---	---	---
1/2	15	6.00	152.4	3.00	76.2	7.50	190.5	---	---
3/4	20	7.00	177.8	3.50	88.9	7.62	193.6	---	---
1	25	8.00	203.2	4.00	101.6	7.75	196.9	8.50	215.9
1-1/4	32	8.50	215.9	4.25	108.0	---	---	9.00	228.6
1-1/2	40	9.00	228.6	4.50	114.3	9.25	235.0	9.50	241.3
2	50	10.50	266.7	5.25	133.4	10.50	266.7	10.50	266.7
2-1/2	65	11.50	292.1	5.75	146.1	11.50	292.1	11.50	292.1
3	80	12.50	317.5	6.25	158.8	12.50	321.3	12.50	317.5
4	100	14.00	355.6	7.00	177.8	14.50	368.3	14.00	355.6
5	125	15.75	400.1	7.88	200.2	---	---	15.75	400.1
6	150	17.50	444.5	8.75	222.3	18.62	473.0	17.50	444.5
8	200	22.00	558.8	11.00	279.4	22.38	568.5	21.00	533.4
10	250	24.50	622.3	12.25	311.2	27.88	708.2	24.50	622.3
12	300	28.00	711.2	14.00	355.6	30.50	774.7	28.00	711.2
14	350	---	---	---	---	36.50	927.1	33.00	838.2
16	400	---	---	---	---	41.62	1057.2	34.00	863.6
18	450	---	---	---	---	---	---	38.50	977.9
20	500	---	---	---	---	---	---	40.00	1016.0
22	550	---	---	---	---	---	---	44.00	1117.6
24	600	---	---	---	---	---	---	53.00	1346.2
26	650	---	---	---	---	---	---	53.00	1346.2
28	700	---	---	---	---	---	---	59.00	1498.6
30	750	---	---	---	---	---	---	62.75	1593.9
32	800	---	---	---	---	---	---	---	---
34	850	---	---	---	---	---	---	---	---
36	900	---	---	---	---	---	---	82.00	2082.8

*Control valve dimensions pertain to raised face flange valves only.*

Figure 10.37 Steel Globe / Check Valve (Class 300)

<b>Steel Globe and Check Valves / Dimensions Given in Inches and Millimeters (mm)</b> <i>(taken from Face-to-Face and End-to-End for Straightway Valves and Center-to-Face and Center-to-End for Angle Valves)</i>													
								Long Pattern					
Nominal Pipe Size		Raised Face and Beveled End / Class 400						Raised Face & Beveled End / Class 600					
		Straightway Globe		Angle Globe		Swing Check		Straightway Globe		Angle Globe		Swing Check	
in	mm	in	mm	in	mm	in	mm	in	mm	in	mm	in	mm
1/2	15	6.50	165.1	3.25	82.6	6.50	165.1	6.50	165.1	3.25	82.6	6.50	165.1
3/4	20	7.50	190.5	3.75	95.3	7.50	190.5	7.50	190.5	3.75	95.3	7.50	190.5
1	25	8.50	215.9	4.25	108.0	8.50	215.9	8.50	215.9	4.25	108.0	8.50	215.9
1-¼	32	9.00	228.6	4.50	114.3	9.00	228.6	9.00	228.6	4.50	114.3	9.00	228.6
1-½	40	9.50	241.3	4.75	120.7	9.50	241.3	9.50	241.3	4.75	120.7	9.50	241.3
2	50	11.50	292.1	5.75	146.1	11.50	292.1	11.50	292.1	5.75	146.1	11.50	292.1
2-½	65	13.00	330.2	6.50	165.1	13.00	330.2	13.00	330.2	6.50	165.1	13.00	330.2
3	80	14.00	355.6	7.00	177.8	14.00	355.6	14.00	355.6	7.00	177.8	14.00	355.6
4	100	16.00	406.4	8.00	203.2	16.00	406.4	17.00	431.8	8.50	215.9	17.00	431.8
5	125	18.00	457.2	9.00	228.6	18.00	457.2	20.00	508.0	10.00	254.0	20.00	508.0
6	150	19.50	495.3	9.75	247.7	19.50	495.3	22.00	558.8	11.00	279.4	22.00	558.8
8	200	23.50	596.9	11.75	298.5	23.50	596.9	26.00	660.4	13.00	330.2	26.00	660.4
10	250	26.50	673.1	13.25	336.6	26.50	673.1	31.00	787.4	15.50	393.7	31.00	787.4
12	300	30.00	762.0	15.00	381.0	30.00	762.0	33.00	838.2	16.50	419.1	33.00	838.2
14	350	---	---	---	---	35.00	889.0	---	---	---	---	35.00	889.0
16	400	---	---	---	---	35.50	901.7	---	---	---	---	39.00	990.6
18	450	---	---	---	---	40.00	1016.0	---	---	---	---	43.00	1092.2
20	500	---	---	---	---	41.50	1054.1	---	---	---	---	47.00	1193.8
22	550	---	---	---	---	45.00	1143.0	---	---	---	---	51.00	1295.4
24	600	---	---	---	---	55.00	1397.0	---	---	---	---	55.00	1397.0
26	650	---	---	---	---	55.00	1397.0	---	---	---	---	57.00	1447.8
28	700	---	---	---	---	63.00	1600.2	---	---	---	---	63.00	1600.2
30	750	---	---	---	---	65.00	1651.0	---	---	---	---	65.00	1651.0
32	800	---	---	---	---	---	---	---	---	---	---	---	---
34	850	---	---	---	---	---	---	---	---	---	---	---	---
36	900	---	---	---	---	82.00	2082.8	---	---	---	---	82.00	2082.8

Figure 10.38 Steel Globe / Check Valve (Class 400 &amp; 600)

<b>Steel Globe and Check Valves / Dimensions Given in Inches and Millimeters (mm)</b> <i>(taken from Face-to-Face and End-to-End for Straightway Valves and Center-to-Face and Center-to-End for Angle Valves)</i>									
Nominal Pipe Size		Short Pattern							
		Beveled End / Class 600							
		Straightway Globe		Angle Globe		Swing Check		Control Valve Globe	
in	mm	in	mm	in	mm	in	mm	in	mm
1/2	15	---	---	---	---	---		8.00	203.2
3/4	20	---	---	---	---	---		8.12	206.3
1	25	5.25	133.4	---	---	5.25	133.4	8.25	209.6
1-1/4	32	5.75	146.1	---	---	5.75	146.1	---	---
1-1/2	40	6.00	152.4	---	---	6.00	152.4	9.88	251.0
2	50	7.00	177.8	4.25	108.0	7.00	177.8	11.25	285.8
2-1/2	65	8.50	215.9	5.00	127.0	8.50	215.9	12.25	311.2
3	80	10.00	254.0	6.00	152.4	10.00	254.0	13.25	336.6
4	100	12.00	304.8	7.00	177.8	12.00	304.8	15.50	393.7
5	125	15.00	381.0	8.50	215.9	15.00	381.0	---	---
6	150	18.00	457.2	10.00	254.0	18.00	457.2	20.00	508.0
8	200	23.00	584.2	---	---	23.00	584.2	24.00	609.6
10	250	28.00	711.2	---	---	28.00	711.2	29.62	752.4
12	300	32.00	812.8	---	---	32.00	812.2	32.25	819.2
14	350	---	---	---	---	---	---	38.25	971.6
16	400	---	---	---	---	---	---	43.62	1108.0
18	450	---	---	---	---	---	---	---	---
20	500	---	---	---	---	---	---	---	---
22	550	---	---	---	---	---	---	---	---
24	600	---	---	---	---	---	---	---	---
26	650	---	---	---	---	---	---	---	---
28	700	---	---	---	---	---	---	---	---
30	750	---	---	---	---	---	---	---	---
32	800	---	---	---	---	---	---	---	---
34	850	---	---	---	---	---	---	---	---
36	900	---	---	---	---	---	---	---	---

Figure 10.39 Steel Globe / Check Valve (Class 600)

<b>Steel Globe and Check Valves / Dimensions Given in Inches and Millimeters (mm)</b> <i>(taken from Face-to-Face and End-to-End for Straightway Valves and Center-to-Face and Center-to-End for Angle Valves)</i>													
<b>Steel Globe and Check Valves / ANSI Class 900</b>													
<b>Nominal Pipe Size</b>		<b>Long Pattern</b>						<b>Short Pattern</b>					
		<b>Raised Face and Beveled End / Class 900</b>						<b>Beveled End / Class 900</b>					
		<b>Straightway Globe</b>		<b>Angle Globe</b>		<b>Swing Check</b>		<b>Straightway Globe</b>		<b>Angle Globe</b>		<b>Swing Check</b>	
<b>in</b>	<b>mm</b>	<b>in</b>	<b>mm</b>	<b>in</b>	<b>mm</b>	<b>in</b>	<b>mm</b>	<b>in</b>	<b>mm</b>	<b>in</b>	<b>mm</b>	<b>in</b>	<b>mm</b>
1/2	15	---	---	---	---	---	---	---	---	---	---	---	---
3/4	20	9.00	228.6	4.50	114.3	9.00	228.6	---	---	---	---	---	---
1	25	10.00	254.0	5.00	127.0	10.00	254.0	---	---	---	---	---	---
1-¼	32	11.00	279.4	5.50	139.7	11.00	279.4	---	---	---	---	---	---
1-½	40	12.00	304.8	6.00	152.4	12.00	304.8	---	---	---	---	---	---
2	50	14.50	368.3	7.25	184.2	14.50	368.3	---	---	---	---	---	---
2-½	65	16.50	419.1	8.25	209.6	16.50	419.1	10.00	254.0	---	---	10.00	254.0
3	80	15.00	381.0	7.50	190.5	15.00	381.0	12.00	304.8	6.00	152.4	12.00	304.8
4	100	18.00	457.2	9.00	228.6	18.00	457.2	14.00	355.6	7.00	177.8	14.00	355.6
5	125	22.00	558.8	11.00	279.4	22.00	558.8	17.00	431.8	8.50	215.9	17.00	431.8
6	150	24.00	609.6	12.00	304.8	24.00	609.6	20.00	508.0	10.00	254.0	20.00	508.0
8	200	29.00	736.6	14.50	368.3	29.00	736.6	26.00	660.4	13.00	330.2	26.00	660.4
10	250	33.00	838.2	16.50	419.1	33.00	838.2	31.00	787.4	15.50	393.7	31.00	787.4
12	300	38.00	965.2	19.00	482.6	38.00	965.2	36.00	914.4	18.00	457.2	36.00	914.4
14	350	40.50	1028.7	20.25	514.4	40.50	1028.7	39.00	990.6	19.50	495.3	39.00	990.6
16	400	---	---	26.00	660.4	44.50	1130.3	43.00	1092.2	---	---	43.00	1092.2
18	450	---	---	29.00	736.6	48.00	1219.2	---	---	---	---	---	---
20	500	---	---	32.50	825.5	52.00	1320.8	---	---	---	---	---	---
22	550	---	---	---	---	---	---	---	---	---	---	---	---
24	600	---	---	39.00	990.6	61.00	1549.4	---	---	---	---	---	---

Figure 10.40 Steel Globe / Check Valve (Class 900)

<b>Steel Globe and Check Valves / Dimensions Given in Inches and Millimeters (mm)</b> <i>(taken from Face-to-Face and End-to-End for Straightway Valves and Center-to-Face and Center-to-End for Angle Valves)</i>											
<b>Steel Globe and Check Valves / ANSI Class 1500</b>											
<b>Nominal Pipe Size</b>		<b>Long Pattern</b>						<b>Short Pattern</b>			
		<b>Raised Face and Beveled End / Class 1500</b>						<b>Beveled End / Class 1500</b>			
		<b>Straightway Globe</b>		<b>Angle Globe</b>		<b>Swing Check</b>		<b>Straightway Globe</b>		<b>Swing Check</b>	
<b>in</b>	<b>mm</b>	<b>in</b>	<b>mm</b>	<b>in</b>	<b>mm</b>	<b>in</b>	<b>mm</b>	<b>in</b>	<b>mm</b>	<b>in</b>	<b>mm</b>
1/2	15	8.50	215.9	4.25	108.0	---	---	---	---	---	---
3/4	20	9.00	228.6	4.50	114.3	9.00	228.6	---	---	---	---
1	25	10.00	254.0	5.00	127.0	10.00	254.0	---	---	---	---
1-¼	32	11.00	279.4	5.50	139.7	11.00	279.4	---	---	---	---
1-½	40	12.00	304.8	6.00	152.4	12.00	304.8	---	---	---	---
2	50	14.50	368.3	7.25	184.2	14.50	368.3	8.50	215.9	8.50	215.9
2-½	65	16.50	419.1	8.25	209.6	16.50	419.1	10.00	254.0	10.00	254.0
3	80	18.50	469.9	9.25	235.0	18.50	469.9	12.00	304.8	12.00	304.8
4	100	21.50	546.1	10.75	273.1	21.50	546.1	16.00	406.4	16.00	406.4
5	125	26.50	673.1	13.25	336.6	26.50	673.1	19.00	482.6	19.00	482.6
6	150	27.75	704.9	13.88	352.6	27.75	704.9	22.00	558.8	22.00	558.8
8	200	32.75	831.9	16.38	416.1	32.75	831.9	28.00	711.2	28.00	711.2
10	250	39.00	990.6	19.50	495.3	39.00	990.6	34.00	863.6	34.00	863.6
12	300	44.50	1130.3	22.25	565.2	44.50	1130.3	39.00	990.6	39.00	990.6
14	350	49.50	1257.3	24.75	628.7	49.50	1257.3	42.00	1066.8	42.00	1066.8
16	400	---	---	---	---	54.50	1384.3	47.00	1193.8	47.00	1193.8
18	450	---	---	---	---	60.50	1536.7	---	---	---	---
20	500	---	---	---	---	65.50	1663.7	---	---	---	---
22	550	---	---	---	---	---	---	---	---	---	---
24	600	---	---	---	---	76.50	1943.1	---	---	---	---

Figure 10.41 Steel Globe / Check Valve (Class 1500)



<b>Steel Globe and Check Valves / Dimensions Given in Inches and Millimeters (mm)</b> (taken from Face-to-Face and End-to-End for Straightway Valves and Center-to-Face and Center-to-End for Angle Valves)											
<b>Steel Globe and Check Valves / ANSI Class 2500</b>											
Nominal Pipe Size		Long Pattern						Short Pattern			
		Raised Face and Beveled End / Class 2500						Beveled End / Class 2500			
		Straightway Globe		Angle Globe		Swing Check		Straightway Globe		Swing Check	
in	mm	in	mm	in	mm	in	mm	in	mm	in	mm
1/2	15	10.38	263.7	5.19	131.8	10.38	263.7	---	---	---	---
3/4	20	10.75	273.1	5.38	136.7	10.75	273.1	---	---	---	---
1	25	12.12	307.9	6.06	153.9	12.12	307.9	---	---	---	---
1-1/4	32	13.75	349.3	6.88	174.8	13.75	349.3	---	---	---	---
1-1/2	40	15.12	384.0	7.56	192.0	15.12	384.0	---	---	---	---
2	50	17.75	450.9	8.88	225.6	17.75	450.9	11.00	279.4	11.00	279.4
2-1/2	65	20.00	508.0	10.00	254.0	20.00	508.0	13.00	330.2	13.00	330.2
3	80	22.75	577.9	11.38	289.1	22.75	577.9	14.50	368.3	14.50	368.3
4	100	26.50	673.1	13.25	336.6	26.50	673.1	18.00	457.2	18.00	457.2
5	125	31.25	793.8	15.62	396.8	31.25	793.8	21.00	533.4	21.00	533.4
6	150	36.00	914.4	18.00	457.2	36.00	914.4	24.00	609.6	24.00	609.6
8	200	40.25	1022.4	20.12	511.1	40.25	1022.4	30.00	762.0	30.00	762.0
10	250	50.00	1270.0	25.00	635.0	50.00	1270.0	36.00	914.0	36.00	914.0
12	300	56.00	1422.4	28.00	711.2	56.00	1422.4	41.00	1041.4	41.00	1041.4
14	350	---	---	---	---	---	---	---	---	---	---
16	400	---	---	---	---	---	---	---	---	---	---
18	450	---	---	---	---	---	---	---	---	---	---

Notes

1. (---) Indicates valve size is not shown in ASME/ANSI standards but may be commercially available.
2. Millimeter dimensions are rounded off to first decimal point.
3. Dimensions based on ASME/ANSI B16.10 Standard.
4. Standard straightway lift check valve dimensions are interchangeable with straightway globe valve dimensions given above.
5. Angle lift check valve dimensions are interchangeable with angle globe valve dimensions given in tables.
6. Short pattern dimensions apply to pressure seal or flangeless bonnet valves (option on bolted bonnets).

Figure 10.42 Steel Globe / Check Valve (Class 2500)

# Chapter 11

## Solenoid Valves



## 11.1 Solenoid Valves

A solenoid-operated valve (SOV) is an on/off electro-magnetic valve that is controlled by a discrete electrical signal from a control system. In process control applications, SOVs are generally used to pressurize or de-pressurize on/off actuators. A three-way SOV is used for spring return actuator applications and a four-way SOV is used for double-acting actuator applications (see Figures 11.1 and 11.2).

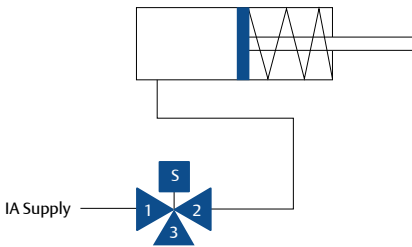

Figure 11.1 Spring-Return Actuator Diagram

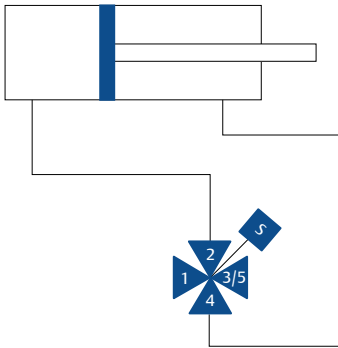

Figure 11.2 Double-Acting Actuator Diagram

Control valve applications will typically use a solenoid valve between the digital valve controller and the control valve (Figure 11.3). The SOV will remain energized while the control valve is being controlled by the digital valve controller. The digital valve controller pneumatic signal will pass through the SOV during normal operation. The SOV

is in place to allow quick shutdown of the control valve that is independent of the digital valve controller. The control valve can be put in the closed or safe state by either the solenoid valve or the digital valve controller. This type of arrangement is called a 1-out-of-2 (1oo2) arrangement. This nomenclature means that any 1 device of the 2 devices can put the control valve in its safe state. The devices are the digital valve controller and SOV.

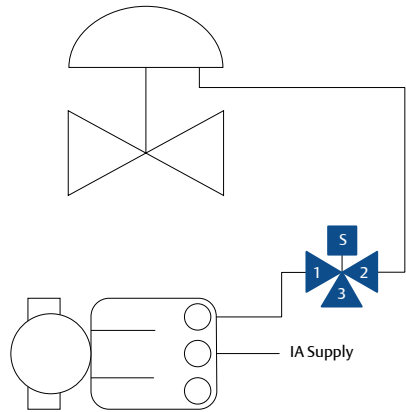

Figure 11.3 Solenoid Valve and Digital Valve Controller in a 1oo2 Configuration

When choosing an SOV for use in a control valve application, one must make sure that the SOV can operate over the entire pressure range of the control valve actuator and digital valve controller. The pressures for these applications may range from 0-150 psi depending upon the actuator type. In order to work effectively over this pressure range, a direct-acting SOV (Figure 11.4) or externally-piloted SOV (Figure 11.5) must be used. A direct-acting SOV is operated solely by the electro-magnetic force of the solenoid. An externally piloted SOV uses external air pressure to change the state of the SOV. The external air pressure is turned on and off by the direct-acting electro-magnetic

solenoid pilot that is part of the SOV. The external air pressure allows this type of SOV to change state without any air pressure in the main part of the SOV.



Figure 11.4 Direct-Acting Solenoid Valve Assembly



Figure 11.5 Pilot-Operated Solenoid Valve

There are multiple SOV architectures that can be used based upon the preference and need of the end user. See Figure 11.6 for a typical 1oo2 architecture that is used in systems where the need is for any 1 SOV to put the final control element in its safe state. See Figure 11.7 for a 2oo2 SOV architecture that requires both SOVs to put the final control element in its safe state. SOV architectures are available

in more complex configurations. The important aspect to remember about SOV architecture is the nomenclature specified as XooY has a specific meaning. Any X SOV(s) of the total Y SOV(s) must change state when demanded, in order to put the final control element in its safe state. A single solenoid used by itself is considered 1oo1.

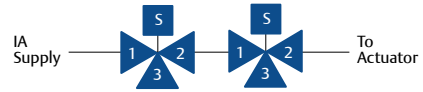

Figure 11.6 1oo2 Solenoid-Operated Valve Architecture

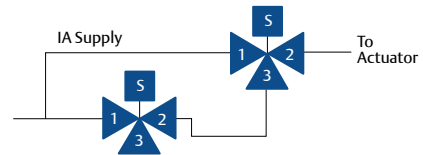

Figure 11.7 2oo2 Solenoid-Operated Valve Architecture

SOVs come in many different designs, from simple three-way direct-acting valves to more complicated manual reset valves and redundant solenoid systems. Manual reset SOVs (see Figure 11.9) are used when verification from an operator is needed prior to putting the SOV in service. Typically, the SOV is energized electrically but will not operate until an operator physically lifts a lever into place. Redundant SOV (see Figure 11.8) systems are used in critical applications to avoid spurious trips and/or to help ensure that a shutdown will occur when demanded in a final control element. ■



Figure 11.8 Redundant SOV



Figure 11.9 Three-Way Manual Reset SOV



Figure 11.10 SOV Manifold Assembly

# Chapter 12

## Safety Instrumented Systems





## 12.1 Safety and Layers of Protection

Safety is provided by layers of protection. These layers of protection start with effective process control, extend to manual and automatic safety prevention layers, and continue with layers to mitigate the consequences of an event.

The first layer is the basic process control system (BPCS). The process control system itself provides significant safety through proper design of process control.

The next layer of protection is also provided by the control system and the control system operators. Automated shutdown routines in the process control system combined with operator intervention to shut down the process are the next layer of safety.

Next is the safety instrumented system.

It is a safety system independent of the process control system. It has separate sensors, valves, and a logic solver. Its only role is safety. No process control is performed in this system.

Operator intervention and the safety instrumented system layers are designed to prevent a safety-related event. If a safety-related event occurs, there are additional layers designed to mitigate the impact of the event.

The next layer is an active protection layer. This layer may have valves or rupture disks designed to provide a relief point that prevents an uncontrolled release that can cause an explosion or fire.

The next layer is a passive protection layer. It may consist of a dike or other passive barrier that serves to contain a fire or channel the energy of an explosion in a direction that minimizes the spread of damage.

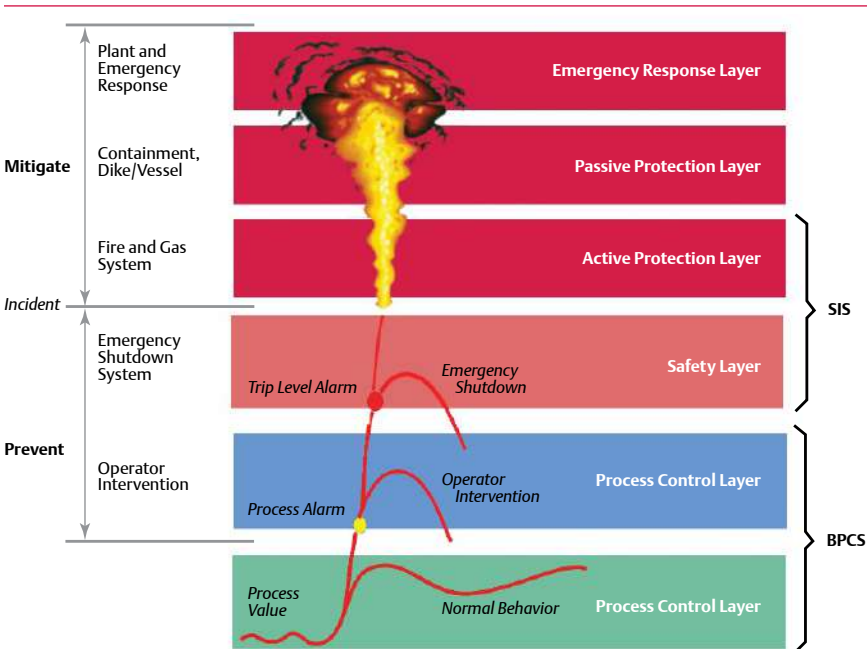

Figure 12.1 Layers of Protection

The final layer is plant and emergency response. If a large safety event occurs this layer responds in a way that minimizes ongoing damage, injury, or loss of life. It may include evacuation plans, firefighting, etc.

Overall safety is determined by how these layers work together. ■

## 12.2 Safety Instrumented Systems (SIS)

A safety instrumented system (SIS) is considered separate than the basic process control system (BPCS) in that the SIS is dedicated to taking the process to a “safe state” should a critical situation occur.

The SIS consists of several safety instrumented functions (SIF). Each safety instrumented function has a specified safety integrity level (SIL), which is necessary to achieve functional safety. Each SIF is a separate or interlinked loop comprised of sensors, logic solver (LS), and final control element (FE) as shown in Figure 12.2.

**Sensors:** Field sensors are used to collect information necessary to

determine if an emergency situation exists. The purpose of these sensors is to measure process parameters (i.e. temperature, pressure, flow, density etc.) to determine if the equipment or process is in a safe state. Sensor types range from simple pneumatic or electrical switches to smart transmitters with on-board diagnostics. These sensors are dedicated to SIS service and have process taps, which are separate and distinct from the process taps used by normal process information sensors.

**Logic Solver:** The purpose of this component of SIS is to determine what action is to be taken based on the information gathered. Highly reliable logic solvers are used which provide both fail-safe and fault-tolerant operation. It is typically a controller that reads signals from the sensors and executes pre-programmed actions to prevent a hazard by providing output to final control element(s). Logic solvers are very often programmable or non-programmable devices, but can also be mechanical in form of switched set to trip the safety function.

**Final Control Element:** Final control elements implement the action

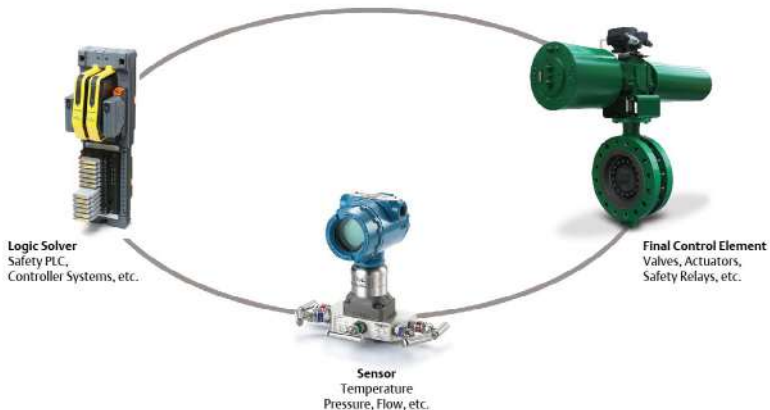

Figure 12.2 Components of a Safety Instrumented System (SIS)



determined by the logic solver. This final control element is typically an automated on/off valve, with a valve fail-closed or fail-open function.

It is imperative that all three elements of the SIS function as designed in order to safely isolate the process plant in the event of an emergency. ■

## 12.3 Safety Standards

In a process plant, there is no such thing as risk-free operation or 100% reliability. Therefore, one of the first tasks of the SIS designer is to perform a risk-tolerance analysis to determine what level of safety is needed. IEC Standard 61508 (Functional Safety of Electric, Electronic and Programmable Electronic Systems) is a general standard that covers functional safety related to all kinds of processing and manufacturing plans. IEC Standard 61511 and ISA S84.01 (Replaced by ISA 84.00.01-2004) are standards specific to the process industries. All three standards use a performance-based lifecycle model and specify precise levels of safety, best practices, and quantifiable proof of compliance. ■

## 12.4 Safety Integrity Level (SIL)

Safety integrity levels (SIL) are quantifiable measurement of risk. Since they were first introduced, safety integrity levels have been used as a quantifiable way to establish safety performance targets for SIS systems. IEC standards specify four possible Safety Integrity Levels (SIL 1, SIL 2, SIL 3, SIL 4) as shown in Figure 12.3; however, ISA S84.01 only recognizes up to SIL 3.

A determination of the target Safety Integrity Level requires:

- An identification of the hazards involved.
- Assessment of the risk of each of the identified hazards.
- An assessment of other Independent Protection Layers (IPLs) that may be in place.

Hazards can be identified using a number of different techniques; one common technique is a HAZard and OPerability study (HAZOP).

A risk factor must then be determined for each of the defined hazards, where risk is defined as a function of the probability (likelihood or frequency) and consequences (severity) of each

RRF (Risk Reduction Factor)	PFD <sub>avg</sub> (Probability of Failure on Demand = 1/RRF)	SIL (Safety Integrity Level)
100000 to 10000	$\geq 10^{-5}$ to $< 10^{-4}$	4
10000 to 1000	$\geq 10^{-4}$ to $< 10^{-3}$	3
1000 to 100	$\geq 10^{-3}$ to $< 10^{-2}$	2
100 to 10	$\geq 10^{-2}$ to $< 10^{-1}$	1

Figure 12.3 Safety Integrity Levels and Associated PFD<sub>avg</sub> and RRF Figures

hazardous event.

The HAZOP study is used to identify the risk to personnel or the environment and is carried out by a multi-disciplinary team (HAZOP team).

Once the risk is identified, the HAZOP/process hazard study (PHA) will set the requirement for risk reduction, thus define the required SIL Level.

Additional criteria need to be verified to ensure the SIF meets the required SIL, and they are often divided into the following points:

- Systematic integrity: All elements of the SIF need to be capable being used for the defined SIL level.
- Architectural constraints: Hardware Fault Tolerance (HFT) and redundancy of the architecture need to comply with current functional safety standards
- Random integrity (PFDavg): The failure rates of the individual devices will be used to calculate the average probability of failure on demand. ■

## 12.5 Probability of Failure Upon Demand

By understanding how the components of the SIS system can fail, it is possible to calculate a probability of failure on demand (PFD). There are two basic ways for the SIS to fail. The first way is commonly called a nuisance or spurious trip, which usually results in an unplanned but relatively safe process shutdown. While there is minimal danger associated with this type of SIS failure, the operational costs can be enormous. The second type of failure does not cause a process shutdown or nuisance trip. Instead, the failure remains undetected, permitting continued process operation in an unsafe and dangerous manner. If an emergency demand occurred, the SIS system

would be unable to respond properly.

These failures are known as covert or hidden failures and contribute to the probability (PFD) of the system failing in a dangerous manner on demand.

The PFD for the SIS system is the sum of PFDs for each element of the system:

$$PFD_{\text{total}} = PFD_{\text{sensor}} + PFD_{\text{logic solver}} + PFD_{\text{final element}}$$

In order to determine the PFD of each element, the analyst needs documented failure rate data for each element.

This failure rate (dangerous) is used in conjunction with the test interval (TI) term to calculate the PFD. It is this test interval that accounts for the length of time before a covert fault is discovered through testing. Increasing the test interval directly impacts the PFD value in a linear manner; i.e., if you double the interval between tests, you will double the probability for failure on demand, and make it twice as difficult to meet the target SIL.

The governing standards for safety instrumented systems state that plant operators must determine and document that equipment is designed, maintained, inspected, tested, and operated in a safe manner. Thus, it is imperative that these components of safety instrumented system be tested frequently enough to reduce the PFD and meet the target SIL. ■

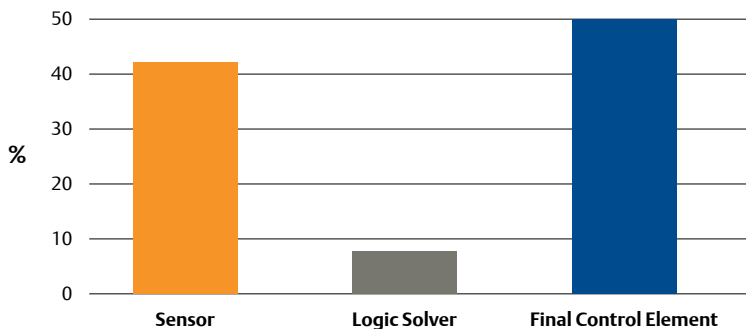

Figure 12.4 OREDA Data

## 12.6 Final Elements, Proof Testing, and Partial Stroke Testing Techniques

Final elements consist of valves, actuators, and valve instrumentation. Depending on the application ball, butterfly, or control valves are used for emergency shutdown (ESD), blowdown valves (BDV), or other use in a SIS to take the process to a safe state.

As final elements are only part of the SIF, it is difficult to confirm the required SIL without considering the initiator and logic solver as part of the loop. Statistical data available from the process industries can be used to provide an estimation of compliance with the required SIL. Data from OREDA (Offshore and Onshore Reliability Data) lists that as many as 50% of failures within a SIF can be attributed to the final element, as shown in Figure 12.4.

As final elements account for 50% of the failures, it is important that valves are selected that meet product design conditions, meet the required SIL target, and are tested periodically to ensure functionality. The SIS must be functionally tested with proof tests of each device on a periodic basis, as determined necessary during SIL verification analysis to maintain the

required SIL level for the SIF, throughout the lifecycle of the installation. A proof test for a final element would include a visual inspection and verification of safety function, which includes a full valve stroke and may also include a verification of safety time and valve leakage. ■

## 12.7 Partial Stroke Testing

At times, the duration between proof testing is not ideally aligned with scheduled shutdown or maintenance periods. To avoid shutting down the process for testing, a bypass around the final element can be used; however, testing with a bypass potentially leaves the process unprotected in the case of safety demand. An alternate option is to extend the proof test intervals by utilizing partial stroke testing (PST). Partial stroke testing exercises the valve a portion of its total travel to verify that the valve is not stuck and to uncover other otherwise dangerous undetected failure modes such as valve shaft sticking, valve packing issues, actuator air line issues, or other modes that could prevent the valve from moving to its safe position in the case of a safety demand.

The amount of time a proof test interval can be extended using partial stroke testing varies depending on SIL

target, test frequency, and amount of diagnostic coverage (a ratio between the failure rates detected to the total failure rate). ■

## 12.8 Online Testing Methods for the Final Element

Valve testing can be done by installing a bypass valve around each safety valve. By placing the bypass in service, the safety valve can be full stroke tested without shutting down the process.

In an attempt to eliminate the operational, economic, and regulatory problems associated with bypass testing, other methods were developed.

Mechanical limiting travel methods involve the use of some mechanical device such as a pin, a valve stem collar, a valve hand jack, etc. that will limit the valve travel to 15% or less of the valve stroke.

The pneumatic test panels method also uses a pin to engage before partial travel test could be initiated.

These online testing approaches have a number of disadvantages. A major drawback to these methods is that the safety shutdown function is not available during the test period. In fact, the process is left totally unprotected while the test is in progress, and for some areas and industries this type of testing will not be accepted. Also of concern is the possibility of the safety valve being inadvertently left in the bypass position after testing or the mechanical lock or pin is not removed after testing is complete. This would leave the process totally unprotected until such time as the error is discovered. In addition, these test methods all have a definite risk of spurious shutdown trips caused by testing. Another drawback is that the testing process must be manually initiated in the field and the tests

themselves are extremely manpower intensive and subject to error. ■

## 12.9 Digital Valve Controller Use for Partial Stroke Testing

Digital valve controllers are communicating, microprocessor-based current-to-pneumatic instruments with internal logic capability. In addition to the traditional function of converting a current signal to a pressure signal to operate the valve, these digital valve controllers use HART communications protocol to give easy access to information critical to safety testing. The digital valve controller receives feedback of the valve travel position plus supply and actuator pneumatic pressures. This allows the digital valve controller to diagnose the health and operation of itself and the valve and actuator to which it is mounted.

Partial stroke testing confirms the valve is working without disturbing the process. Since the entire test procedure can be programmed into the digital valve controller, partial stroke testing can be performed automatically. This allows the test interval to be as short as necessary (hourly, daily, weekly, etc.) to meet the target SIL values. The operator can manually initiate the test by a simple button push, however the testing sequence itself is completely automatic, thereby eliminating any errors and possible nuisance trips, and the labor capital cost of conventional testing schemes. If there is a safety demand during the partial stroke test, the test will be aborted and the digital valve controller will drive the valve to its safe state.

Typically, the partial stroke test moves the valve 10% from its original position but can be up to 30% if allowed by plant safety guidelines. Although partial

stroke testing does not eliminate the need for full stroke testing (full stroke testing is required to check valve seating, etc.) it does reduce the required full stroke testing frequency to the point where it can most likely be tested during plant turnaround.

Adding a digital valve controller to a safety instrumented system can reduce base equipment cost, testing time, and manpower requirements by eliminating the need for expensive pneumatic test panels and skilled personnel for testing. Using a digital valve controller can provide complete documentation of any emergency event as well as documentation of all testing, which could be made available to insurance companies as proof of testing. It also allows for configuration of remote testing, which can save time by reducing the requirement for maintenance inspection trips to the field. The safety of plant personnel can also be increased by eliminating the need for plant personnel to go to the field for testing. ■

## 12.10 High-Integrity Pressure Protection System (HIPPS)

High-integrity pressure protection systems (HIPPS) are part of the safety instrumented system and designed to prevent overpressure. Compared with conventional systems for pressure relief like the use of mechanical relief or safety valves, HIPPS work by shutting off the source and capturing the pressure in the upstream side of the system, thus providing a barrier between the high-pressure and low-pressure sides of a production facility. The tight shutoff will prevent downstream leakage and eliminate fugitive emissions. In this regard, HIPPS are seen as the “last line of defense.”

HIPPS offer an economical as well as environmental friendly solution compared with conventional relief systems. Figure 4 shows a typical HIPPS in a configuration set to meet SIL 3. ■

## 12.11 Functionality of the HIPPS

Like the SIF, a HIPPS typically consists of the following devices and functionality:

**Pressure Sensors:** Three individual pressure sensors on the upstream side of the HIPPS, set in a voting structure of 2 out of 3 (2oo3), will give the operator availability of the system + reliability to support the SIF.

**Logic Solver:** In the case that two out of three (2oo3) sensors measure a pressure higher than defined/allowed, the logic solver will shut down the two final elements and an alarm is sent to the control room.

**Final Elements:** Two isolation valves, in series (1oo2 arrangement) to provide redundancy and enhanced safety integrity. ■

## 12.12 Testing Requirements

To ensure the HIPPS will meet the required SIL throughout the safety lifecycle of the installation, testing will need to be done on the different elements:

**Pressure Sensor:** Pressure sensors will need to be taken out of service for testing, but as the configuration is 2oo3, it is possible to isolate 1 sensor for testing and maintain the same redundancy provided the voting in the logic solver is changed from 2oo3 to 1oo2. This is often done by an interlock system, providing a signal to the logic solver that a sensor is out for testing.

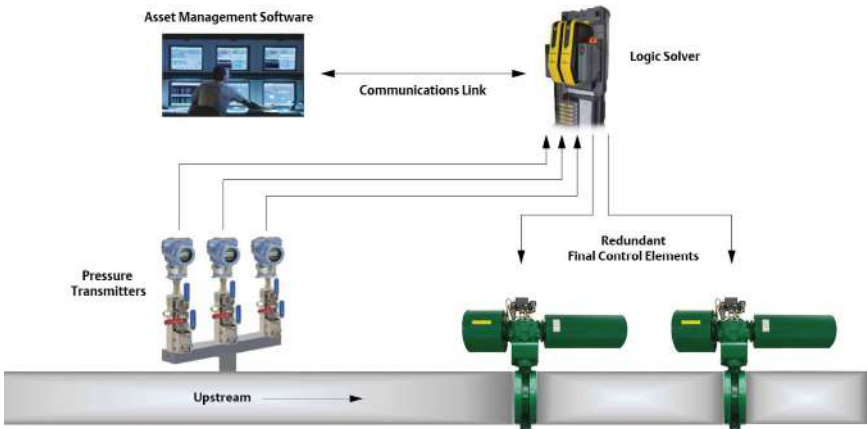

Figure 12.5 Typical HIPPS Configuration

**Logic Solver:** Logic solvers re often working with a dual processor and constantly running self-diagnostics. Should a failure be detected, it can be set to either shut down the final element or shift to a redundant logic solver.

**Final Control Element:** The governing standards for safety instrumented systems state that plant operators must determine and document that equipment is designed, maintained, inspected, tested, and operated in a safe manner. Thus it is imperative that these

components of the safety instrumented system be tested frequently enough to reduce the PFD and meet the target

**SIL:** A full stroke or proof test will need to be done with a set of intervals, but due to the nature of the test, this will need to be done out of service. To extend the period between the proof test, online testing like partial stroke testing can be used to detect a fair amount of failures plus give predictive diagnostic, allowing an operator to take action. ■



# Chapter 13

## Engineering Data





## 13.1 Standard Specifications for Pressure-Retaining Valve Materials

See section 13.2 for additional specifications, cross-referenced to Material Code numbers.

### 1. Cast Carbon Steel ASTM A216 Grade WCC:

Temperature range:  
 ■ -30 to 427°C (-20 to 800°F)

Composition (%):  
 ■ C = 0.25 max  
 ■ Mn = 1.2 max  
 ■ P = 0.035 max  
 ■ S = 0.035 max  
 ■ Si = 0.6 max

### 2. Cast Carbon Steel ASTM A352 Grade LCC:

Temperature range:  
 ■ -45 to 343°C (-50 to 650°F)

Composition (%):  
 ■ Same as ASTM A216 grade WCC

### 3. Carbon Steel Bar AISI 1018, UNS G10180:

Temperature range:  
 ■ -29 to 427°C (-20 to 800°F)

Composition (%):  
 ■ C = 0.14 to 0.2  
 ■ Mn = 0.6 to 0.9  
 ■ P = 0.04 max  
 ■ S = 0.05 max

### 4. Leaded Steel Bar AISI 12L14, UNS G12144:

Temperature range:  
 ■ -29 to 427°C (-20 to 800°F)

Composition (%):  
 ■ C = 0.15 max  
 ■ Mn = 0.85 to 1.15  
 ■ P = 0.04 to 0.09  
 ■ S = 0.26 to 0.35  
 ■ Pb = 0.15 to 0.35

### 5. AISI 4140 Cr-Mo Steel:

Similar to ASTM A193 Grade B7 bolt material.

Temperature range:  
 ■ -48 to 538°C (-55 to 1000°F)

Composition (%):  
 ■ C = 0.38 to 0.43  
 ■ Mn = 0.75 to 1.0  
 ■ P = 0.035 max  
 ■ S = 0.040 max  
 ■ Si = 0.15 to 0.35  
 ■ Cr = 0.8 to 1.1  
 ■ Mo = 0.15 to 0.25  
 ■ Fe = Remainder

### 6. Forged 3-1/2% Nickel Steel ASTM A352 Grade LC3:

Temperature range:  
 ■ -101 to 343°C (-150 to 650°F)

Composition (%):  
 ■ C = 0.15 max  
 ■ Mn = 0.5 to 0.8  
 ■ P = 0.04 max  
 ■ S = 0.045 max  
 ■ Si = 0.6 max  
 ■ Ni = 3.0 to 4.0

### 7. Cast Cr-Mo Steel ASTM A217 Grade WC6:

Temperature range:  
 ■ -30 to 595°C (-20 to 1100°F)

Composition (%):  
 ■ C = 0.05 to 0.2  
 ■ Mn = 0.5 to 0.8  
 ■ P = 0.035 max  
 ■ S = 0.035 max  
 ■ Si = 0.60 max  
 ■ Cr = 1.0 to 1.5  
 ■ Mo = 0.45 to 0.65

## 8. Cast Cr-Mo Steel ASTM A217 Grade WC9:

Temperature range:

- -30 to 595°C (-20 to 1100°F)

Composition (%):

- C = 0.05 to 0.18
- Mn = 0.4 to 0.7
- P = 0.035 max
- S = 0.035 max
- Si = 0.6 max
- Cr = 2.0 to 2.75
- Mo = 0.9 to 1.2

## 9. Forged Cr-Mo Steel ASTM A182 Grade F22:

Temperature range:

- -30 to 593°C (-20 to 1100°F)

Composition (%):

- C = 0.05 to 0.15
- Mn = 0.3 to 0.6
- P = 0.04 max
- S = 0.04 max
- Si = 0.5 max
- Cr = 2.0 to 2.5
- Mo = 0.87 to 1.13

## 10. Cast Cr-Mo Steel ASTM A217 Grade C5:

Temperature range:

- -30 to 649°C (-20 to 1200°F)

Composition (%):

- C = 0.2 max
- Mn = 0.4 to 0.7
- P = 0.04 max
- S = 0.045 max
- Si = 0.75 max
- Cr = 4.0 to 6.5
- Mo = 0.45 to 0.65

## 11. Type 302 Stainless Steel ASTM A479 Grade UNS S30200:

Temperature range:

- -198 to 399°C (-325 to 750°F)

Composition (%):

- C = 0.15 max
- Mn = 2.0 max
- P = 0.045 max
- S = 0.03 max
- Si = 1.0 max
- Cr = 17.0 to 19.0
- Ni = 8.0 to 10.0
- N = 0.1 max
- Fe = Remainder

## 12. Type 304L Stainless Steel ASTM A479 Grade UNS S30403:

Temperature range:

- -254 to 425°C (-425 to 800°F)

Composition (%):

- C = 0.03 max
- Mn = 2.0 max
- P = 0.045 max
- S = 0.03 max
- Si = 1.0 max
- Cr = 18.0 to 20.0
- Ni = 8.0 to 12.0
- Fe = Remainder

## 13. Cast Type 304L Stainless Steel ASTM A351 Grade CF3:

Temperature range:

- -254 to 425°C (-425 to 800°F)

Composition (%):

- C = 0.03 max
- Mn = 1.5 max
- Si = 2.0 max
- S = 0.040 max
- P = 0.040 max
- Cr = 17.0 to 21.0
- Ni = 8.0 to 11.0
- Mo = 0.50 max

#### 14. Type 316L Stainless Steel ASTM A479 Grade UNS S31603:

Temperature range:

- -254 to 450°C (-425 to 850°F)

Composition (%):

- C = 0.03 max
- Mn = 2.0 max
- P = 0.045 max
- S = 0.03 max
- Si = 1.0 max
- Cr = 16.0 to 18.0
- Ni = 10.0 to 14.0
- Mo = 2.0 to 3.0
- Fe = Remainder

#### 15. Type 316 Stainless Steel ASTM A479 Grade UNS S31600:

Temperature range:

- -255 to 816°C (-425 to 1500°F)
- Above 538°C (1000°F), 0.04 C minimum required

Composition (%):

- C = 0.08 max
- Mn = 2.0 max
- P = 0.045 max
- S = 0.03 max
- Si = 1.0 max
- Cr = 16.0 to 18.0
- Ni = 10.0 to 14.0
- Mo = 2.0 to 3.0
- Fe = Remainder

#### 16. Cast Type 316 Stainless Steel ASTM A351 Grade CF8M:

Temperature range:

- -254 to 816°C (-425 to 1500°F)
- Above 538°C (1000°F), 0.04 C minimum required

Composition (%):

- C = 0.08 max
- Mn = 1.5 max
- Si = 1.5 max
- P = 0.04 max
- S = 0.04 max
- Cr = 18.0 to 21.0
- Ni = 9.0 to 12.0
- Mo = 2.0 to 3.0

#### 17. Type 317 Stainless Steel ASTM A479 Grade UNS S31700:

Temperature range:

- -198 to 816°C (-325 to 1500°F)
- Above 538°C (1000°F), 0.04 C minimum required

Composition (%):

- C = 0.08 max
- Mn = 2.0 max
- P = 0.045 max
- S = 0.03 max
- Si = 1.0 max
- Cr = 18.0 to 20.0
- Ni = 11.0 to 15.0
- Mo = 3.0 to 4.0
- Fe = Remainder

#### 18. Cast Type 317 Stainless Steel ASTM A351 Grade CG8M:

Temperature range:

- -198 to 538°C (-325 to 1000°F)

Composition (%):

- C = 0.08 max
- Mn = 1.5 max
- Si = 1.5 max
- P = 0.04 max
- S = 0.04 max
- Cr = 18.0 to 21.0
- Ni = 9.0 to 13.0
- Mo = 3.0 to 4.0

#### 19. Type 410 Stainless Steel ASTM A479 Grade S41000:

Temperature range:

- -29 to 538°C (-20 to 1000°F)

Composition (%):

- C = 0.08 to 0.15
- Mn = 1.0 max
- P = 0.04 max
- S = 0.03 max
- Si = 1.0 max
- Cr = 11.5 to 13.5
- Fe = Remainder

**20. Type 17-4PH Stainless Steel ASTM A564 Grade 630, UNS S17400:**

Temperature range:

- -29 to 343°C (-20 to 650°F)

Composition (%):

- C = 0.07 max
- Mn = 1.0 max
- Si = 1.0 max
- P = 0.04 max
- S = 0.03 max
- Cr = 15.0 to 17.5
- Nb = 0.15 to 0.45
- Cu = 3.0 to 5.0
- Ni = 3.0 to 5.0
- Fe = Remainder

**21. Type 254 SMO Stainless Steel ASTM A479 Grade UNS S31254:**

Temperature range:

- -198 to 399°C (-325 to 750°F)

Composition (%):

- C = 0.02 max
- Mn = 1.0 max
- P = 0.03 max
- S = 0.01 max
- Si = 0.8 max
- Cr = 18.5 to 20.5
- Ni = 17.5 to 18.5
- Mo = 6.0 to 6.5
- N = 0.18–0.22
- Fe = Remainder

**22. Cast Type 254 SMO Stainless Steel ASTM A351 Grade CK3MCuN:**

Temperature range:

- -198 to 399°C (-325 to 750°F)

Composition (%):

- C = 0.025 max
- Mn = 1.2 max
- Si = 1.0 max
- P = 0.045 max
- S = 0.01 max
- Cr = 19.5 to 20.5
- Ni = 17.5 to 19.5
- Mo = 6.0 to 7.0
- N = 0.18 to 0.24

**23. Type 2205, S31803 Duplex Stainless Steel ASTM A479 Grade UNS S31803:**

Temperature range:

- -50 to 316°C (-60 to 600°F)

Composition (%):

- C = 0.03 max
- Mn = 2.0 max
- P = 0.03 max
- S = 0.02 max
- Si = 1.0 max
- Cr = 21.0 to 23.0
- Ni = 4.5 to 6.5
- Mo = 2.5 to 3.5
- N = 0.08 to 0.2
- Fe = Remainder

**24. Cast Type 2205, S31803 Stainless Steel ASTM A890 Grade 4a, CD3MN:**

Temperature range:

- -50 to 316°C (-60 to 600°F)

Composition (%):

- C = 0.03 max
- Mn = 1.5 max
- Si = 1.0 max
- P = 0.04 max
- S = 0.02 max
- Cr = 21.0 to 23.5
- Ni = 4.5 to 6.5
- Mo = 2.5 to 3.5
- Cu = 1.0 max
- N = 0.1 to 0.3
- Fe = Remainder

**25. Cast Iron ASTM A126 Class B, UNS F12102:**

Temperature range:

- -29 to 232°C (-20 to 450°F)

Composition (%):

- P = 0.75 max
- S = 0.15 max

**26. Cast Iron ASTM A126 Class C, UNS F12802:**

Temperature range:

- -29 to 232°C (-20 to 450°F)

Composition (%):

- $P = 0.75 \text{ max}$
- $S = 0.15 \text{ max}$

**27. Ductile Iron ASTM A395 Type 60-40-18:**

Temperature range:

- -29 to 343°C (-20 to 650°F)

Composition (%):

- $C = 3.0 \text{ min}$
- $Si = 2.5 \text{ max}$
- $P = 0.08 \text{ max}$

**28. Ductile Ni-Resist Iron ASTM A439 Type D-2B, UNS F43001:**

Temperature range for non-pressure-retaining components:

- -29 to 760°C (-20 to 1400°F)

Composition (%):

- $C = 3.0 \text{ max}$
- $Si = 1.5 \text{ to } 3.00$
- $Mn = 0.70 \text{ to } 1.25$
- $P = 0.08 \text{ max}$
- $Ni = 18.0 \text{ to } 22.0$
- $Cr = 2.75 \text{ to } 4.0$

**29. Valve Bronze ASTM B61, UNS C92200:**

Temperature range:

- -198 to 288°C (-325 to 550°F)

Composition (%):

- $Cu = 86.0 \text{ to } 90.0$
- $Sn = 5.5 \text{ to } 6.5$
- $Pb = 1.0 \text{ to } 2.0$
- $Zn = 3.0 \text{ to } 5.0$
- $Ni = 1.0 \text{ max}$
- $Fe = 0.25 \text{ max}$
- $S = 0.05 \text{ max}$
- $P = 0.05 \text{ max}$

**30. Tin Bronze ASTM B584 Grade UNS C90500:**

Temperature range:

- -198 to 204°C (-325 to 400°F)

Composition (%):

- $Cu = 86.0 \text{ to } 89.0$
- $Sn = 9.0 \text{ to } 11.0$
- $Pb = 0.30 \text{ max}$
- $Zn = 1.0 \text{ to } 3.0$
- $Ni = 1.0 \text{ max}$
- $Fe = 0.2 \text{ max}$
- $S = 0.05 \text{ max}$
- $P = 0.05 \text{ max}$

**31. Manganese Bronze ASTM B584 Grade UNS C86500:**

Temperature range:

- -198 to 177°C (-325 to 350°F)

Composition (%):

- $Cu = 55.0 \text{ to } 60.0$
- $Sn = 1.0 \text{ max}$
- $Pb = 0.4 \text{ max}$
- $Ni = 1.0 \text{ max}$
- $Fe = 0.4 \text{ to } 2.0$
- $Al = 0.5 \text{ to } 1.5$
- $Mn = 0.1 \text{ to } 1.5$
- $Zn = 36.0 \text{ to } 42.0$

**32. Cast Aluminum Bronze ASTM B148 Grade UNS C95400:**

Temperature range:

- -198 to 316°C (-325 to 600°F)

Composition (%):

- $Cu = 83.0 \text{ min}$
- $Al = 10.0 \text{ to } 11.5$
- $Fe = 3.0 \text{ to } 5.0$
- $Mn = 0.50 \text{ max}$
- $Ni = 1.5 \text{ max}$

**33. Cast Aluminum Bronze ASTM B148 Grade UNS C95800:**

Temperature range:

- -198 to 260°C (-325 to 500°F)

Composition (%):

- Cu = 79.0 min
- Al = 8.5 to 9.5
- Fe = 3.5 to 4.5
- Mn = 0.8 to 1.5
- Ni = 4.0 to 5.0
- Si = 0.1 max

**34. B16 Yellow Brass Bar ASTM B16 Grade UNS C36000, 1/2 Hard:**

Temperature range for non-pressure-retaining components:

- -198 to 204°C (-325 to 400°F)

Composition (%):

- Cu = 60.0 to 63.0
- Pb = 2.5 to 3.0
- Fe = 0.35 max
- Zn = Remainder

**35. Naval Brass Forgings ASTM B283 Alloy UNS C46400:**

Temperature range:

- -198 to 204°C (-325 to 400°F)

Composition (%):

- Cu = 59.0 to 62.0
- Sn = 0.5 to 1.0
- Pb = 0.2 max
- Fe = 0.15 max
- Zn = Remainder

**36. Aluminum Bar ASTM B211 Alloy UNS A96061-T6:**

Temperature range:

- -269 to 204°C (-452 to 400°F)

Composition (%):

- Si = 0.4 to 0.8
- Fe = 0.7 max
- Cu = 0.15 to 0.4
- Zn = 0.25 max
- Mg = 0.8 to 1.2
- Mn = 0.15 max
- Cr = 0.04 to 0.35
- Ti = 0.15 max
- Other Elements = 0.15 max
- Al = Remainder

**37. Cobalt-base Alloy No.6 Cast UNS R30006, Weld filler CoCr-A:**

Temperature range for non-pressure-retaining components:

- -198 to 980°C (-325 to 1800°F)

Composition (%):

- C = 0.9 to 1.4
- Mn = 1.0 max
- W = 3.5 to 6.0
- Ni = 3.0 max
- Cr = 26.0 to 31.0
- Mo = 1.5 max
- Fe = 3.0 max
- Si = 1.5 max
- Co = Remainder

**38. Ni-Cu Alloy Bar K500 ASTM B865 Grade N05500:**

Temperature range for non-pressure-retaining components:

- -198 to 482°C (-325 to 900°F)

Composition (%):

- Ni = 63.0 min
- Fe = 2.0 max
- Mn = 1.5 max
- Si = 0.5 max
- C = 0.18 max
- S = 0.01 max
- Al = 2.3 to 3.15
- Ti = 0.35 to 0.85
- Cu = Remainder

**39. Cast Ni-Cu Alloy 400 ASTM A494 Grade M35-1:**

Temperature range:

- -198 to 475°C (-325 to 900°F)

Composition (%):

- Cu = 27.0 to 33.0
- C = 0.35 max
- Mn = 1.5 max
- Fe = 3.5 max
- S = 0.02 max
- P = 0.03 max
- Si = 1.25 max
- Nb = 0.5 max
- Ni = Remainder

**40. Ni-Cr-Mo Alloy C276 Bar ASTM B574 Grade N10276:**

Temperature range:

- -198 to 677°C (-325 to 1250°F)

Composition (%):

- Cr = 14.5 to 16.5
- Fe = 4.0 to 7.0
- W = 3.0 to 4.5
- C = 0.01 max
- Si = 0.08 max
- Co = 2.5 max
- Mn = 1.0 max
- V = 0.35 max
- Mo = 15.0 to 17.0
- P = 0.04
- S = 0.03
- Ni = Remainder

**41. Ni-Cr-Mo Alloy C ASTM A494 CW2M:**

Temperature range:

- -198 to 538°C (-325 to 1000°F)

Composition (%):

- Cr = 15.5 to 17.5
- Fe = 2.0 max
- W = 1.0 max
- C = 0.02 max
- Si = 0.8 max
- Mn = 1.0 max
- Mo = 15.0 to 17.5
- P = 0.03
- S = 0.02
- Ni = Remainder

**42. Ni-Mo Alloy B2 Bar ASTM B335 Grade B2, UNS N10665:**

Temperature range:

- -198 to 427°C (-325 to 800°F)

Composition (%):

- Cr = 1.0 max
- Fe = 2.0 max
- C = 0.02 max
- Si = 0.1 max
- Co = 1.0 max
- Mn = 1.0 max
- Mo = 26.0 to 30.0
- P = 0.04 max
- S = 0.03 max
- Ni = Remainder

**43. Cast Ni-Mo Alloy B2 ASTM A494 N7M:**

Temperature range:

- -198 to 538°C (-325 to 1000°F)

Composition (%):

- Cr = 1.0 max
- Fe = 3.0 max
- C = 0.07 max
- Si = 1.0 max
- Mn = 1.0 max
- Mo = 30.0 to 33.0
- P = 0.03 max
- S = 0.02 max
- Ni = Remainder

## 13.2 Valve Material Properties for Pressure-Containing Components

The material codes in this table correspond to the Standard Specifications for Valve Materials listings in section 13.1.

Material Code	Minimum Mechanical Properties				Modulus of Elasticity at 21°C (70°F) psi (MPa)	Typical Brinell Hardness
	Tensile Strength ksi (MPa)	Yield Strength ksi (MPa)	Elongation in 2-inch (50 mm)	Reduction in Area (%)		
1	70-95 (485-655)	40 (275)	22	35	27.9E6 (19.2E4)	137-187
2	70-95 (485-655)	40 (275)	22	35	27.9E6 (19.2E4)	137-187
3	57 (390) typical	42 (290) typical	37 typical	67 typical	30.0E6 (20.7E4)	111
4	79 (545) typical	71 (490) typical	16 typical	52 typical	30.0E6 (20.7E4)	163
5 <sup>(1)</sup>	125 (860)	105 (725) typical	16	50	29.9E6 (20.6E4)	258
6	70-95 (485-655)	40 (275)	24	35	27.9E6 (19.2E4)	140-190
7	70-95 (485-655)	40 (275)	20	35	29.9E6 (20.6E4)	147-200
8	70-95 (485-655)	40 (275)	20	35	29.9E6 (20.6E4)	147-200
9	75-100 (515-690)	45(310)	19	40	29.9E6 (20.6E4)	156-207 required
10	90-115 (620-795)	60 (415)	18	35	27.4E6 (19.0E4)	176-255
11	75 (515)	30 (205)	30	40	28.3E6 (19.3E4)	150
12	70 (485)	25 (170)	30	40	29.0E6 (20.0E4)	150
13	70 (485)	30 (205)	35	---	29.0E6 (20.0E4)	150
14	70 (485)	25 (170)	40	50	28.3E6 (19.3E4)	150-170
15 <sup>(2)</sup>	75 (515)	30 (205)	30	40	28.3E6 (19.5E4)	150
16	70 (485)	30 (205)	30	---	28.3E6 (19.5E4)	163
17	75 (515)	30 (205)	30	40	28.3E6 (19.5E4)	170
18	75 (515)	35 (240)	25	---	28.3E6 (19.5E4)	170
19 <sup>(3)</sup>	70 (480)	40 (275)	20	45	29.2E6 (20.1E4)	241
20 <sup>(4)</sup>	145 (1000)	125 (860)	13	45	29E6 (20.0E4)	311 min
21	95 (665)	45 (310)	35	50	29.0E6 (20.0E4)	90 HRB
22	80 (550)	38 (260)	35	---	29.0E6 (20.0E4)	82 HRB
23	90 (620)	65 (450)	25	---	30.5E6 (21.0E4)	290 max
24	90 (620)	65 (450)	25	---	30.5E6 (21.0E4)	98 HRB



## Valve Material Properties for Pressure-Containing Components continued...

Material Code	Minimum Mechanical Properties				Modulus of Elasticity at 21°C (70°F) psi (MPa)	Typical Brinell Hardness
	Tensile Strength ksi (MPa)	Yield Strength ksi (MPa)	Elongation in 2-inch (50 mm)	Reduction in Area (%)		
25 <sup>(5)</sup>	31 (214)	---	---	---	13.4E6 (9.2E4)	160-220
26 <sup>(6)</sup>	41 (282)	---	---	---	13.4E6 (9.2E4)	230
27	60 (415)	40 (276)	18	---	23E6 (16E4)	143-187
28	58 (400)	30 (205)	8	---	---	139-202
29	34 (234)	16 (110)	24	---	14.0E6 (9.7E4)	65
30	40 (275)	18 (124)	20	---	14.0 (9.7E4)	75
31	65 (448)	25 (172)	20	---	15.3E6 (10.5E4)	97
32	75 (515)	30 (205)	12	---	16E6 (11.0E4)	150 min
33	85 (585)	35 (240)	15	---	16E6 (11.0E4)	159
34	55 (380)	25 (170)	10	---	14E6 (9.6E4)	55-75 HRB required
35	60 (415)	27 (185)	25	---	15.0E6 (10.3E4)	131-142
36	42 (290)	35 (241)	10	---	9.9E6 (6.8E4)	95
37 <sup>(7)</sup>	154 (1060) typical	93 (638) typical	17 typical	---	30E6 (21E4)	37 HRC
38	140 (965)	100 (690)	20	---	26E6 (17.9E4)	265-325
39	65 (450)	25 (170)	25	---	23E6 (15.8E4)	110-150
40	100 (689)	41 (283)	40	---	29.8E6 (20.5E4)	210
41	72 (496)	40 (275)	20	---	30.8E6 (21.2E4)	150-185
42	110 (760)	51 (350)	40	---	31.4E6 (21.7E4)	238
43	76 (525)	40 (275)	20	---	28.5E6 (19.7E4)	180

1. Tempered 650°C (1200°F).  
 2. Annealed.  
 3. ASTM A479 Annealed Condition  
 4. ASTM A564 Grade 630 Condition H1075  
 5. A126 Cl.B 1.125 in. (95 mm) dia bar.  
 6. A126 Cl.C 1.125 in. (95 mm) dia bar.  
 7. Wrought.

## 13.3 Physical Constants of Hydrocarbons

No.	Compound	Formula	Molecular Weight	Boiling Point at 14.696 psia (°F)	Vapor Pressure at 100°F (psia)	Freezing Point at 14.696 psia (°F)
1	Methane	CH <sub>4</sub>	16.043	-258.69	(5000) <sup>(2)</sup>	-296.46 <sup>(5)</sup>
2	Ethane	C <sub>2</sub> H <sub>6</sub>	30.070	-127.48	(800) <sup>(2)</sup>	-297.89 <sup>(5)</sup>
3	Propane	C <sub>3</sub> H <sub>8</sub>	44.097	-43.67	190	-305.84 <sup>(5)</sup>
4	n-Butane	C <sub>4</sub> H <sub>10</sub>	58.124	31.10	51.6	-217.05
5	Isobutane	C <sub>4</sub> H <sub>10</sub>	58.124	10.90	72.2	-255.29
6	n-Pentane	C <sub>5</sub> H <sub>12</sub>	72.151	96.92	15.570	-201.51
7	Isopentane	C <sub>5</sub> H <sub>12</sub>	72.151	82.12	20.44	-255.83
8	Neopentane	C <sub>5</sub> H <sub>12</sub>	72.151	49.10	35.90	2.17
9	n-Hexane	C <sub>6</sub> H <sub>14</sub>	86.178	155.72	4.956	-139.58
10	2-Methylpentane	C <sub>6</sub> H <sub>14</sub>	86.178	140.47	6.767	-244.63
11	3-Methylpentane	C <sub>6</sub> H <sub>14</sub>	86.178	145.89	6.098	- - -
12	Neohexane	C <sub>6</sub> H <sub>14</sub>	86.178	121.52	9.856	-147.72
13	2,3-Dimethylbutane	C <sub>6</sub> H <sub>14</sub>	86.178	136.36	7.404	-199.38

No.	Compound	Formula	Critical Constants		Specific Gravity at 14.696 psia	
			Critical Temp. (°F)	Critical Pressure (psia)	Liquid <sup>(3)(4)</sup> 60°F/60°F	Gas at 60°F (Air=1) <sup>(1)</sup>
1	Methane	CH <sub>4</sub>	-116.63	667.8	0.3 <sup>(8)</sup>	0.5539
2	Ethane	C <sub>2</sub> H <sub>6</sub>	90.09	707.8	0.3564 <sup>(7)</sup>	1.0382
3	Propane	C <sub>3</sub> H <sub>8</sub>	206.01	616.3	0.5077 <sup>(7)</sup>	1.5225
4	n-Butane	C <sub>4</sub> H <sub>10</sub>	305.65	550.7	0.5844 <sup>(7)</sup>	2.0068
5	Isobutane	C <sub>4</sub> H <sub>10</sub>	274.98	529.1	0.5631 <sup>(7)</sup>	2.0068
6	n-Pentane	C <sub>5</sub> H <sub>12</sub>	385.7	488.6	0.6310	2.4911
7	Isopentane	C <sub>5</sub> H <sub>12</sub>	369.10	490.4	0.6247	2.4911
8	Neopentane	C <sub>5</sub> H <sub>12</sub>	321.13	464.0	0.5967 <sup>(7)</sup>	2.4911
9	n-Hexane	C <sub>6</sub> H <sub>14</sub>	453.7	436.9	0.6640	2.9753
10	2-Methylpentane	C <sub>6</sub> H <sub>14</sub>	435.83	436.6	0.6579	2.9753
11	3-Methylpentane	C <sub>6</sub> H <sub>14</sub>	448.3	453.1	0.6689	2.9753
12	Neohexane	C <sub>6</sub> H <sub>14</sub>	420.13	446.8	0.6540	2.9753
13	2,3-Dimethylbutane	C <sub>6</sub> H <sub>14</sub>	440.29	453.5	0.6664	2.9753

## Physical Constants of Hydrocarbons continued...

No.	Compound	Formula	Molecular Weight	Boiling Point at 14.696 psia (°F)	Vapor Pressure at 100°F (psia)	Freezing Point at 14.696 psia (°F)
14	n-Heptane	C <sub>7</sub> H <sub>16</sub>	100.205	209.17	1.620	-131.05
15	2-Methylhexane	C <sub>7</sub> H <sub>16</sub>	100.205	194.09	2.271	-180.89
16	3-Methylhexane	C <sub>7</sub> H <sub>16</sub>	100.205	197.32	2.130	---
17	3-Ethylpentane	C <sub>7</sub> H <sub>16</sub>	100.205	200.25	2.012	-181.48
18	2,2-Dimethylpentane	C <sub>7</sub> H <sub>16</sub>	100.205	174.54	3.492	-190.86
19	2,4-Dimethylpentane	C <sub>7</sub> H <sub>16</sub>	100.205	176.89	3.292	-182.63
20	3,3-Dimethylpentane	C <sub>7</sub> H <sub>16</sub>	100.205	186.91	2.773	-210.01
21	Triptane	C <sub>7</sub> H <sub>16</sub>	100.205	177.58	3.374	-12.82
22	n-Octane	C <sub>8</sub> H <sub>18</sub>	114.232	258.22	0.537	-70.18
23	Diisobutyl	C <sub>8</sub> H <sub>18</sub>	114.232	228.39	1.101	-132.07
24	Isooctane	C <sub>8</sub> H <sub>18</sub>	114.232	210.63	1.708	-161.27
25	n-Nonane	C <sub>9</sub> H <sub>20</sub>	128.259	303.47	0.179	-64.28
26	n-Decane	C <sub>10</sub> H <sub>22</sub>	142.286	345.48	0.0597	-21.36
27	Cyclopentane	C <sub>5</sub> H <sub>10</sub>	70.135	120.65	9.914	-136.91
28	Methylcyclopentane	C <sub>6</sub> H <sub>12</sub>	84.162	161.25	4.503	-224.44

No.	Compound	Formula	Critical Constants		Specific Gravity at 14.696 psia	
			Critical Temp. (°F)	Critical Pressure (psia)	Liquid <sup>(3),(4)</sup> 60°F/60°F	Gas at 60°F (Air=1) <sup>(1)</sup>
14	n-Heptane	C <sub>7</sub> H <sub>16</sub>	512.8	396.8	0.6882	3.4596
15	2-Methylhexane	C <sub>7</sub> H <sub>16</sub>	495.00	396.5	0.6830	3.4596
16	3-Methylhexane	C <sub>7</sub> H <sub>16</sub>	503.78	408.1	0.6917	3.4596
17	3-Ethylpentane	C <sub>7</sub> H <sub>16</sub>	513.48	419.3	0.7028	3.4596
18	2,2-Dimethylpentane	C <sub>7</sub> H <sub>16</sub>	477.23	402.2	0.6782	3.4596
19	2,4-Dimethylpentane	C <sub>7</sub> H <sub>16</sub>	475.95	396.9	0.6773	3.4596
20	3,3-Dimethylpentane	C <sub>7</sub> H <sub>16</sub>	505.85	427.2	0.6976	3.4596
21	Triptane	C <sub>7</sub> H <sub>16</sub>	496.44	428.4	0.6946	3.4596
22	n-Octane	C <sub>8</sub> H <sub>18</sub>	564.22	360.6	0.7068	3.9439
23	Diisobutyl	C <sub>8</sub> H <sub>18</sub>	530.44	360.6	0.6979	3.9439
24	Isooctane	C <sub>8</sub> H <sub>18</sub>	519.46	372.4	0.6962	3.9439
25	n-Nonane	C <sub>9</sub> H <sub>20</sub>	610.68	332.	0.7217	4.4282
26	n-Decane	C <sub>10</sub> H <sub>22</sub>	652.1	304.	0.7342	4.9125
27	Cyclopentane	C <sub>5</sub> H <sub>10</sub>	461.5	653.8	0.7504	2.4215
28	Methylcyclopentane	C <sub>6</sub> H <sub>12</sub>	499.35	548.9	0.7536	2.9057

## Physical Constants of Hydrocarbons continued...

No.	Compound	Formula	Molecular Weight	Boiling Point at 14.696 psia (°F)	Vapor Pressure at 100°F (psia)	Freezing Point at 14.696 psia (°F)
29	Cyclohexane	C <sub>6</sub> H <sub>12</sub>	84.162	177.29	3.264	43.77
30	Methylcyclohexane	C <sub>7</sub> H <sub>14</sub>	98.189	213.68	1.609	-195.87
31	Ethylene	C <sub>2</sub> H <sub>4</sub>	28.054	-154.62	---	-272.45 <sup>(5)</sup>
32	Propene	C <sub>3</sub> H <sub>6</sub>	42.081	-53.90	226.4	-301.45 <sup>(5)</sup>
33	1-Butene	C <sub>4</sub> H <sub>8</sub>	56.108	20.75	63.05	-301.63 <sup>(5)</sup>
34	Cis-2-Butene	C <sub>4</sub> H <sub>8</sub>	56.108	38.69	45.54	-218.06
35	Trans-2-Butene	C <sub>4</sub> H <sub>8</sub>	56.108	33.58	49.80	-157.96
36	Isobutene	C <sub>4</sub> H <sub>8</sub>	56.108	19.59	63.40	-220.61
37	1-Pentene	C <sub>5</sub> H <sub>10</sub>	70.135	85.93	19.115	-265.39
38	1,2-Butadiene	C <sub>4</sub> H <sub>6</sub>	54.092	51.53	(20.) <sup>(2)</sup>	-213.16
39	1,3-Butadiene	C <sub>4</sub> H <sub>6</sub>	54.092	24.06	(60.) <sup>(2)</sup>	-164.02
40	Isoprene	C <sub>5</sub> H <sub>8</sub>	68.119	93.30	16.672	-230.74
41	Acetylene	C <sub>2</sub> H <sub>2</sub>	26.038	-119. <sup>(6)</sup>	---	-114. <sup>(5)</sup>
42	Benzene	C <sub>6</sub> H <sub>6</sub>	78.114	176.17	3.224	41.96
43	Toluene	C <sub>7</sub> H <sub>8</sub>	92.141	231.13	1.032	-138.94

No.	Compound	Formula	Critical Constants		Specific Gravity at 14.696 psia	
			Critical Temp. (°F)	Critical Pressure (psia)	Liquid <sup>(3),(4)</sup> 60°F/60°F	Gas at 60°F (Air=1) <sup>(1)</sup>
29	Cyclohexane	C <sub>6</sub> H <sub>12</sub>	536.7	591.	0.7834	2.9057
30	Methylcyclohexane	C <sub>7</sub> H <sub>14</sub>	570.27	503.5	0.7740	3.3900
31	Ethylene	C <sub>2</sub> H <sub>4</sub>	48.58	729.8	---	0.9686
32	Propene	C <sub>3</sub> H <sub>6</sub>	196.9	669.	0.5220 <sup>(7)</sup>	1.4529
33	1-Butene	C <sub>4</sub> H <sub>8</sub>	295.6	583.	0.6013 <sup>(7)</sup>	1.9372
34	Cis-2-Butene	C <sub>4</sub> H <sub>8</sub>	324.37	610.	0.6271 <sup>(7)</sup>	1.9372
35	Trans-2-Butene	C <sub>4</sub> H <sub>8</sub>	311.86	595.	0.6100 <sup>(7)</sup>	1.9372
36	Isobutene	C <sub>4</sub> H <sub>8</sub>	292.55	580.	0.6004 <sup>(7)</sup>	1.9372
37	1-Pentene	C <sub>5</sub> H <sub>10</sub>	376.93	590.	0.6457	2.4215
38	1,2-Butadiene	C <sub>4</sub> H <sub>6</sub>	(339.) <sup>(2)</sup>	(653.) <sup>(2)</sup>	0.6587	1.8676
39	1,3-Butadiene	C <sub>4</sub> H <sub>6</sub>	306.	628.	0.6272 <sup>(7)</sup>	1.8676
40	Isoprene	C <sub>5</sub> H <sub>8</sub>	(412.) <sup>(2)</sup>	(558.4) <sup>(2)</sup>	0.6861	2.3519
41	Acetylene	C <sub>2</sub> H <sub>2</sub>	95.31	890.4	0.615 <sup>(8)</sup>	0.8990
42	Benzene	C <sub>6</sub> H <sub>6</sub>	552.22	710.4	0.8844	2.6969
43	Toluene	C <sub>7</sub> H <sub>8</sub>	605.55	595.9	0.8718	3.1812

## Physical Constants of Hydrocarbons continued...

No.	Compound	Formula	Molecular Weight	Boiling Point at 14.696 psia (°F)	Vapor Pressure at 100°F (psia)	Freezing Point at 14.696 psia (°F)
44	Ethylbenzene	C <sub>8</sub> H <sub>10</sub>	106.168	277.16	0.371	-138.91
45	o-Xylene	C <sub>8</sub> H <sub>10</sub>	106.168	291.97	0.264	-13.30
46	m-Xylene	C <sub>8</sub> H <sub>10</sub>	106.168	282.41	0.326	-54.12
47	p-Xylene	C <sub>8</sub> H <sub>10</sub>	106.168	281.05	0.342	55.86
48	Styrene	C <sub>8</sub> H <sub>8</sub>	104.152	293.29	(0.24) <sup>(2)</sup>	-23.10
49	Isopropylbenzene	C <sub>9</sub> H <sub>12</sub>	120.195	306.34	0.188	-140.82

No.	Compound	Formula	Critical Constants		Specific Gravity at 14.696 psia	
			Critical Temp. (°F)	Critical Pressure (psia)	Liquid <sup>(3)(4)</sup> 60°F/60°F	Gas at 60°F (Air=1) <sup>(1)</sup>
44	Ethylbenzene	C <sub>8</sub> H <sub>10</sub>	651.24	523.5	0.8718	3.6655
45	o-Xylene	C <sub>8</sub> H <sub>10</sub>	675.0	541.4	0.8848	3.6655
46	m-Xylene	C <sub>8</sub> H <sub>10</sub>	651.02	513.6	0.8687	3.6655
47	p-Xylene	C <sub>8</sub> H <sub>10</sub>	649.6	509.2	0.8657	3.6655
48	Styrene	C <sub>8</sub> H <sub>8</sub>	706.0	580.	0.9110	3.5959
49	Isopropylbenzene	C <sub>9</sub> H <sub>12</sub>	676.4	465.4	0.8663	4.1498

1. Calculated values.
2. ( ) -Estimated values.
3. Air saturated hydrocarbons.
4. Absolute values from weights in vacuum.
5. At saturation pressure (triple point).
6. Sublimation point.
7. Saturation pressure and 15.5°C (60°F).
8. Apparent value for methane at 15.5°C (60°F).
9. Specific gravity, 119°F/60°F (sublimation point).

## 13.4 Specific Heat Ratio (k)

Gas	Specific Heat Ratio (k)	Gas	Specific Heat Ratio (k)	Gas	Specific Heat Ratio (k)	Gas	Specific Heat Ratio (k)
Acetylene	1.38	Carbon Dioxide	1.29	0.6 Natural Gas	1.32	Steam <sup>(1)</sup>	1.33
Air	1.40	Ethane	1.25	Nitrogen	1.40		
Argon	1.67	Helium	1.66	Oxygen	1.40		
Butane	1.17	Hydrogen	1.40	Propane	1.21		
Carbon Monoxide	1.40	Methane	1.26	Propylene	1.15		

1. Use property tables if available for greater accuracy.

## 13.5 Physical Constants of Various Fluids

Fluid	Formula	Molecular Weight	Boiling Point (°F at 14.696 psia)	Vapor Pressure at 70°F (psig)	Critical Temp. (°F)	Critical Pressure (psia)	Specific Gravity	
							Liquid (60/60 °F)	Gas
Acetic Acid	HC <sub>2</sub> H <sub>3</sub> O <sub>2</sub>	60.05	245	---	---	---	1.05	---
Acetone	C <sub>3</sub> H <sub>6</sub> O	58.08	133	---	455	691	0.79	2.01
Air	N <sub>2</sub> O <sub>2</sub>	28.97	-317	---	-221	547	0.86 <sup>(3)</sup>	1.0
Alcohol, Ethyl	C <sub>2</sub> H <sub>6</sub> O	46.07	173	2.3 <sup>(2)</sup>	470	925	0.794	1.59
Alcohol, Methyl	CH <sub>4</sub> O	32.04	148	4.63 <sup>(2)</sup>	463	1174	0.796	1.11
Ammonia	NH <sub>3</sub>	17.03	-28	114	270	1636	0.62	0.59
Ammonium Chloride <sup>(1)</sup>	NH <sub>4</sub> Cl	---	---	---	---	---	1.07	---
Ammonium Hydroxide <sup>(1)</sup>	NH <sub>4</sub> OH	---	---	---	---	---	0.91	---
Ammonium Sulfate <sup>(1)</sup>	(NH <sub>4</sub> ) <sub>2</sub> SO <sub>4</sub>	---	---	---	---	---	1.15	---
Aniline	C <sub>6</sub> H <sub>7</sub> N	93.12	365	---	798	770	1.02	---
Argon	A	39.94	-302	---	-188	705	1.65	1.38
Beer	---	---	---	---	---	---	1.01	---
Bromine	Br <sub>2</sub>	159.84	138	---	575	---	2.93	5.52
Calcium Chloride <sup>(1)</sup>	CaCl <sub>2</sub>	---	---	---	---	---	1.23	---
Carbon Dioxide	CO <sub>2</sub>	44.01	-109	839	88	1072	0.801 <sup>(3)</sup>	1.52
Carbon Disulfide	CS <sub>2</sub>	76.1	115	---	---	---	1.29	2.63
Carbon Monoxide	CO	28.01	-314	---	-220	507	0.80	0.97
Carbon Tetrachloride	CCl <sub>4</sub>	153.84	170	---	542	661	1.59	5.31
Chlorine	Cl <sub>2</sub>	70.91	-30	85	291	1119	1.42	2.45
Chromic Acid	H <sub>2</sub> CrO <sub>4</sub>	118.03	---	---	---	---	1.21	---
Citric Acid	C <sub>6</sub> H <sub>8</sub> O <sub>7</sub>	192.12	---	---	---	---	1.54	---
Copper Sulfate <sup>(1)</sup>	CuSO <sub>4</sub>	---	---	---	---	---	1.17	---
Ether	(C <sub>2</sub> H <sub>5</sub> ) <sub>2</sub> O	74.12	34	---	---	---	0.74	2.55
Ferric Chloride <sup>(1)</sup>	FeCl <sub>3</sub>	---	---	---	---	---	1.23	---
Fluorine	F <sub>2</sub>	38.00	-305	300	1200	809	1.11	1.31
Formaldehyde	H <sub>2</sub> CO	30.03	-6	---	---	---	0.82	1.08
Formic Acid	HCO <sub>2</sub> H	46.03	214	---	---	---	1.23	---
Furfural	C <sub>5</sub> H <sub>4</sub> O <sub>2</sub>	96.08	324	---	---	---	1.16	---
Glycerine	C <sub>3</sub> H <sub>8</sub> O <sub>3</sub>	92.09	554	---	---	---	1.26	---
Glycol	C <sub>2</sub> H <sub>6</sub> O <sub>2</sub>	62.07	387	---	---	---	1.11	---

## Physical Constants of Various Fluids continued...

Fluid	Formula	Molecular Weight	Boiling Point (°F at 14.696 psia)	Vapor Pressure at 70°F (psig)	Critical Temp. (°F)	Critical Pressure (psia)	Specific Gravity	
							Liquid (60/60 °F)	Gas
Helium	He	4.003	-454	---	-450	33	0.18	0.14
Hydrochloric Acid	HCl	36.47	-115	---	---	---	1.64	---
Hydrofluoric Acid	HF	20.01	66	0.9	446	---	0.92	---
Hydrogen	H <sub>2</sub>	2.016	-422	---	-400	188	0.07 <sup>(3)</sup>	0.07
Hydrogen Chloride	HCl	36.47	-115	613	125	1198	0.86	1.26
Hydrogen Sulfide	H <sub>2</sub> S	34.07	-76	252	213	1307	0.79	1.17
Isopropyl Alcohol	C <sub>3</sub> H <sub>8</sub> O	60.09	180	---	---	---	0.78	2.08
Linseed Oil	---	---	538	---	---	---	0.93	---
Mangesium Chloride <sup>(1)</sup>	MgCl <sub>2</sub>	---	---	---	---	---	1.22	---
Mercury	Hg	200.61	670	---	---	---	13.6	6.93
Methyl Bromide	CH <sub>3</sub> Br	94.95	38	13	376	---	1.73	3.27
Methyl Chloride	CH <sub>3</sub> Cl	50.49	-11	59	290	969	0.99	1.74
Naphthalene	C <sub>10</sub> H <sub>8</sub>	128.16	424	---	---	---	1.14	4.43
Nitric Acid	HNO <sub>3</sub>	63.02	187	---	---	---	1.5	---
Nitrogen	N <sub>2</sub>	28.02	-320	---	-233	493	0.81 <sup>(3)</sup>	0.97
Oil, Vegetable	---	---	---	---	---	---	0.91-0.94	---
Oxygen	O <sub>2</sub>	32	-297	---	-181	737	1.14 <sup>(3)</sup>	1.105
Phosgene	COCl <sub>2</sub>	98.92	47	10.7	360	823	1.39	3.42
Phosphoric Acid	H <sub>3</sub> PO <sub>4</sub>	98.00	415	---	---	---	1.83	---
Potassium Carbonate <sup>(1)</sup>	K <sub>2</sub> CO <sub>3</sub>	---	---	---	---	---	1.24	---
Potassium Chloride <sup>(1)</sup>	KCl	---	---	---	---	---	1.16	---
Potassium Hydroxide <sup>(1)</sup>	KOH	---	---	---	---	---	1.24	---
Sodium Chloride <sup>(1)</sup>	NaCl	---	---	---	---	---	1.19	---
Sodium Hydroxide <sup>(1)</sup>	NaOH	---	---	---	---	---	1.27	---
Sodium Sulfate <sup>(1)</sup>	Na <sub>2</sub> SO <sub>4</sub>	---	---	---	---	---	1.24	---
Sodium Thiosulfate <sup>(1)</sup>	Na <sub>2</sub> S <sub>2</sub> O <sub>3</sub>	---	---	---	---	---	1.23	---

## Physical Constants of Various Fluids continued...

Fluid	Formula	Molecular Weight	Boiling Point (°F at 14.696 psia)	Vapor Pressure at 70°F (psig)	Critical Temp. (°F)	Critical Pressure (psia)	Specific Gravity	
							Liquid (60/60 °F)	Gas
Starch	(C <sub>6</sub> H <sub>10</sub> O <sub>5</sub> ) <sub>x</sub>	---	---	---	---	---	1.50	---
Sugar Solutions <sup>(1)</sup>	C <sub>12</sub> H <sub>22</sub> O <sub>11</sub>	---	---	---	---	---	1.10	---
Sulfuric Acid	H <sub>2</sub> SO <sub>4</sub>	98.08	626	---	---	---	1.83	---
Sulfur Dioxide	SO <sub>2</sub>	64.6	14	34.4	316	1145	1.39	2.21
Turpentine	---	---	320	---	---	---	0.87	---
Water	H <sub>2</sub> O	18.016	212	0.9492 <sup>(2)</sup>	706	3208	1.00	0.62
Zinc Chloride <sup>(1)</sup>	ZnCl <sub>2</sub>	---	---	---	---	---	1.24	---
Zinc Sulfate <sup>(1)</sup>	ZnSO <sub>4</sub>	---	---	---	---	---	1.31	---

1. Aqueous Solution – 25% by weight of compound.  
2. Vapor pressure in psia at 39°C (100°F).  
3. Vapor pressure in psia.

## 13.6 Refrigerant 717 (Ammonia) Properties of Liquid and Saturated Vapor

Temp (°F)	Pressure		Volume (cu. ft./lb.)	Density (lb./cu. ft.)	Enthalpy <sup>(1)</sup> (BTU/lb.)		Entropy <sup>(1)</sup> BTU/(lb.)(°R)	
	psia	psig	Vapor (Vg)	Liquid (l/Vf)	Liquid (hf)	Vapor (hg)	Liquid (Sf)	Vapor (Sg)
-105	0.996	27.9 <sup>(2)</sup>	223.2	45.71	-68.5	570.3	-0.1774	1.6243
-104	1.041	27.8 <sup>(2)</sup>	214.2	45.67	-67.5	570.7	-0.1774	1.6205
-103	1.087	27.7 <sup>(2)</sup>	205.7	45.63	-66.4	571.2	-0.1714	1.6167
-102	1.135	27.6 <sup>(2)</sup>	197.6	45.59	-65.4	571.6	-0.1685	1.6129
-101	1.184	27.5 <sup>(2)</sup>	189.8	45.55	-64.3	572.1	-0.1655	1.6092
-100	1.24	27.4 <sup>(2)</sup>	182.4	45.52	-63.3	572.5	-0.1626	1.6055
-99	1.29	27.3 <sup>(2)</sup>	175.3	45.47	-62.2	572.9	-0.1597	1.6018
-98	1.34	27.2 <sup>(2)</sup>	168.5	45.43	-61.2	573.4	-0.1568	1.5982
-97	1.40	27.1 <sup>(2)</sup>	162.1	45.40	-60.1	573.8	-0.1539	1.5945
-96	1.46	26.9 <sup>(2)</sup>	155.9	45.36	-59.1	574.3	-0.1510	1.5910
-95	1.52	26.8 <sup>(2)</sup>	150.0	45.32	-58.0	574.7	-0.1481	1.5874
-94	1.59	26.7 <sup>(2)</sup>	144.3	45.28	-57.0	575.1	-0.1452	1.5838
-93	1.65	26.6 <sup>(2)</sup>	138.9	45.24	-55.9	575.6	-0.1423	1.5803
-92	1.72	26.4 <sup>(2)</sup>	133.8	45.20	-54.9	576.0	-0.1395	1.5768
-91	1.79	26.3 <sup>(2)</sup>	128.9	45.16	-53.8	576.5	-0.1366	1.5734



## Refrigerant 717 (Ammonia) Properties of Liquid and Saturated Vapor continued...

Temp (°F)	Pressure		Volume (cu. ft./lb.)	Density (lb./cu. ft.)	Enthalpy <sup>(1)</sup> (BTU/lb.)		Entropy <sup>(1)</sup> BTU/(lb.)(°R)	
	psia	psig	Vapor (Vg)	Liquid (l/Vf)	Liquid (hf)	Vapor (hg)	Liquid (Sf)	Vapor (Sg)
-90	1.86	26.1 <sup>(2)</sup>	124.1	45.12	-52.8	576.9	-0.1338	1.5699
-89	1.94	26.0 <sup>(2)</sup>	119.6	45.08	-51.7	577.3	-0.1309	1.5665
-88	2.02	25.8 <sup>(2)</sup>	115.3	45.04	-50.7	577.8	-0.1281	1.5631
-87	2.10	25.6 <sup>(2)</sup>	111.1	45.00	-49.6	578.2	-0.1253	1.5597
-86	2.18	25.5 <sup>(2)</sup>	107.1	44.96	-48.6	578.6	-0.1225	1.5564
-85	2.27	25.3 <sup>(2)</sup>	103.3	44.92	-47.5	579.1	-0.1197	1.5531
-84	2.35	25.1 <sup>(2)</sup>	99.68	44.88	-46.5	579.5	-0.1169	1.5498
-83	2.45	24.9 <sup>(2)</sup>	96.17	44.84	-45.4	579.9	-0.1141	1.5465
-82	2.54	24.7 <sup>(2)</sup>	92.81	44.80	-44.4	580.4	-0.1113	1.5432
-81	2.64	24.5 <sup>(2)</sup>	89.59	44.76	-43.3	580.8	-0.1085	1.5400
-80	2.74	24.3 <sup>(2)</sup>	86.50	44.73	-42.2	581.2	0.1057	1.5368
-79	2.84	24.1 <sup>(2)</sup>	83.54	44.68	-41.2	581.6	-0.1030	1.5336
-78	2.95	23.9 <sup>(2)</sup>	80.69	44.64	-40.1	582.1	-0.1002	1.5304
-77	3.06	23.7 <sup>(2)</sup>	77.96	44.60	-39.1	582.5	-0.0975	1.5273
-76	3.18	23.5 <sup>(2)</sup>	75.33	44.56	-38.0	582.9	-0.0947	1.5242
-75	3.29	23.2 <sup>(2)</sup>	72.81	44.52	-37.0	583.3	-0.0920	1.5211
-74	3.42	23.0 <sup>(2)</sup>	70.39	44.48	-35.9	583.8	-0.0892	1.5180
-73	3.54	22.7 <sup>(2)</sup>	68.06	44.44	-34.9	584.2	-0.0865	1.5149
-72	3.67	22.4 <sup>(2)</sup>	65.82	44.40	-33.8	584.6	-0.0838	1.5119
-71	3.80	22.2 <sup>(2)</sup>	63.67	44.36	-32.8	585.0	-0.0811	1.5089
-70	3.94	21.9 <sup>(2)</sup>	61.60	44.32	-31.7	585.5	-0.0784	1.5059
-69	4.08	21.6 <sup>(2)</sup>	59.61	44.28	-30.7	585.9	-0.0757	1.5029
-68	4.23	21.3 <sup>(2)</sup>	57.69	44.24	-29.6	586.3	-0.0730	1.4999
-67	4.38	21.0 <sup>(2)</sup>	55.85	44.19	-28.6	586.7	-0.0703	1.4970
-66	4.53	20.7 <sup>(2)</sup>	54.08	44.15	-27.5	587.1	-0.0676	1.4940
-65	4.69	20.4 <sup>(2)</sup>	52.37	44.11	-26.5	587.5	-0.0650	1.4911
-64	4.85	20.0 <sup>(2)</sup>	50.73	44.07	-25.4	588.0	-0.0623	1.4883
-63	5.02	19.7 <sup>(2)</sup>	49.14	44.03	-24.4	588.4	-0.0596	1.4854
-62	5.19	19.4 <sup>(2)</sup>	47.62	43.99	-23.3	588.8	-0.0570	1.4826
-61	5.37	19.0 <sup>(2)</sup>	46.15	43.95	-22.2	589.2	-0.0543	1.4797
-60	5.55	18.6 <sup>(2)</sup>	44.73	43.91	-21.2	589.6	-0.0517	1.4769
-59	5.74	18.2 <sup>(2)</sup>	43.37	43.87	-20.1	590.0	-0.0490	1.4741
-58	5.93	17.8 <sup>(2)</sup>	42.05	43.83	-19.1	590.4	-0.0464	1.4713
-57	6.13	17.4 <sup>(2)</sup>	40.79	43.78	-18.0	590.8	-0.0438	1.4686

## Refrigerant 717 (Ammonia) Properties of Liquid and Saturated Vapor continued...

Temp (°F)	Pressure		Volume (cu. ft./lb.)	Density (lb./cu. ft.)	Enthalpy <sup>(1)</sup> (BTU/lb.)		Entropy <sup>(1)</sup> BTU/(lb.)(°R)	
	psia	psig	Vapor (Vg)	Liquid (l/Vf)	Liquid (hf)	Vapor (hg)	Liquid (Sf)	Vapor (Sg)
-56	6.33	17.0 <sup>(2)</sup>	39.56	43.74	-17.0	591.2	-0.0412	1.4658
-55	6.54	16.6 <sup>(2)</sup>	38.38	43.70	-15.9	591.6	-0.0386	1.4631
-54	6.75	16.2 <sup>(2)</sup>	37.24	43.66	-14.8	592.1	-0.0360	1.4604
-53	6.97	15.7 <sup>(2)</sup>	36.15	43.62	-13.8	592.4	-0.0334	1.4577
-52	7.20	15.3 <sup>(2)</sup>	35.09	43.58	-12.7	592.9	-0.0307	1.4551
-51	7.43	14.8 <sup>(2)</sup>	34.06	43.54	-11.7	593.2	-0.0281	1.4524
-50	7.67	14.3 <sup>(2)</sup>	33.08	43.49	-10.6	593.7	-0.0256	1.4497
-49	7.91	13.8 <sup>(2)</sup>	32.12	43.45	-9.6	594.0	-0.0230	1.4471
-48	8.16	13.3 <sup>(2)</sup>	31.20	43.41	-8.5	594.4	-0.0204	1.4445
-47	8.42	12.8 <sup>(2)</sup>	30.31	43.37	-7.4	594.9	-0.0179	1.4419
-46	8.68	12.2 <sup>(2)</sup>	29.45	43.33	-6.4	595.2	-0.0153	1.4393
-45	8.95	11.7 <sup>(2)</sup>	28.62	43.28	-5.3	595.6	-0.0127	1.4368
-44	9.23	11.1 <sup>(2)</sup>	27.82	43.24	-4.3	596.0	-0.0102	1.4342
-43	9.51	10.6 <sup>(2)</sup>	27.04	43.20	-3.2	596.4	-0.0076	1.4317
-42	9.81	10.0 <sup>(2)</sup>	26.29	43.16	-2.1	596.8	-0.0051	1.4292
-41	10.10	9.3 <sup>(2)</sup>	25.56	43.12	-1.1	597.2	-0.0025	1.4267
-40	10.41	8.7 <sup>(2)</sup>	24.86	43.08	0.0	597.6	0.0000	1.4242
-39	10.72	8.1 <sup>(2)</sup>	24.18	43.04	1.1	598.0	0.0025	1.4217
-38	11.04	7.4 <sup>(2)</sup>	23.53	42.99	2.1	598.3	0.0051	1.4193
-37	11.37	6.8 <sup>(2)</sup>	22.89	42.95	3.2	598.7	0.0076	1.4169
-36	11.71	6.1 <sup>(2)</sup>	22.27	42.90	4.3	599.1	0.0101	1.4144
-35	12.05	5.4 <sup>(2)</sup>	21.68	42.86	5.3	599.5	0.0126	1.4120
-34	12.41	4.7 <sup>(2)</sup>	21.10	42.82	6.4	599.9	0.0151	1.4096
-33	12.77	3.9 <sup>(2)</sup>	20.54	42.78	7.4	600.2	0.0176	1.4072
-32	13.14	3.2 <sup>(2)</sup>	20.00	42.73	8.5	600.6	0.0201	1.4048
-31	13.52	2.4 <sup>(2)</sup>	19.48	42.69	9.6	601.0	0.0226	1.4025
-30	13.90	1.6 <sup>(2)</sup>	18.97	42.65	10.7	601.4	0.0250	1.4001
-29	14.30	0.8 <sup>(2)</sup>	18.48	42.61	11.7	601.7	0.0275	1.3978
-28	14.71	0.0	18.00	42.57	12.8	602.1	0.0300	1.3955
-27	15.12	0.4	17.54	42.54	13.9	602.5	0.0325	1.3932
-26	15.55	0.8	17.09	42.48	14.9	602.8	0.0350	1.3909
-25	15.98	1.3	16.66	42.44	16.0	603.2	0.0374	1.3886
-24	16.24	1.7	16.24	42.40	17.1	603.6	0.0399	1.3863
-23	16.88	2.2	15.83	42.35	18.1	603.9	0.0423	1.3840

## Refrigerant 717 (Ammonia) Properties of Liquid and Saturated Vapor continued...

Temp (°F)	Pressure		Volume (cu. ft./lb.)	Density (lb./cu. ft.)	Enthalpy <sup>(1)</sup> (BTU/lb.)		Entropy <sup>(1)</sup> BTU/(lb.)(°R)	
	psia	psig	Vapor (Vg)	Liquid (l/Vf)	Liquid (hf)	Vapor (hg)	Liquid (Sf)	Vapor (Sg)
-22	17.34	2.6	15.43	42.31	19.2	604.3	0.0448	1.3818
-21	17.81	3.1	15.05	42.26	20.3	604.6	0.0472	1.3796
-20	18.30	3.6	14.68	42.22	21.4	605.0	0.0497	1.3774
-19	18.79	4.1	14.32	42.18	22.4	605.3	0.0521	1.3752
-18	19.30	4.6	13.97	42.13	23.5	605.7	0.0545	1.3729
-17	19.81	5.1	13.62	42.09	24.6	606.1	0.0570	1.3708
-16	20.34	5.6	13.29	42.04	25.6	606.4	0.0594	1.3686
-15	20.88	6.2	12.97	42.00	26.7	606.7	0.0618	1.3664
-14	21.43	6.7	12.66	41.96	27.8	607.1	0.0642	1.3642
-13	21.99	7.3	12.36	41.91	28.9	607.5	0.0666	1.3624
-12	22.56	7.9	12.06	41.87	30.0	607.8	0.0690	1.3600
-11	23.15	8.5	11.78	41.82	31.0	608.1	0.0714	1.3579
-10	23.74	9.0	11.50	41.78	32.1	608.5	0.0738	1.3558
-9	24.35	9.7	11.23	41.74	33.2	608.8	0.0762	1.3537
-8	24.97	10.3	10.97	41.69	34.3	609.2	0.0786	1.3516
-7	25.61	10.9	10.71	41.65	35.4	609.5	0.0809	1.3493
-6	26.26	11.6	10.47	41.60	36.4	609.8	0.0833	1.3474
-5	26.92	12.2	10.23	41.56	37.5	610.1	0.0857	1.3454
-4	27.59	12.9	9.991	41.52	38.6	610.5	0.0880	1.3433
-3	28.28	13.6	9.763	41.47	39.7	610.8	0.0909	1.3413
-2	28.98	14.3	9.541	41.43	40.7	611.1	0.0928	1.3393
-1	29.69	15.0	9.326	41.38	41.8	611.4	0.0951	1.3372
0	30.42	15.7	9.116	41.34	42.9	611.8	0.0975	1.3352
1	31.16	16.5	8.912	41.29	44.0	612.1	0.0998	1.3332
2	31.92	17.2	8.714	41.25	45.1	612.4	0.1022	1.3312
3	32.69	18.0	8.521	41.20	46.2	612.7	0.1045	1.3292
4	33.47	18.8	8.333	41.16	47.2	613.0	0.1069	1.3273
5 <sup>(3)</sup>	34.27	19.6	8.150	41.11	48.3	613.3	0.1092	1.3253
6	35.09	20.4	7.971	41.07	49.4	613.6	0.1115	1.3234
7	35.92	21.2	7.798	41.01	50.5	613.9	0.1138	1.3214
8	36.77	22.1	7.629	40.98	51.6	614.3	0.1162	1.3195
9	37.63	22.9	7.464	40.93	52.7	614.6	0.1185	1.3176
10	38.51	23.8	7.304	40.89	53.8	614.9	0.1208	1.3157
11	39.40	24.7	7.148	40.84	54.9	615.2	0.1231	1.3137

## Refrigerant 717 (Ammonia) Properties of Liquid and Saturated Vapor continued...

Temp (°F)	Pressure		Volume (cu. ft./lb.)	Density (lb./cu. ft.)	Enthalpy <sup>(1)</sup> (BTU/lb.)		Entropy <sup>(1)</sup> BTU/(lb.)(°R)	
	psia	psig	Vapor (Vg)	Liquid (l/Vf)	Liquid (hf)	Vapor (hg)	Liquid (Sf)	Vapor (Sg)
12	40.31	25.6	6.996	40.80	56.0	615.5	0.1254	1.3118
13	41.24	26.5	6.847	40.75	57.1	615.8	0.1277	1.3099
14	42.18	27.5	6.703	40.71	58.2	616.1	0.1300	1.3081
15	43.14	28.4	6.562	40.66	59.2	616.3	0.1323	1.3062
16	44.12	29.4	6.425	40.61	60.3	616.6	0.1346	1.3043
17	45.12	30.4	6.291	40.57	61.4	616.9	0.1369	1.3025
18	46.13	31.4	6.161	40.52	62.5	617.2	0.1392	1.3006
19	47.16	32.5	6.034	40.48	63.6	617.5	0.1415	1.2988
20	48.21	33.5	5.910	40.43	64.7	617.8	0.1437	1.2969
21	49.28	34.6	5.789	40.38	65.8	618.0	0.1460	1.2951
22	50.36	35.7	5.671	40.34	66.9	618.3	0.1483	1.2933
23	51.47	36.8	5.556	40.29	68.0	618.6	0.1505	1.2915
24	52.59	37.9	5.443	40.25	69.1	618.9	0.1528	1.2897
25	53.73	39.0	5.334	40.20	70.2	619.1	0.1551	1.2879
26	54.90	40.2	5.227	40.15	71.3	619.4	0.1573	1.2861
27	56.08	41.4	5.123	40.10	72.4	619.7	0.1596	1.2843
28	57.28	42.6	5.021	40.06	73.5	619.9	0.1618	1.2823
29	58.50	43.8	4.922	40.01	74.6	620.2	0.1641	1.2809
30	59.74	45.0	4.825	39.96	75.7	620.5	0.1663	1.2790
31	61.00	46.3	4.730	39.91	76.8	620.7	0.1686	1.2773
32	62.29	47.6	4.637	39.86	77.9	621.0	0.1708	1.2755
33	63.59	48.9	4.547	39.82	79.0	621.2	0.1730	1.2738
34	64.91	50.2	4.459	39.77	80.1	621.5	0.1753	1.2721
35	66.26	51.6	4.373	39.72	81.2	621.7	0.1775	1.2704
36	67.63	52.9	4.289	39.67	82.3	622.0	0.1797	1.2686
37	69.02	54.3	4.207	39.63	83.4	622.2	0.1819	1.2669
38	70.43	55.7	4.126	39.58	84.6	622.5	0.1841	1.2652
39	71.87	57.2	4.048	39.54	85.7	622.7	0.1863	1.2635
40	73.32	58.6	3.971	39.49	86.8	623.0	0.1885	1.2618
41	74.80	60.1	3.897	39.44	87.9	623.2	0.1908	1.2602
42	76.31	61.6	3.823	39.39	89.0	623.4	0.1930	1.2585
43	77.83	63.1	3.752	39.34	90.1	623.7	0.1952	1.2568
44	79.38	64.7	3.682	39.29	91.2	623.9	0.1974	1.2552
45	80.96	66.3	3.614	39.24	92.3	624.1	0.1996	1.2535

## Refrigerant 717 (Ammonia) Properties of Liquid and Saturated Vapor continued...

Temp (°F)	Pressure		Volume (cu. ft./lb.)	Density (lb./cu. ft.)	Enthalpy <sup>(1)</sup> (BTU/lb.)		Entropy <sup>(1)</sup> BTU/(lb.)(°R)	
	psia	psig	Vapor (Vg)	Liquid (l/Vf)	Liquid (hf)	Vapor (hg)	Liquid (Sf)	Vapor (Sg)
46	82.55	67.9	3.547	39.19	93.5	624.4	0.2018	1.2518
47	84.18	69.5	3.481	39.14	94.6	624.6	0.2040	1.2492
48	85.82	71.1	3.418	39.10	95.7	624.8	0.2062	1.2484
49	87.49	72.8	3.355	39.05	96.8	625.0	0.2083	1.2469
50	89.19	74.5	3.294	39.00	97.9	625.2	0.2105	1.2453
51	90.91	76.2	3.234	38.95	99.1	625.5	0.2127	1.2437
52	92.66	78.0	3.176	38.90	100.2	625.7	0.2149	1.2421
53	94.43	79.7	3.119	38.85	101.3	625.9	0.2171	1.2405
54	96.23	81.5	3.063	38.80	102.4	626.1	0.2192	1.2382
55	98.06	83.4	3.008	38.75	103.5	626.3	0.2214	1.2372
56	99.91	85.2	2.954	38.70	104.7	626.5	0.2236	1.2357
57	101.8	87.1	2.902	38.65	105.8	626.7	0.2257	1.2341
58	103.7	89.0	2.851	38.60	106.9	626.9	0.2279	1.2325
59	105.6	90.9	2.800	38.55	108.1	627.1	0.2301	1.2310
60	107.6	92.9	2.751	38.50	109.2	627.3	0.2322	1.2294
61	109.6	94.9	2.703	38.45	110.3	627.5	0.2344	1.2273
62	111.6	96.9	2.656	38.40	111.5	627.7	0.2365	1.2263
63	113.6	98.9	2.610	38.35	112.6	627.9	0.2387	1.2247
64	115.7	101.0	2.565	38.30	113.7	628.0	0.2408	1.2231
65	117.8	103.1	2.520	38.25	114.8	628.2	0.2430	1.2213
66	120.0	105.3	2.477	38.20	116.0	628.4	0.2451	1.2201
67	122.1	107.4	2.435	38.15	117.1	628.6	0.2473	1.2183
68	124.3	109.6	2.393	38.10	118.3	628.8	0.2494	1.2179
69	126.5	111.8	2.352	38.05	119.4	628.9	0.2515	1.2155
70	128.8	114.1	2.312	38.00	120.5	629.1	0.2537	1.2140
71	131.1	116.4	2.273	37.95	121.7	629.3	0.2558	1.2125
72	133.4	118.7	2.235	37.90	122.8	629.4	0.2579	1.2110
73	135.7	121.0	2.197	37.84	124.0	629.6	0.2601	1.2095
74	138.1	123.4	2.161	37.79	125.1	629.8	0.2622	1.2080
75	140.5	125.8	2.125	37.74	126.2	629.9	0.2643	1.2065
76	143.0	128.3	2.089	37.69	127.4	630.1	0.2664	1.2050
77	145.4	130.7	2.055	37.64	128.5	630.2	0.2685	1.2035
78	147.9	133.2	2.021	37.58	129.7	630.4	0.2706	1.2020
79	150.5	135.8	1.988	37.53	130.8	630.5	0.2728	1.2006

## Refrigerant 717 (Ammonia) Properties of Liquid and Saturated Vapor continued...

Temp (°F)	Pressure		Volume (cu. ft./lb.)	Density (lb./cu. ft.)	Enthalpy <sup>(1)</sup> (BTU/lb.)		Entropy <sup>(1)</sup> BTU/(lb.)(°R)	
	psia	psig	Vapor (Vg)	Liquid (l/Vf)	Liquid (hf)	Vapor (hg)	Liquid (Sf)	Vapor (Sg)
80	153.0	138.3	1.955	37.48	132.0	630.7	0.2749	1.1991
81	155.6	140.9	1.923	37.43	133.1	630.8	0.2769	1.1976
82	158.3	143.6	1.892	37.37	134.3	631.0	0.2791	1.1962
83	161.0	146.3	1.861	37.32	135.4	631.1	0.2812	1.1947
84	163.7	149.0	1.831	37.26	136.6	631.3	0.2833	1.1933
85	166.4	151.7	1.801	37.21	137.8	631.4	0.2854	1.1918
86 <sup>(3)</sup>	169.2	154.5	1.772	37.16	138.9	631.5	0.2875	1.1904
87	172.0	157.3	1.744	37.11	140.1	631.7	0.2895	1.1889
88	174.8	160.1	1.716	37.05	141.2	631.8	0.2917	1.1875
89	177.7	163.0	1.688	37.00	142.4	631.9	0.2937	1.1860
90	180.6	165.9	1.661	36.95	143.5	632.0	0.2958	1.1846
91	183.6	168.9	1.635	36.89	144.7	632.1	0.2979	1.1832
92	186.6	171.9	1.609	36.84	145.8	632.2	0.3000	1.1818
93	189.6	174.9	1.584	36.78	147.0	632.3	0.3021	1.1804
94	192.7	178.0	1.559	36.73	148.2	632.5	0.3041	1.1789
95	195.8	181.1	1.534	36.67	149.4	632.6	0.3062	1.1775
96	198.9	184.2	1.510	36.62	150.5	632.6	0.3083	1.1761
97	202.1	187.4	1.487	36.56	151.7	632.8	0.3104	1.1747
98	205.3	190.6	1.464	36.51	152.9	632.9	0.3125	1.1733
99	208.6	193.9	1.441	36.45	154.0	632.9	0.3145	1.1719
100	211.9	197.2	1.419	36.40	155.2	633.0	0.3166	1.1705
101	215.2	200.5	1.397	36.34	156.4	633.1	0.3187	1.1691
102	218.6	203.9	1.375	36.29	157.6	633.2	0.3207	1.1677
103	222.0	207.3	1.354	36.23	158.7	633.3	0.3228	1.1663
104	225.4	210.7	1.334	36.18	159.9	633.4	0.3248	1.1649
105	228.9	214.2	1.313	36.12	161.1	633.4	0.3269	1.1635
106	232.5	217.8	1.293	36.06	162.3	633.5	0.3289	1.1621
107	236.0	221.3	1.274	36.01	163.5	633.6	0.3310	1.1607
108	239.7	225.0	1.254	35.95	164.6	633.6	0.3330	1.1593
109	243.3	228.6	1.235	35.90	165.8	633.7	0.3351	1.1580
110	247.0	232.3	1.217	35.84	167.0	633.7	0.3372	1.1566
111	250.8	236.1	1.198	35.78	168.2	633.8	0.3392	1.1552
112	254.5	239.8	1.180	35.72	169.4	633.8	0.3413	1.1538
113	258.4	243.7	1.163	35.67	170.6	633.9	0.3433	1.1524

## Refrigerant 717 (Ammonia) Properties of Liquid and Saturated Vapor continued...

Temp (°F)	Pressure		Volume (cu. ft./lb.)	Density (lb./cu. ft.)	Enthalpy <sup>(1)</sup> (BTU/lb.)		Entropy <sup>(1)</sup> BTU/(lb.)(°R)	
	psia	psig	Vapor (Vg)	Liquid (l/Vf)	Liquid (hf)	Vapor (hg)	Liquid (Sf)	Vapor (Sg)
114	262.2	247.5	1.145	35.61	171.8	633.9	0.3453	1.1510
115	266.2	251.5	1.128	35.55	173.0	633.9	0.3474	1.1497
116	270.1	255.4	1.112	35.49	174.2	634.0	0.3495	1.1483
117	274.1	259.4	1.095	35.43	175.4	634.0	0.3515	1.1469
118	278.2	263.5	1.079	35.38	176.6	634.0	0.3535	1.1455
119	282.3	267.6	1.063	35.32	177.8	634.0	0.3556	1.1441
120	286.4	271.7	1.047	35.26	179.0	634.0	0.3576	1.1427
121	290.6	275.9	1.032	35.20	180.2	634.0	0.3597	1.1414
122	294.8	280.1	1.017	35.14	181.4	634.0	0.3618	1.1400
123	299.1	284.4	1.002	35.08	182.6	634.0	0.3638	1.1386
124	303.4	288.7	0.987	35.02	183.9	634.0	0.3659	1.1372
125	307.8	293.1	0.973	34.96	185.1	634.0	0.3679	1.1358

1. Based on 0 for the saturated liquid at -40°C (-40°F).  
2. Inches of mercury below one standard atmosphere.  
3. Standard cycle temperatures.

## 13.7 Properties of Water

Temperature (°F)	Saturation Pressure (lb. per sq. in. absolute)	Weight (lb. per gallon)	Specific Gravity 60/60 °F	Conversion Factor <sup>(1)</sup> lbs./hr. to GPM
32	0.0885	8.345	1.0013	0.00199
40	0.1217	8.345	1.0013	0.00199
50	0.1781	8.340	1.0007	0.00199
60	0.2653	8.334	1.0000	0.00199
70	0.3631	8.325	0.9989	0.00200
80	0.5069	8.314	0.9976	0.00200
90	0.6982	8.303	0.9963	0.00200
100	0.9492	8.289	0.9946	0.00201
110	1.2748	8.267	0.9919	0.00201
120	1.6924	8.253	0.9901	0.00201
130	2.2225	8.227	0.9872	0.00202
140	2.8886	8.207	0.9848	0.00203
150	3.718	8.182	0.9818	0.00203
160	4.741	8.156	0.9786	0.00204
170	5.992	8.127	0.9752	0.00205

Properties of Water continued...

Temperature (°F)	Saturation Pressure (lb. per sq. in absolute)	Weight (lb. per gallon)	Specific Gravity 60/60 °F	Factor <sup>(1)</sup> lbs./hr. to GPM
180	7.510	8.098	0.9717	0.00205
190	9.339	8.068	0.9681	0.00206
200	11.526	8.039	0.9646	0.00207
210	14.123	8.005	0.9605	0.00208
212	14.696	7.996	0.9594	0.00208
220	17.186	7.972	0.9566	0.00209
240	24.969	7.901	0.9480	0.00210
260	35.429	7.822	0.9386	0.00211
280	49.203	7.746	0.9294	0.00215
300	67.013	7.662	0.9194	0.00217
350	134.63	7.432	0.8918	0.00224
400	247.31	7.172	0.8606	0.00232
450	422.6	6.892	0.8270	0.00241
500	680.8	6.553	0.7863	0.00254
550	1045.2	6.132	0.7358	0.00271
600	1542.9	5.664	0.6796	0.00294
700	3093.7	3.623	0.4347	0.00460

1. Multiply flow in pounds per hour by the factor to get equivalent flow in gallons per minute. Weight per gallon is based on 7.48 gallons per cubic foot.

## 13.8 Properties of Saturated Steam

Absolute Pressure		Vacuum (Inches of Hg)	Temperature (t) (°F)	Heat of the Liquid (BTU/lb.)	Latent Heat of Evaporation (BTU/lb.)	Total Heat of Steam Hg (BTU/lb.)	Specific Volume (Cu. ft./lb.)
Lbs per sq. in. P'	Inches of Hg						
0.20	0.41	29.51	53.14	21.21	1063.8	1085.0	1526.0
0.25	0.51	29.41	59.30	27.36	1060.3	1087.7	1235.3
0.30	0.61	29.31	64.47	32.52	1057.4	1090.0	1039.5
0.35	0.71	29.21	68.93	36.97	1054.9	1091.9	898.5
0.40	0.81	29.11	72.86	40.89	1052.7	1093.6	791.9
0.45	0.92	29.00	76.38	44.41	1050.7	1095.1	708.5
0.50	1.02	28.90	79.58	47.60	1048.8	1096.4	641.4
0.60	1.22	28.70	85.21	53.21	1045.7	1098.9	540.0
0.70	1.43	28.49	90.08	58.07	1042.9	1101.0	466.9
0.80	1.63	28.29	94.38	62.36	1040.4	1102.8	411.7



*Properties of Saturated Steam continued...*

Absolute Pressure		Vacuum (Inches of Hg)	Temperature (t) (°F)	Heat of the Liquid (BTU/lb.)	Latent Heat of Evaporation (BTU/lb.)	Total Heat of Steam Hg (BTU/lb.)	Specific Volume (Cu. ft./lb.)
Lbs per sq. in. P'	Inches of Hg						
0.90	1.83	28.09	98.24	66.21	1038.3	1104.5	368.4
1.0	2.04	27.88	101.74	69.70	1036.3	1106.0	333.6
1.2	2.44	27.48	107.92	75.87	1032.7	1108.6	280.9
1.4	2.85	27.07	113.26	81.20	1029.6	1110.8	243.0
1.6	3.26	26.66	117.99	85.91	1026.9	1112.8	214.3
1.8	3.66	26.26	122.23	90.14	1024.5	1114.6	191.8
2.0	4.07	25.85	126.08	93.99	1022.2	1116.2	173.73
2.2	4.48	25.44	129.62	97.52	1020.2	1117.7	158.85
2.4	4.89	25.03	132.89	100.79	1018.3	1119.1	146.38
2.6	5.29	24.63	135.94	103.83	1016.5	1120.3	135.78
2.8	5.70	24.22	138.79	106.68	1014.8	1121.5	126.65
3.0	6.11	23.81	141.48	109.37	1013.2	1122.6	118.71
3.5	7.13	22.79	147.57	115.46	1009.6	1125.1	102.72
4.0	8.14	21.78	152.97	120.86	1006.4	1127.3	90.63
4.5	9.16	20.76	157.83	125.71	1003.6	1129.3	81.16
5.0	10.18	19.74	162.24	130.13	1001.0	1131.1	73.52
5.5	11.20	18.72	166.30	134.19	998.5	1132.7	67.24
6.0	12.22	17.70	170.06	137.96	996.2	1134.2	61.98
6.5	13.23	16.69	173.56	141.47	994.1	1135.6	57.50
7.0	14.25	15.67	176.85	144.76	992.1	1136.9	53.64
7.5	15.27	14.65	179.94	147.86	990.2	1138.1	50.29
8.0	16.29	13.63	182.86	150.79	988.5	1139.3	47.34
8.5	17.31	12.61	185.64	153.57	986.8	1140.4	44.73
9.0	18.32	11.60	188.28	156.22	985.2	1141.4	42.40
9.5	19.34	10.58	190.80	158.75	983.6	1142.3	40.31
10.0	20.36	9.56	193.21	161.17	982.1	1143.3	38.42
11.0	22.40	7.52	197.75	165.73	979.3	1145.0	35.14
12.0	24.43	5.49	201.96	169.96	976.6	1146.6	32.40
13.0	26.47	3.45	205.88	173.91	974.2	1148.1	30.06
14.0	28.50	1.42	209.56	177.61	971.9	1149.5	28.04

*Properties of Saturated Steam continued...*

Pressure (Lbs. per sq. in.)		Temperature (t) (°F)	Heat of the Liquid (BTU/lb.)	Latent Heat of Evapor-ation (BTU/lb.)	Total Heat of Steam Hg (BTU/lb.)	Specific Volume (Cu. ft./lb.)
Absolute P'	Gauge P					
14.696	0.0	212.00	180.07	970.3	1150.4	26.80
15.0	0.3	213.03	181.11	969.7	1150.8	26.29
16.0	1.3	216.32	184.42	967.6	1152.0	24.75
17.0	2.3	219.44	187.56	965.5	1153.1	23.39
18.0	3.3	222.41	190.56	963.6	1154.2	22.17
19.0	4.3	225.24	193.42	961.9	1155.3	21.08
20.0	5.3	227.96	196.16	960.1	1156.3	20.089
21.0	6.3	230.57	198.79	958.4	1157.2	19.192
22.0	7.3	233.07	201.33	956.8	1158.1	18.375
23.0	8.3	235.49	203.78	955.2	1159.0	17.627
24.0	9.3	237.82	206.14	953.7	1159.8	16.938
25.0	10.3	240.07	208.42	952.1	1160.6	16.303
26.0	11.3	242.25	210.62	950.7	1161.3	15.715
27.0	12.3	244.36	212.75	949.3	1162.0	15.170
28.0	13.3	246.41	214.83	947.9	1162.7	14.663
29.0	14.3	248.40	216.86	946.5	1163.4	14.189
30.0	15.3	250.33	218.82	945.3	1164.1	13.746
31.0	16.3	252.22	220.73	944.0	1164.7	13.330
32.0	17.3	254.05	222.59	942.8	1165.4	12.940
33.0	18.3	255.84	224.41	941.6	1166.0	12.572
34.0	19.3	257.58	226.18	940.3	1166.5	12.226
35.0	20.3	259.28	227.91	939.2	1167.1	11.898
36.0	21.3	260.95	229.60	938.0	1167.6	11.588
37.0	22.3	262.57	231.26	936.9	1168.2	11.294
38.0	23.3	264.16	232.89	935.8	1168.7	11.015
39.0	24.3	265.72	234.48	934.7	1169.2	10.750
40.0	25.3	267.25	236.03	933.7	1169.7	10.498
41.0	26.3	268.74	237.55	932.6	1170.2	10.258
42.0	27.3	270.21	239.04	931.6	1170.7	10.029
43.0	28.3	271.64	240.51	930.6	1171.1	9.810
44.0	29.3	273.05	241.95	929.6	1171.6	9.601
45.0	30.3	274.44	243.36	928.6	1172.0	9.401
46.0	31.3	275.80	244.75	927.7	1172.4	9.209
47.0	32.3	277.13	246.12	926.7	1172.9	9.025

*Properties of Saturated Steam continued...*

Pressure (Lbs. per sq. in.)		Temperature (t) (°F)	Heat of the Liquid (BTU/lb.)	Latent Heat of Evapor-ation (BTU/lb.)	Total Heat of Steam Hg (BTU/lb.)	Specific Volume (Cu. ft./lb.)
Absolute P'	Gauge P					
48.0	33.3	278.45	247.47	925.8	1173.3	8.848
49.0	34.3	279.74	248.79	924.9	1173.7	8.678
50.0	35.3	281.01	250.09	924.0	1174.1	8.515
51.0	36.3	282.26	251.37	923.0	1174.4	8.359
52.0	37.3	283.49	252.63	922.2	1174.8	8.208
53.0	38.3	284.70	253.87	921.3	1175.2	8.062
54.0	39.3	285.90	255.09	920.5	1175.6	7.922
55.0	40.3	287.07	256.30	919.6	1175.9	7.787
56.0	41.3	288.23	257.50	918.8	1176.3	7.656
57.0	42.3	289.37	258.67	917.9	1176.6	7.529
58.0	43.3	290.50	259.82	917.1	1176.9	7.407
59.0	44.3	291.61	260.96	916.3	1177.3	7.289
60.0	45.3	292.71	262.09	915.5	1177.6	7.175
61.0	46.3	293.79	263.20	914.7	1177.9	7.064
62.0	47.3	294.85	264.30	913.9	1178.2	6.957
63.0	48.3	295.90	265.38	913.1	1178.5	6.853
64.0	49.3	296.94	266.45	912.3	1178.8	6.752
65.0	50.3	297.97	267.50	911.6	1179.1	6.655
66.0	51.3	298.99	268.55	910.8	1179.4	6.560
67.0	52.3	299.99	269.58	910.1	1179.7	6.468
68.0	53.3	300.98	270.60	909.4	1180.0	6.378
69.0	54.3	301.96	291.61	908.7	1180.3	6.291
70.0	55.3	302.92	272.61	907.9	1180.6	6.206
71.0	56.3	303.88	273.60	907.2	1180.8	6.124
72.0	57.3	304.83	274.57	906.5	1181.1	6.044
73.0	58.3	305.76	275.54	905.8	1181.3	5.966
74.0	59.3	306.68	276.49	905.1	1181.6	5.890
75.0	60.3	307.60	277.43	904.5	1181.9	5.816
76.0	61.3	308.50	278.37	903.7	1182.1	5.743
77.0	62.3	309.40	279.30	903.1	1182.4	5.673
78.0	63.3	310.29	280.21	902.4	1182.6	5.604
79.0	64.3	311.16	281.12	901.7	1182.8	5.537
80.0	65.3	312.03	282.02	901.1	1183.1	5.472
81.0	66.3	312.89	282.91	900.4	1183.3	5.408

*Properties of Saturated Steam continued...*

Pressure (Lbs. per sq. in.)		Temperature (t) (°F)	Heat of the Liquid (BTU/lb.)	Latent Heat of Evapor-ation (BTU/lb.)	Total Heat of Steam Hg (BTU/lb.)	Specific Volume (Cu. ft./lb.)
Absolute P'	Gauge P					
82.0	67.3	313.74	283.79	899.7	1183.5	5.346
83.0	68.3	314.59	284.66	899.1	1183.8	5.285
84.0	69.3	315.42	285.53	898.5	1184.0	5.226
85.0	70.3	316.25	286.39	897.8	1184.2	5.168
86.0	71.3	317.07	287.24	897.2	1184.4	5.111
87.0	72.3	317.88	288.08	896.5	1184.6	5.055
88.0	73.3	318.68	288.91	895.9	1184.8	5.001
89.0	74.3	319.48	289.74	895.3	1185.1	4.948
90.0	75.3	320.27	290.56	894.7	1185.3	4.896
91.0	76.3	321.06	291.38	894.1	1185.5	4.845
92.0	77.3	321.83	292.18	893.5	1185.7	4.796
93.0	78.3	322.60	292.98	892.9	1185.9	4.747
94.0	79.3	323.36	293.78	892.3	1186.1	4.699
95.0	80.3	324.12	294.56	891.7	1186.2	4.652
96.0	81.3	324.87	295.34	891.1	1186.4	4.606
97.0	82.3	325.61	296.12	890.5	1186.6	4.561
98.0	83.3	326.35	296.89	889.9	1186.8	4.517
99.0	84.3	327.08	297.65	889.4	1187.0	4.474
100.0	85.3	327.81	298.40	888.8	1187.2	4.432
101.0	86.3	328.53	299.15	888.2	1187.4	4.391
102.0	87.3	329.25	299.90	887.6	1187.5	4.350
103.0	88.3	329.96	300.64	887.1	1187.7	4.310
104.0	89.3	330.66	301.37	886.5	1187.9	4.271
105.0	90.3	331.36	302.10	886.0	1188.1	4.232
106.0	91.3	332.05	302.82	885.4	1188.2	4.194
107.0	92.3	332.74	303.54	884.9	1188.4	4.157
108.0	93.3	333.42	304.26	884.3	1188.6	4.120
109.0	94.3	334.10	304.97	883.7	1188.7	4.084
110.0	95.3	334.77	305.66	883.2	1188.9	4.049
111.0	96.3	335.44	306.37	882.6	1189.0	4.015
112.0	97.3	336.11	307.06	882.1	1189.2	3.981
113.0	98.3	336.77	307.75	881.6	1189.4	3.947
114.0	99.3	337.42	308.43	881.1	1189.5	3.914
115.0	100.3	338.07	309.11	880.6	1189.7	3.882

*Properties of Saturated Steam continued...*

Pressure (Lbs. per sq. in.)		Temperature (t) (°F)	Heat of the Liquid (BTU/lb.)	Latent Heat of Evapor-ation (BTU/lb.)	Total Heat of Steam Hg (BTU/lb.)	Specific Volume (Cu. ft./lb.)
Absolute P'	Gauge P					
116.0	101.3	338.72	309.79	880.0	1189.8	3.850
117.0	102.3	339.36	310.46	879.5	1190.0	3.819
118.0	103.3	339.99	311.12	879.0	1190.1	3.788
119.0	104.3	340.62	311.78	878.4	1190.2	3.758
120.0	105.3	341.25	312.44	877.9	1190.4	3.728
121.0	106.3	341.88	313.10	877.4	1190.5	3.699
122.0	107.3	342.50	313.75	876.9	1190.7	3.670
123.0	108.3	343.11	314.40	876.4	1190.8	3.642
124.0	109.3	343.72	315.04	875.9	1190.9	3.614
125.0	110.3	344.33	315.68	875.4	1191.1	3.587
126.0	111.3	344.94	316.31	874.9	1191.2	3.560
127.0	112.3	345.54	316.94	874.4	1191.3	3.533
128.0	113.3	346.13	317.57	873.9	1191.5	3.507
129.0	114.3	346.73	318.19	873.4	1191.6	3.481
130.0	115.3	347.32	318.81	872.9	1191.7	3.455
131.0	116.3	347.90	319.43	872.5	1191.9	3.430
132.0	117.3	348.48	320.04	872.0	1192.0	3.405
133.0	118.3	349.06	320.65	871.5	1192.1	3.381
134.0	119.3	349.64	321.25	871.0	1192.2	3.357
135.0	120.3	350.21	321.85	870.6	1192.4	3.333
136.0	121.3	350.78	322.45	870.1	1192.5	3.310
137.0	122.3	351.35	323.05	869.6	1192.6	3.287
138.0	123.3	351.91	323.64	869.1	1192.7	3.264
139.0	124.3	352.47	324.23	868.7	1192.9	3.242
140.0	125.3	353.02	324.82	868.2	1193.0	3.220
141.0	126.3	353.57	325.40	867.7	1193.1	3.198
142.0	127.3	354.12	325.98	867.2	1193.2	3.177
143.0	128.3	354.67	326.56	866.7	1193.3	3.155
144.0	129.3	355.21	327.13	866.3	1193.4	3.134
145.0	130.3	355.76	327.70	865.8	1193.5	3.114
146.0	131.3	356.29	328.27	865.3	1193.6	3.094
147.0	132.3	356.83	328.83	864.9	1193.8	3.074
148.0	133.3	357.36	329.39	864.5	1193.9	3.054
149.0	134.3	357.89	329.95	864.0	1194.0	3.034

*Properties of Saturated Steam continued...*

Pressure (lbs. per sq. in.)		Temperature (t) (°F)	Heat of the Liquid (BTU/lb.)	Latent Heat of Evapor-ation (BTU/lb.)	Total Heat of Steam Hg (BTU/lb.)	Specific Volume (Cu. ft./lb.)
Absolute P'	Gauge P					
150.0	135.3	358.42	330.51	863.6	1194.1	3.015
152.0	137.3	359.46	331.61	862.7	1194.3	2.977
154.0	139.3	360.49	332.70	861.8	1194.5	2.940
156.0	141.3	361.52	333.79	860.9	1194.7	2.904
158.0	143.3	362.53	334.86	860.0	1194.9	2.869
160.0	145.3	363.53	335.93	859.2	1195.1	2.834
162.0	147.3	364.53	336.98	858.3	1195.3	2.801
164.0	149.3	365.51	338.02	857.5	1195.5	2.768
166.0	151.3	366.48	339.05	856.6	1195.7	2.736
168.0	153.3	367.45	340.07	855.7	1195.8	2.705
170.0	155.3	368.41	341.09	854.9	1196.0	2.675
172.0	157.3	369.35	342.10	854.1	1196.2	2.645
174.0	159.3	370.29	343.10	853.3	1196.4	2.616
176.0	161.3	371.22	344.09	852.4	1196.5	2.587
178.0	163.3	372.14	345.06	851.6	1196.7	2.559
180.0	165.3	373.06	346.03	850.8	1196.9	2.532
182.0	167.3	373.96	347.00	850.0	1197.0	2.505
184.0	169.3	374.86	347.96	849.2	1197.2	2.479
186.0	171.3	375.75	348.92	848.4	1197.3	2.454
188.0	173.3	376.64	349.86	847.6	1197.5	2.429
190.0	175.3	377.51	350.79	846.8	1197.6	2.404
192.0	177.3	378.38	351.72	846.1	1197.8	2.380
194.0	179.3	379.24	352.64	845.3	1197.9	2.356
196.0	181.3	380.10	353.55	844.5	1198.1	2.333
198.0	183.3	380.95	354.46	843.7	1198.2	2.310
200.0	185.3	381.79	355.36	843.0	1198.4	2.288
205.0	190.3	383.86	357.58	841.1	1198.7	2.234
210.0	195.3	385.90	359.77	839.2	1199.0	2.183
215.0	200.3	387.89	361.91	837.4	1199.3	2.134
220.0	205.3	389.86	364.02	835.6	1199.6	2.087
225.0	210.3	391.79	366.09	833.8	1199.9	2.0422
230.0	215.3	393.68	368.13	832.0	1200.1	1.9992
235.0	220.3	395.54	370.14	830.3	1200.4	1.9579
240.0	225.3	397.37	372.12	828.5	1200.6	1.9183

*Properties of Saturated Steam continued...*

Pressure (lbs. per sq. in.)		Temperature (t) (°F)	Heat of the Liquid (BTU/lb.)	Latent Heat of Evapor-ation (BTU/lb.)	Total Heat of Steam Hg (BTU/lb.)	Specific Volume (Cu. ft./lb.)
Absolute P'	Gauge P					
245.0	230.3	399.18	374.08	826.8	1200.9	1.8803
250.0	235.3	400.95	376.00	825.1	1201.1	1.8438
255.0	240.3	402.70	377.89	823.4	1201.3	1.8086
260.0	245.3	404.42	379.76	821.8	1201.5	1.7748
265.0	250.3	406.11	381.60	820.1	1201.7	1.7422
270.0	255.3	407.78	383.42	818.5	1201.9	1.7107
275.0	260.3	409.43	385.21	816.9	1202.1	1.6804
280.0	265.3	411.05	386.98	815.3	1202.3	1.6511
285.0	270.3	412.65	388.73	813.7	1202.4	1.6228
290.0	275.3	414.23	390.46	812.1	1202.6	1.5954
295.0	280.3	415.79	392.16	810.5	1202.7	1.5689
300.0	285.3	417.33	393.84	809.0	1202.8	1.5433
320.0	305.3	423.29	400.39	803.0	1203.4	1.4485
340.0	325.3	428.97	406.66	797.1	1203.7	1.3645
360.0	345.3	434.40	412.67	791.4	1204.1	1.2895
380.0	365.3	439.60	418.45	785.8	1204.3	1.2222
400.0	385.3	444.59	424.0	780.5	1204.5	1.1613
420.0	405.3	449.39	429.4	775.2	1204.6	1.1061
440.0	425.3	454.02	434.6	770.0	1204.6	1.0556
460.0	445.3	458.50	439.7	764.9	1204.6	1.0094
480.0	465.3	462.82	444.6	759.9	1204.5	0.9670
500.0	485.3	467.01	449.4	755.0	1204.4	0.9278
520.0	505.3	471.07	454.1	750.1	1204.2	0.8915
540.0	525.3	475.01	458.6	745.4	1204.0	0.8578
560.0	545.3	478.85	463.0	740.8	1203.8	0.8265
580.0	565.3	482.58	467.4	736.1	1203.5	0.7973
600.0	585.3	486.21	471.6	731.6	1203.2	0.7698
620.0	605.3	489.75	475.7	727.2	1202.9	0.7440
640.0	625.3	493.21	479.8	722.7	1202.5	0.7198
660.0	645.3	496.58	483.8	718.3	1202.1	0.6971
680.0	665.3	499.88	487.7	714.0	1201.7	0.6757
700.0	685.3	503.10	491.5	709.7	1201.2	0.6554
720.0	705.3	506.25	495.3	705.4	1200.7	0.6362
740.0	725.3	509.34	499.0	701.2	1200.2	0.6180

*Properties of Saturated Steam continued...*

Pressure (lbs. per sq. in.)		Temperature (t) (°F)	Heat of the Liquid (BTU/lb.)	Latent Heat of Evapor-ation (BTU/lb.)	Total Heat of Steam Hg (BTU/lb.)	Specific Volume (Cu. ft./lb.)
Absolute P'	Gauge P					
760.0	745.3	512.36	502.6	697.1	1199.7	0.6007
780.0	765.3	515.33	506.2	692.9	1199.1	0.5843
800.0	785.3	518.23	509.7	688.9	1198.6	0.5687
820.0	805.3	521.08	513.2	684.8	1198.0	0.5538
840.0	825.3	523.88	516.6	680.8	1197.4	0.5396
860.0	845.3	526.63	520.0	676.8	1196.8	0.5260
880.0	865.3	529.33	523.3	672.8	1196.1	0.5130
900.0	885.3	531.98	526.6	668.8	1195.4	0.5006
920.0	905.3	534.59	529.8	664.9	1194.7	0.4886
940.0	925.3	537.16	533.0	661.0	1194.0	0.4772
960.0	945.3	539.68	536.2	657.1	1193.3	0.4663
980.0	965.3	542.17	539.3	653.3	1192.6	0.4557
1000.0	985.3	544.61	542.4	649.4	1191.8	0.4456
1050.0	1035.3	550.57	550.0	639.9	1189.9	0.4218
1100.0	1085.3	556.31	557.4	630.4	1187.8	0.4001
1150.0	1135.3	561.86	564.6	621.0	1185.6	0.3802
1200.0	1185.3	567.22	571.7	611.7	1183.4	0.3619
1250.0	1235.3	572.42	578.6	602.4	1181.0	0.3450
1300.0	1285.3	577.46	585.4	593.2	1178.6	0.3293
1350.0	1335.3	582.35	592.1	584.0	1176.1	0.3148
1400.0	1385.3	587.10	598.7	574.7	1173.4	0.3012
1450.0	1435.3	591.73	605.2	565.5	1170.7	0.2884
1500.0	1485.3	596.23	611.6	556.3	1167.9	0.2765
1600.0	1585.3	604.90	624.1	538.0	1162.1	0.2548
1700.0	1685.3	613.15	636.3	519.6	1155.9	0.2354
1800.0	1785.3	621.03	648.3	501.1	1149.4	0.2179
1900.0	1885.3	628.58	660.1	482.4	1142.4	0.2021
2000.0	1985.3	635.82	671.7	463.4	1135.1	0.1878
2100.0	2085.3	642.77	683.3	444.1	1127.4	0.1746
2200.0	2185.3	649.46	694.8	424.4	1119.2	0.1625
2300.0	2285.3	655.91	706.5	403.9	1110.4	0.1513
2400.0	2385.3	662.12	718.4	382.7	1101.1	0.1407
2500.0	2485.3	668.13	730.6	360.5	1091.1	0.1307
2600.0	2585.3	673.94	743.0	337.2	1080.2	0.1213



Properties of Saturated Steam continued...

Pressure (lbs. per sq. in.)		Temperature (t) (°F)	Heat of the Liquid (BTU/lb.)	Latent Heat of Evapor-ation (BTU/lb.)	Total Heat of Steam Hg (BTU/lb.)	Specific Volume (Cu. ft./lb.)
Absolute P'	Gauge P					
2700.0	2685.3	679.55	756.2	312.1	1068.3	0.1123
2800.0	2785.3	684.99	770.1	284.7	1054.8	0.1035
2900.0	2885.3	690.26	785.4	253.6	1039.0	0.0947
3000.0	2985.3	695.36	802.5	217.8	1020.3	0.0858
3100.0	3085.3	700.31	825.0	168.1	993.1	0.0753
3200.0	3185.3	705.11	872.4	62.0	934.4	0.0580
3206.2	3191.5	705.40	902.7	0.0	902.7	0.0503

## 13.9 Properties of Superheated Steam

$v$  = specific volume, cubic feet per pound;  $hg$  = total heat of steam, BTU per pound

Pressure (lbs. per sq. in.)		Sat. Temp. t	$v$ $hg$	Total Temperature (t) (°F)					
Absolute P'	Gauge P			360°	400°	440°	480°	500°	600°
14.696	0.0	212.00	$v$ $hg$	33.03 1221.1	34.68 1239.9	36.32 1258.8	37.96 1277.6	38.78 1287.1	42.86 1334.8
20.0	5.3	227.96	$v$ $hg$	24.21 1220.3	25.43 1239.2	26.65 1258.2	27.86 1277.1	28.46 1286.6	31.47 1334.4
30.0	15.3	250.33	$v$ $hg$	16.072 1218.6	16.897 1237.9	17.714 1257.0	18.528 1276.2	18.933 1285.7	20.95 1333.8
40.0	25.3	267.25	$v$ $hg$	12.001 1216.9	12.628 1236.5	13.247 1255.9	13.862 1275.2	14.168 1284.8	15.688 1333.1
50.0	35.3	281.01	$v$ $hg$	9.557 1215.2	10.065 1235.1	10.567 1254.7	11.062 1274.2	11.309 1283.9	12.532 1332.5

Pressure (lbs. per sq. in.)		Sat. Temp. t	$v$ $hg$	Total Temperature (t) (°F)				
Absolute P'	Gauge P			700°	800°	900°	1000°	1200°
14.696	0.0	212.00	$v$ $hg$	46.94 1383.2	51.00 1432.3	55.07 1482.3	59.13 1533.1	67.25 1637.5
20.0	5.3	227.96	$v$ $hg$	34.47 1382.9	37.46 1432.1	40.45 1482.1	43.44 1533.0	49.41 1637.4
30.0	15.3	250.33	$v$ $hg$	22.96 1382.4	24.96 1431.7	26.95 1481.8	28.95 1532.7	32.93 1637.2
40.0	25.3	267.25	$v$ $hg$	17.198 1381.9	18.702 1431.3	20.20 1481.4	21.70 1532.4	24.69 1637.0
50.0	35.3	281.01	$v$ $hg$	13.744 1381.4	14.950 1430.9	16.152 1481.1	17.352 1532.1	19.747 1636.8

## Properties of Superheated Steam continued...

Pressure (lbs. per sq. in.)		Sat. Temp. t	v hg	Total Temperature (t) (°F)					
Absolute P'	Gauge P			360°	400°	440°	480°	500°	600°
60.0	45.3	292.71	v hg	7.927 1213.4	8.357 1233.	8.779 1253.5	9.196 1273.2	9.403 1283.0	10.427 1331.8
70.0	55.3	302.92	v hg	6.762 1211.5	7.136 1232.1	7.502 1252.3	7.863 1272.2	8.041 1282.0	8.924 1331.1
80.0	65.3	312.03	v hg	5.888 1209.7	6.220 1230.7	6.544 1251.1	6.862 1271.1	7.020 1281.1	7.797 1330.5
90.0	75.3	320.27	v hg	5.208 1207.7	5.508 1229.1	5.799 1249.8	6.084 1270.1	6.225 1280.1	6.920 1329.8
100.0	85.3	327.81	v hg	4.663 1205.7	4.937 1227.6	5.202 1248.6	5.462 1269.0	5.589 1279.1	6.218 1329.1
120.0	105.3	341.25	v hg	3.844 1201.6	4.081 1224.4	4.307 1246.0	4.527 1266.90	4.636 1277.2	5.165 1327.7
140.0	125.3	353.02	v hg	3.258 1197.3	3.468 1221.1	3.667 1243.3	3.860 1264.7	3.954 1275.2	4.413 1326.4
160.0	145.3	363.53	v hg	--- ---	3.008 1217.6	3.187 1240.6	3.359 1262.4	3.443 1273.1	3.849 1325.0
180.0	165.3	373.06	v hg	--- ---	2.649 1214.0	2.813 1237.8	2.969 1260.2	3.044 1271.0	3.411 1323.5

Pressure (lbs. per sq. in.)		Sat. Temp. t	v hg	Total Temperature (t) (°F)				
Absolute P'	Gauge P			700°	800°	900°	1000°	1200°
60.0	45.3	292.71	v hg	11.441 1380.9	12.449 1430.5	13.452 1480.8	14.454 1531.9	16.451 1636.6
70.0	55.3	302.92	v hg	9.796 1380.4	10.662 1430.1	11.524 1480.5	12.383 1531.6	14.097 1636.3
80.0	65.3	312.03	v hg	8.562 1379.9	9.322 1429.7	10.077 1480.1	10.830 1531.3	12.332 1636.2
90.0	75.3	320.27	v hg	7.603 1379.4	8.279 1429.3	8.952 1479.8	9.623 1531.0	10.959 1635.9
100.0	85.3	327.81	v hg	6.835 1378.9	7.446 1428.9	8.052 1479.5	8.656 1530.8	9.860 1635.7
120.0	105.3	341.25	v hg	5.683 1377.8	6.195 1428.1	6.702 1478.8	7.207 1530.2	8.212 1635.3
140.0	125.3	353.02	v hg	4.861 1376.8	5.301 1427.3	5.738 1478.2	6.172 1529.7	7.035 1634.9
160.0	145.3	363.53	v hg	4.244 1375.7	4.631 1426.4	5.015 1477.5	5.396 1529.1	6.152 1634.5
180.0	165.3	373.06	v hg	3.764 1374.7	4.110 1425.6	4.452 1476.8	4.792 1528.6	5.466 1634.1

## Properties of Superheated Steam continued...

Pressure (lbs. per sq. in.)		Sat. Temp. t	v hg	Total Temperature (t) (°F)					
Absolute p'	Gauge P			360°	400°	440°	480°	500°	600°
200.0	185.3	381.79	v hg	--- ---	2.361 1210.3	2.513 1234.9	2.656 1257.8	2.726 1268.9	3.060 1322.1
220.0	205.3	389.86	v hg	--- ---	2.125 1206.5	2.267 1231.9	2.400 1255.4	2.465 1266.7	2.772 1320.7
240.0	225.3	397.37	v hg	--- ---	1.9276 1202.5	2.062 1228.8	2.187 1253.0	2.247 1264.5	2.533 1319.2
260.0	245.3	404.42	v hg	--- ---	---	1.8882 1225.7	2.006 1250.5	2.063 1262.3	2.330 1317.7
280.0	265.3	411.05	v hg	--- ---	---	1.7388 1222.4	1.8512 1247.9	1.9047 1260.0	2.156 1316.2
300.0	285.3	417.33	v hg	--- ---	---	1.6090 1219.1	1.7165 1245.3	1.7675 1257.6	2.005 1314.7
320.0	305.3	423.29	v hg	--- ---	---	1.4950 1215.6	1.5985 1242.6	1.6472 1255.2	1.8734 1313.2
340.0	325.3	428.97	v hg	--- ---	---	1.3941 1212.1	1.4941 1239.9	1.5410 1252.8	1.7569 1311.6
360.0	345.3	434.40	v hg	--- ---	---	1.3041 1208.4	1.4012 1237.1	1.4464 1250.3	1.6533 1310.1

Pressure (lbs. per sq. in.)		Sat. Temp. t	v hg	Total Temperature (t) (°F)				
Absolute p'	Gauge P			700°	800°	900°	1000°	1200°
200.0	185.3	381.79	v hg	3.380 1373.6	3.693 1424.8	4.002 1476.2	4.309 1528.0	4.917 1633.7
220.0	205.3	389.86	v hg	3.066 1372.6	3.352 1424.0	3.634 1475.5	3.913 1527.5	4.467 1633.3
240.0	225.3	397.37	v hg	2.804 1371.5	3.068 1423.2	3.327 1474.8	3.584 1526.9	4.093 1632.9
260.0	245.3	404.42	v hg	2.582 1370.4	2.827 1422.3	3.067 1474.2	3.305 1526.3	3.776 1632.5
280.0	265.3	411.05	v hg	2.392 1369.4	2.621 1421.5	2.845 1473.5	3.066 1525.8	3.504 1632.1
300.0	285.3	417.33	v hg	2.227 1368.3	2.442 1420.6	2.652 1472.8	2.859 1525.2	3.269 1631.7
320.0	305.3	423.29	v hg	2.083 1367.2	2.285 1419.8	2.483 1472.1	2.678 1524.7	3.063 1631.3
340.0	325.3	428.97	v hg	1.9562 1366.1	2.147 1419.0	2.334 1471.5	2.518 1524.1	2.881 1630.9
360.0	345.3	434.40	v hg	1.8431 1365.0	2.025 1418.1	2.202 1470.8	2.376 1523.5	2.719 1630.5

Properties of Superheated Steam continued...

Pressure (lbs. per sq. in.)		Sat. Temp. t	v hg	Total Temperature (t) (°F)					
Absolute P'	Gauge P			500°	540°	600°	640°	660°	700°
380.0	365.3	439.60	v hg	1.3616 1247.7	1.444 1273.1	1.5605 1308.5	1.6345 1331.0	1.6707 1342.0	1.7419 1363.8
400.0	385.3	444.59	v hg	1.2851 1245.1	1.3652 1271.0	1.4770 1306.9	1.5480 1329.6	1.5827 1340.8	1.6508 1362.7
420.0	405.3	449.39	v hg	1.2158 1242.5	1.2935 1268.9	1.4014 1305.3	1.4697 1328.3	1.5030 1339.5	1.5684 1361.6
440.0	425.3	454.02	v hg	1.1526 1239.8	1.2282 1266.7	1.3327 1303.6	1.3984 1326.9	1.4306 1338.2	1.4934 1360.4
460.0	445.3	458.50	v hg	1.0948 1237.0	1.1685 1264.5	1.2698 1302.0	1.3334 1325.4	1.3644 1336.9	1.4250 1359.3
480.0	465.3	462.82	v hg	1.0417 1234.2	1.1138 1262.3	1.2122 1300.3	1.2737 1324.0	1.3038 1335.6	1.3622 1358.2
500.0	485.3	467.01	v hg	0.9927 1231.3	1.0633 1260.0	1.1591 1298.6	1.2188 1322.6	1.2478 1334.2	1.3044 1357.0
520.0	505.3	471.07	v hg	0.9473 1228.3	1.0166 1257.7	1.1101 1296.9	1.1681 1321.1	1.1962 1332.9	1.2511 1355.8
540.0	525.3	475.01	v hg	0.9052 1225.3	0.9733 1255.4	1.0646 1295.2	1.1211 1319.7	1.1485 1331.5	1.2017 1354.6

Pressure (lbs. per sq. in.)		Sat. Temp. t	v hg	Total Temperature (t) (°F)				
Absolute P'	Gauge P			740°	800°	900°	1000°	1200°
380.0	365.3	439.60	v hg	1.8118 1385.3	1.9149 1417.3	2.083 1470.1	2.249 1523.0	2.575 1630.0
400.0	385.3	444.59	v hg	1.7177 1384.3	1.8161 1416.4	1.9767 1469.4	2.134 1522.4	2.445 1629.6
420.0	405.3	449.39	v hg	1.6324 1383.3	1.7267 1415.5	1.8802 1468.7	2.031 1521.9	2.327 1629.2
440.0	425.3	454.02	v hg	1.5549 1382.3	1.6454 1414.7	1.7925 1468.1	1.9368 1521.3	2.220 1628.8
460.0	445.3	458.50	v hg	1.4842 1381.3	1.5711 1413.8	1.7124 1467.4	1.8508 1520.7	2.122 1628.4
480.0	465.3	462.82	v hg	1.4193 1380.3	1.5031 1412.9	1.6390 1466.7	1.7720 1520.2	2.033 1628.0
500.0	485.3	467.01	v hg	1.3596 1379.3	1.4405 1412.1	1.5715 1466.0	1.6996 1519.6	1.9504 1627.6
520.0	505.3	471.07	v hg	1.3045 1378.2	1.3826 1411.2	1.5091 1465.3	1.6326 1519.0	1.8743 1627.2
540.0	525.3	475.01	v hg	1.2535 1377.2	1.3291 1410.3	1.4514 1464.6	1.5707 1518.5	1.8039 1626.8

## Properties of Superheated Steam continued...

Pressure (lbs. per sq. in.)		Sat. Temp. t	v hg	Total Temperature (t) (°F)					
Absolute P'	Gauge P			500°	540°	600°	640°	660°	700°
560.0	545.3	478.85	v hg	0.8659 1222.2	0.9330 1253.0	1.0224 1293.4	1.0775 1318.2	1.1041 1330.2	1.1558 1353.5
580.0	565.3	482.58	v hg	0.8291 1219.0	0.8954 1250.5	0.9830 1291.7	1.0368 1316.7	1.0627 1328.8	1.1331 1352.3
600.0	585.3	486.21	v hg	0.7947 1215.7	0.8602 1248.1	0.9463 1289.9	0.9988 1315.2	1.0241 1327.4	1.0732 1351.1
620.0	605.3	489.75	v hg	0.7624 1212.4	0.8272 1245.5	0.9118 1288.1	0.9633 1313.7	0.9880 1326.0	1.0358 1349.9
640.0	625.3	493.21	v hg	0.7319 1209.0	0.7963 1243.0	0.8795 1286.2	0.9299 1312.2	0.9541 1324.6	1.0008 1348.6
660.0	645.3	496.58	v hg	0.7032 1205.4	0.7670 1240.4	0.8491 1284.4	0.8985 1310.6	0.9222 1323.2	0.9679 1347.4
680.0	665.3	499.88	v hg	0.6759 1201.8	0.7395 1237.7	0.8205 1282.5	0.8690 1309.1	0.8922 1321.7	0.9369 1346.2
700.0	685.3	503.10	v hg	--- ---	0.7134 1235.0	0.7934 1280.6	0.8411 1307.5	0.8639 1320.3	0.9077 1345.0
750.0	735.3	510.86	v hg	--- ---	0.6540 1227.9	0.7319 1275.7	0.7778 1303.5	0.7996 1316.6	0.8414 1341.8

Pressure (lbs. per sq. in.)		Sat. Temp. t	v hg	Total Temperature (t) (°F)				
Absolute P'	Gauge P			740°	800°	900°	1000°	1200°
560.0	545.3	478.85	v hg	1.2060 1376.1	1.2794 1409.4	1.3978 1463.9	1.5132 1517.9	1.7385 1626.4
580.0	565.3	482.58	v hg	1.1619 1375.1	1.2331 1408.6	1.3479 1463.2	1.4596 1517.3	1.6776 1626.0
600.0	585.3	486.21	v hg	1.1207 1374.0	1.1899 1407.7	1.3013 1462.5	1.4096 1516.7	1.6208 1625.5
620.0	605.3	489.75	v hg	1.0821 1373.0	1.1494 1406.8	1.2577 1461.8	1.3628 1516.2	1.5676 1625.1
640.0	625.3	493.21	v hg	1.0459 1371.9	1.1115 1405.9	1.2168 1461.1	1.3190 1515.6	1.5178 1624.7
660.0	645.3	496.58	v hg	1.0119 1370.8	1.0759 1405.0	1.1784 1460.4	1.2778 1515.0	1.4709 1624.3
680.0	665.3	499.88	v hg	0.9800 1369.8	1.0424 1404.1	1.1423 1459.7	1.2390 1514.5	1.4269 1623.9
700.0	685.3	503.10	v hg	0.9498 1368.7	1.0108 1403.2	1.1082 1459.0	1.2024 1513.9	1.3853 1623.5
750.0	735.3	510.86	v hg	0.8813 1366.0	0.9391 1400.9	1.0310 1457.2	1.1196 1512.4	1.2912 1622.4

## Properties of Superheated Steam continued...

Pressure (lbs. per sq. in.)		Sat. Temp. t	v hg	Total Temperature (t) (°F)					
Absolute p'	Gauge P			500°	540°	600°	640°	660°	700°
800.0	785.3	518.23	v hg	--- ---	0.6015 1220.5	0.6779 1270.7	0.7223 1299.4	0.7433 1312.9	0.7833 1338.6
850.0	835.3	525.26	v hg	--- ---	0.5546 1212.7	0.6301 1265.5	0.6732 1295.2	0.6934 1309.0	0.7320 1335.4
900.0	885.3	531.98	v hg	--- ---	0.5124 1204.4	0.5873 1260.1	0.6294 1290.9	0.6491 1305.1	0.6863 1332.1
950.0	935.3	538.42	v hg	--- ---	0.4740 1195.5	0.5489 1254.6	0.5901 1286.4	0.6092 1301.1	0.6453 1328.7
1000.0	985.3	544.61	v hg	--- ---	--- ---	0.5140 1248.8	0.5546 1281.9	0.5733 1297.0	0.6084 1325.3

Pressure (lbs. per sq. in.)		Sat. Temp. t	v hg	Total Temperature (t) (°F)				
Absolute p'	Gauge P			740°	800°	900°	1000°	1200°
800.0	785.3	518.23	v hg	0.8215 1363.2	0.8763 1398.6	0.9633 1455.4	1.0470 1511.0	1.2088 1621.4
850.0	835.3	525.26	v hg	0.7685 1360.4	0.8209 1396.3	0.9037 1453.6	0.9830 1509.5	1.1360 1620.4
900.0	885.3	531.98	v hg	0.7215 1357.5	0.7716 1393.9	0.8506 1451.8	0.9262 1508.1	1.0714 1619.3
950.0	935.3	538.42	v hg	0.6793 1354.7	0.7275 1391.6	0.8031 1450.0	0.8753 1506.6	1.0136 1618.3
1000.0	985.3	544.61	v hg	0.6413 1351.7	0.6878 1389.2	0.7604 1448.2	0.8294 1505.1	0.9615 1617.3

## Properties of Superheated Steam continued...

Pressure (lbs. per sq. in.)		Sat. Temp. t	v hg	Total Temperature (t) (°F)					
Absolute P'	Gauge P			660°	700°	740°	760°	780°	800°
1100.0	1085.3	556.31	v hg	0.5110 1288.5	0.5445 1318.3	0.5755 1345.8	0.5904 1358.9	0.6049 1371.7	0.6191 1384.3
1200.0	1185.3	567.22	v hg	0.4586 1279.6	0.4909 1311.0	0.5206 1339.6	0.5347 1353.2	0.5484 1366.4	0.5617 1379.3
1300.0	1285.3	577.46	v hg	0.4139 1270.2	0.4454 1303.4	0.4739 1333.3	0.4874 1347.3	0.5004 1361.0	0.5131 1374.3
1400.0	1385.3	587.10	v hg	0.3753 1260.3	0.4062 1295.5	0.4338 1326.7	0.4468 1341.3	0.4593 1355.4	0.4714 1369.1
1500.0	1485.3	596.23	v hg	0.3413 1249.8	0.3719 1287.2	0.3989 1320.0	0.4114 1335.2	0.4235 1349.7	0.4352 1363.8
1600.0	1585.3	604.90	v hg	0.3112 1238.7	0.3417 1278.7	0.3682 1313.0	0.3804 1328.8	0.3921 1343.9	0.4034 1358.4
1700.0	1685.3	613.15	v hg	0.2842 1226.8	0.3148 1269.7	0.3410 1305.8	0.3529 1322.3	0.3643 1337.9	0.3753 1352.9
1800.0	1785.3	621.03	v hg	0.2597 1214.0	0.2907 1260.3	0.3166 1298.4	0.3284 1315.5	0.3395 1331.8	0.3502 1347.2
1900.0	1885.3	628.58	v hg	0.2371 1200.2	0.2688 1250.4	0.2947 1290.6	0.3063 1308.6	0.3173 1325.4	0.3277 1341.5

Pressure (lbs. per sq. in.)		Sat. Temp. t	v hg	Total Temperature (t) (°F)				
Absolute P'	Gauge P			860°	900°	1000°	1100°	1200°
1100.0	1085.3	556.31	v hg	0.6601 1420.8	0.6866 1444.5	0.7503 1502.2	0.8177 1558.8	0.8716 1615.2
1200.0	1185.3	567.22	v hg	0.6003 1416.7	0.6250 1440.7	0.6843 1499.2	0.7412 1556.4	0.7967 1613.1
1300.0	1285.3	577.46	v hg	0.5496 1412.5	0.5728 1437.0	0.6284 1496.2	0.6816 1553.9	0.7333 1611.0
1400.0	1385.3	587.10	v hg	0.5061 1408.2	0.5281 1433.1	0.5805 1493.2	0.6305 1551.4	0.6789 1608.9
1500.0	1485.3	596.23	v hg	0.4684 1403.9	0.4893 1429.3	0.5390 1490.1	0.5862 1548.9	0.6318 1606.8
1600.0	1585.3	604.90	v hg	0.4353 1399.5	0.4553 1425.3	0.5027 1487.0	0.5474 1546.4	0.5906 1604.6
1700.0	1685.3	613.15	v hg	0.4061 1395.0	0.4253 1421.4	0.4706 1484.0	0.5132 1543.8	0.5542 1602.5
1800.0	1785.3	621.03	v hg	0.3801 1390.4	0.3986 1417.4	0.4421 1480.8	0.4828 1541.3	0.5218 1600.4
1900.0	1885.3	628.58	v hg	0.3568 1385.8	0.3747 1413.3	0.4165 1477.7	0.4556 1538.8	0.4929 1598.2

## Properties of Superheated Steam continued...

Pressure (lbs. per sq. in.)		Sat. Temp. t	v hg	Total Temperature (t) (°F)					
Absolute P'	Gauge P			660°	700°	740°	760°	780°	800°
2000.0	1985.3	635.82	v hg	0.2161 1184.9	0.2489 1240.0	0.2748 1282.6	0.2863 1301.4	0.2972 1319.0	0.3074 1335.5
2100.0	2085.3	642.77	v hg	0.1962 1167.7	0.2306 1229.0	0.2567 1274.3	0.2682 1294.0	0.2789 1312.3	0.2890 1329.5
2200.0	2185.3	649.46	v hg	0.1768 1147.8	0.2135 1217.4	0.2400 1265.7	0.2514 1286.3	0.2621 1305.4	0.2721 1323.3
2300.0	2285.3	655.91	v hg	0.1575 1123.8	0.1978 1204.9	0.2247 1256.7	0.2362 1278.4	0.2468 1298.4	0.2567 1316.9
2400.0	2385.3	662.12	v hg	---	0.1828 1191.5	0.2105 1247.3	0.2221 1270.2	0.2327 1291.1	0.2425 1310.3
2500.0	2485.3	668.13	v hg	---	0.1686 1176.8	0.1973 1237.6	0.2090 1261.8	0.2196 1283.6	0.2294 1303.6
2600.0	2585.3	673.94	v hg	---	0.1549 1160.6	0.1849 1227.3	0.1967 1252.9	0.2074 1275.8	0.2172 1296.8
2700.0	2685.3	679.55	v hg	---	0.1415 1142.5	0.1732 1216.5	0.1853 1243.8	0.1960 1267.9	0.2059 1289.7
2800.0	2785.3	684.99	v hg	---	0.1281 1121.4	0.1622 1205.1	0.1745 1234.2	0.1854 1259.6	0.1953 1282.4

Pressure (lbs. per sq. in.)		Sat. Temp. t	v hg	Total Temperature (t) (°F)				
Absolute P'	Gauge P			860°	900°	1000°	1100°	1200°
2000.0	1985.3	635.82	v hg	0.3358 1381.2	0.3532 1409.2	0.3935 1474.5	0.4311 1536.2	0.4668 1596.1
2100.0	2085.3	642.77	v hg	0.3167 1376.4	0.3337 1405.0	0.3727 1471.4	0.4089 1533.6	0.4433 1593.9
2200.0	2185.3	649.46	v hg	0.2994 1371.5	0.3159 1400.8	0.3538 1468.2	0.3837 1531.1	0.4218 1591.8
2300.0	2285.3	655.91	v hg	0.2835 1366.6	0.2997 1396.5	0.3365 1464.9	0.3703 1528.5	0.4023 1589.6
2400.0	2385.3	662.12	v hg	0.2689 1361.6	0.2848 1392.2	0.3207 1461.7	0.3534 1525.9	0.3843 1587.4
2500.0	2485.3	668.13	v hg	0.2555 1356.5	0.2710 1387.8	0.3061 1458.4	0.3379 1523.2	0.3678 1585.3
2600.0	2585.3	673.94	v hg	0.2431 1351.4	0.2584 1383.4	0.2926 1455.1	0.3236 1520.6	0.3526 1583.1
2700.0	2685.3	679.55	v hg	0.2315 1346.1	0.2466 1378.9	0.2801 1451.8	0.3103 1518.0	0.3385 1580.9
2800.0	2785.3	684.99	v hg	0.2208 1340.8	0.2356 1374.3	0.2685 1448.5	0.2979 1515.4	0.3254 1578.7



## Properties of Superheated Steam continued...

Pressure (lbs. per sq. in.)		Sat. Temp. t	v hg	Total Temperature (t) (°F)					
Absolute P'	Gauge P			660°	700°	740°	760°	780°	800°
2900.0	2885.3	690.26	v hg	--- ---	0.1143 1095.9	0.1517 1193.0	0.1644 1224.3	0.1754 1251.1	0.1853 1274.9
3000.0	2985.3	695.36	v hg	--- ---	0.0984 1060.7	0.1416 1180.1	0.1548 1213.8	0.1660 1242.2	0.1760 1267.2
3100.0	3085.3	700.31	v hg	--- ---	--- ---	0.1320 1166.2	0.1456 1202.9	0.1571 1233.0	0.1672 1259.3
3200.0	3185.3	705.11	v hg	--- ---	--- ---	0.1226 1151.1	0.1369 1191.4	0.1486 1223.5	0.1589 1251.1
3206.2	3191.5	705.40	v hg	--- ---	--- ---	0.1220 1150.2	0.1363 1190.6	0.1480 1222.9	0.1583 1250.5

Pressure (lbs. per sq. in.)		Sat. Temp. t	v hg	Total Temperature (t) (°F)				
Absolute P'	Gauge P			860°	900°	1000°	1100°	1200°
2900.0	2885.3	690.26	v hg	0.2108 1335.3	0.2254 1369.7	0.2577 1445.1	0.2864 1512.7	0.3132 1576.5
3000.0	2985.3	695.36	v hg	0.2014 1329.7	0.2159 1365.0	0.2476 1441.8	0.2757 1510.0	0.3018 1574.3
3100.0	3085.3	700.31	v hg	0.1926 1324.1	0.2070 1360.3	0.2382 1438.4	0.2657 1507.4	0.2911 1572.1
3200.0	3185.3	705.11	v hg	0.1843 1318.3	0.1986 1355.5	0.2293 1434.9	0.2563 1504.7	0.2811 1569.9
3206.2	3191.5	705.40	v hg	0.1838 1317.9	0.1981 1355.2	0.2288 1434.7	0.2557 1504.5	0.2806 1569.8

# Chapter 14

## Pipe Data



## 14.1 Pipe Engagement

Length of thread on pipe to make a tight joint:

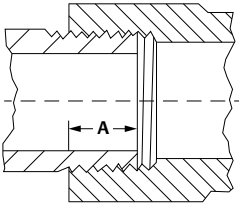
	Nominal Pipe Size (Inches)	Dimension A (Inches)	Nominal Pipe Size (Inches)	Dimension A (Inches)
	1/8	0.27	1-1/2	0.68
	1/4	0.39	2	0.70
	3/8	0.41	2-1/2	0.93
	1/2	0.53	3	1.02
	3/4	0.55	4	1.09
	1	0.66	5	1.19
	1-1/4	0.68	6	1.21
<p><i>Dimension A is the sum of L1 (handtight engagement) and L3 (wrench makeup length for internal thread) from ASME B1.20.1-1992.</i></p>				

## 14.2 Carbon and Alloy Steel - Stainless Steel

Identification, wall thickness, and weights are extracted from ASME B36.10M and B36.19M. The notations STD, XS, and XXS indicate Standard, Extra Strong, and Double Extra Strong pipe, respectively.

Transverse internal area values listed in “sq. ft.” also represent volume in cubic feet per foot of pipe length.

Nominal Pipe Size (NPS) (in.)	Nominal Diameter (DN)	Outside Diameter (in.)	Identification			Wall Thickness (t) (in.)	Inside Diameter (d) (in.)	Area of Metal (sq. in.)	Transverse Internal Area		Weight Pipe (Lb./ft.)	Water Weight (Lb./ft. Pipe)
			Steel		Stainless Steel Sched. No.				(a) (Sq. in.)	(A) (Sq. ft.)		
			Iron Pipe Size	Sched. No.								
1/8	6	0.405	--	---	105	0.049	0.307	0.0548	0.0740	0.00051	0.19	0.032
			--	30	--	0.057	0.291	0.0623	0.0665	0.00046	0.21	0.029
			STD	40	405	0.068	0.269	0.0720	0.0568	0.00039	0.24	0.025
			XS	80	805	0.095	0.215	0.0925	0.0363	0.00025	0.31	0.016
1/4	8	0.540	--	---	105	0.065	0.410	0.0970	0.1320	0.00092	0.33	0.057
			--	30	--	0.073	0.394	0.1071	0.1219	0.00085	0.36	0.053
			STD	40	405	0.088	0.364	0.1250	0.1041	0.00072	0.42	0.045
			XS	80	805	0.119	0.302	0.1574	0.0716	0.00050	0.54	0.031
3/8	10	0.675	---	---	105	0.065	0.545	0.1246	0.2333	0.00162	0.42	0.101
			---	30	--	0.073	0.529	0.1381	0.2198	0.00153	0.47	0.095
			STD	40	405	0.091	0.493	0.1670	0.1909	0.00133	0.57	0.083
			XS	80	805	0.126	0.423	0.2173	0.1405	0.00098	0.74	0.061

## Carbon and Alloy Steel - Stainless Steel continued...

Nominal Pipe Size (NPS) (in.)	Nominal Diameter (DN)	Outside Diameter (in.)	Identification				Wall Thickness (t) (in.)	Inside Diameter (d) (in.)	Area of Metal (sq. in.)	Transverse Internal Area		Weight Pipe (Lb./ft.)	Water Weight (Lb./ft. Pipe)
			Steel		Stainless Steel Sched. No.	(a) (Sq. in.)				(A) (Sq. ft.)			
			Iron Pipe Size	Sched. No.									
1/2	15	0.840	---	---	5S	0.065	0.710	0.1583	0.3959	0.00275	0.54	0.172	
			---	---	10S	0.083	0.674	0.1974	0.3568	0.00248	0.67	0.155	
			---	30	---	0.095	0.650	0.2223	0.3318	0.00230	0.76	0.144	
			STD	40	40S	0.109	0.622	0.2503	0.3039	0.00211	0.85	0.132	
			XS	80	80S	0.147	0.546	0.3200	0.2341	0.00163	1.09	0.101	
			---	160	---	0.188	0.464	0.3851	0.1691	0.00117	1.31	0.073	
			XXS	---	---	0.294	0.252	0.5043	0.0499	0.00035	1.71	0.022	
3/4	20	1.050	---	---	5S	0.065	0.920	0.2011	0.6648	0.00462	0.69	0.288	
			---	---	10S	0.083	0.884	0.2521	0.6138	0.00426	0.86	0.266	
			---	30	---	0.095	0.860	0.2850	0.5809	0.00403	0.97	0.252	
			STD	40	40S	0.113	0.824	0.3326	0.5333	0.00370	1.13	0.231	
			XS	80	80S	0.154	0.742	0.4335	0.4324	0.00300	1.47	0.187	
			---	160	---	0.219	0.612	0.5717	0.2942	0.00204	1.94	0.127	
			XXS	---	---	0.308	0.434	0.7180	0.1479	0.00103	2.44	0.064	
1	25	1.315	---	---	5S	0.065	1.185	0.2553	1.103	0.00766	0.87	0.478	
			---	---	10S	0.109	1.097	0.4130	0.9452	0.00656	1.40	0.410	
			---	30	---	0.114	1.087	0.4301	0.9280	0.00644	1.46	0.402	
			STD	40	40S	0.133	1.049	0.4939	0.8643	0.00600	1.68	0.375	
			XS	80	80S	0.179	0.957	0.6388	0.7193	0.00500	2.17	0.312	
			---	160	---	0.250	0.815	0.8365	0.5217	0.00362	2.84	0.226	
			XXS	---	---	0.358	0.599	1.0763	0.2818	0.00196	3.66	0.122	
1-1/4	32	1.660	---	---	5S	0.065	1.530	0.3257	1.839	0.01277	1.11	0.797	
			---	---	10S	0.109	1.442	0.5311	1.633	0.01134	1.81	0.708	
			---	30	---	0.117	1.426	0.5672	1.597	0.01109	1.93	0.692	
			STD	40	40S	0.140	1.380	0.6685	1.496	0.01039	2.27	0.648	
			XS	80	80S	0.191	1.278	0.8815	1.283	0.00891	3.00	0.556	
			---	160	---	0.250	1.160	1.1070	1.057	0.00734	3.76	0.458	
			XXS	---	---	0.382	0.896	1.5340	0.6305	0.00438	5.21	0.273	

## Carbon and Alloy Steel - Stainless Steel continued...

Nominal Pipe Size (NPS) (in.)	Nominal Diameter (DN)	Outside Diameter (in.)	Identification				Wall Thickness (t) (in.)	Inside Diameter (d) (in.)	Area of Metal (sq. in.)	Transverse Internal Area		Weight Pipe (Lb./ft.)	Water Weight (Lb./ft. Pipe)
			Steel		Stainless Steel Sched. No.	(a) (Sq. in.)				(A) (Sq. ft.)			
			Iron Pipe Size	Sched. No.									
1-1/2	40	1.900	---	---	5S	0.065	1.770	0.3747	2.461	0.01709	1.28	1.066	
			---	---	10S	0.109	1.682	0.6133	2.222	0.01543	2.09	0.963	
			---	30	---	0.125	1.650	0.6970	2.138	0.01485	2.37	0.927	
			STD	40	40S	0.145	1.610	0.7995	2.036	0.01414	2.72	0.882	
			XS	80	80S	0.200	1.500	1.068	1.767	0.01227	3.63	0.766	
			---	160	---	0.281	1.338	1.429	1.406	0.00976	4.86	0.609	
			XXS	---	---	0.400	1.100	1.885	0.9503	0.00660	6.41	0.412	
2	50	2.375	---	---	5S	0.065	2.245	0.4717	3.958	0.02749	1.61	1.715	
			---	---	10S	0.109	2.157	0.7760	3.654	0.02538	2.64	1.583	
			---	30	---	0.125	2.125	0.8836	3.547	0.02463	3.00	1.537	
			STD	40	40S	0.154	2.067	1.075	3.356	0.02330	3.65	1.454	
			XS	80	80S	0.218	1.939	1.477	2.953	0.02051	5.02	1.280	
			---	160	---	0.344	1.687	2.195	2.235	0.01552	7.46	0.969	
			XXS	---	---	0.436	1.503	2.656	1.774	0.01232	9.03	0.769	
2-1/2	65	2.875	---	---	5S	0.083	2.709	0.7280	5.764	0.04003	2.48	2.498	
			---	---	10S	0.120	2.635	1.039	5.453	0.03787	3.53	2.363	
			---	30	---	0.188	2.499	1.587	4.905	0.03406	5.40	2.125	
			STD	40	40S	0.203	2.469	1.704	4.788	0.03325	5.79	2.075	
			XS	80	80S	0.276	2.323	2.254	4.238	0.02943	7.66	1.837	
			---	160	---	0.375	2.125	2.945	3.547	0.02463	10.01	1.537	
			XXS	---	---	0.552	1.771	4.028	2.463	0.01711	13.69	1.067	
3	80	3.500	---	---	5S	0.083	3.334	0.8910	8.730	0.06063	3.03	3.783	
			---	---	10S	0.120	3.260	1.274	8.347	0.05796	4.33	3.617	
			30	---	---	0.188	3.124	1.956	7.665	0.05323	6.65	3.322	
			STD	40	40S	0.216	3.068	2.228	7.393	0.05134	7.58	3.203	
			XS	80	80S	0.300	2.900	3.016	6.605	0.04587	10.25	2.862	
			---	160	---	0.438	2.624	4.213	5.408	0.03755	14.32	2.343	
			XXS	---	---	0.600	2.300	5.466	4.155	0.02885	18.58	1.800	
3-1/2	90	4.000	---	---	5S	0.083	3.834	1.021	11.55	0.08017	3.48	5.003	
			---	---	10S	0.120	3.760	1.463	11.10	0.07711	4.97	4.812	
			30	---	---	0.188	3.624	2.251	10.31	0.07163	7.65	4.470	
			STD	40	40S	0.226	3.548	2.680	9.887	0.06866	9.11	4.284	
			XS	80	80S	0.318	3.364	3.678	8.888	0.06172	12.50	3.851	

Carbon and Alloy Steel - Stainless Steel continued...

Nominal Pipe Size (NPS) (in.)	Nominal Diameter (DN)	Outside Diameter (in.)	Identification			Wall Thickness (t) (in.)	Inside Diameter (d) (in.)	Area of Metal (sq.in.)	Transverse Internal Area		Weight Pipe (Lb./ft. Pipe)	Water Weight (Lb./ft. Pipe)
			Steel						(a) (Sq. in.)	(A) (Sq. ft.)		
			Iron Pipe Size	Sched. No.	Stainless Steel Sched. No.							
4	100	4.500	---	---	5S	0.083	4.334	1.152	14.75	0.10245	3.92	6.393
			---	---	10S	0.120	4.260	1.651	14.25	0.09898	5.61	6.176
			---	30	---	0.188	4.124	2.547	13.36	0.09276	8.66	5.788
			STD	40	40S	0.237	4.026	3.174	12.73	0.08840	10.79	5.516
			XS	80	80S	0.337	3.826	4.407	11.50	0.07984	14.98	4.982
			---	120	---	0.438	3.624	5.589	10.31	0.07163	19.00	4.470
			---	160	---	0.531	3.438	6.621	9.283	0.06447	22.51	4.023
---	XXS	---	0.674	3.152	8.101	7.803	0.05419	27.54	3.381			
5	125	5.563	---	---	5S	0.109	5.345	1.868	22.44	0.15582	6.36	9.723
			---	---	10S	0.134	5.295	2.285	22.02	0.15292	7.77	9.542
			STD	40	40S	0.258	5.047	4.300	20.01	0.13893	14.62	8.669
			XS	80	80S	0.375	4.813	6.112	18.19	0.12635	20.78	7.884
			---	120	---	0.500	4.563	7.953	16.35	0.11356	27.04	7.086
			---	160	---	0.625	4.313	9.696	14.61	0.10146	32.96	6.331
			XXS	---	---	0.750	4.063	11.34	12.97	0.09004	38.55	5.618
6	150	6.625	---	---	5S	0.109	6.407	2.231	32.24	0.22389	7.60	13.97
			---	---	10S	0.134	6.357	2.733	31.74	0.22041	9.29	13.75
			STD	40	40S	0.28	6.065	5.581	28.89	0.20063	18.97	12.52
			XS	80	80S	0.432	5.761	8.405	26.07	0.18102	28.57	11.30
			---	120	---	0.562	5.501	10.70	23.77	0.16505	36.39	10.30
			---	160	---	0.719	5.187	13.34	21.13	0.14674	45.35	9.157
			XXS	---	---	0.864	4.897	15.64	18.83	0.13079	53.16	8.162
8	200	8.625	---	---	5S	0.109	8.407	2.916	55.51	0.38549	9.93	24.05
			---	---	10S	0.148	8.329	3.941	54.48	0.37837	13.40	23.61
			---	20	---	0.25	8.125	6.578	51.85	0.36006	22.36	22.47
			---	30	---	0.277	8.071	7.265	51.16	0.35529	24.70	22.17
			STD	40	40S	0.322	7.981	8.399	50.03	0.34741	28.55	21.68
			---	60	---	0.406	7.813	10.48	47.94	0.33294	35.64	20.78
			XS	80	80S	0.5	7.625	12.76	45.66	0.31711	43.39	19.79
			---	100	---	0.594	7.437	14.99	43.44	0.30166	50.95	18.82
			---	120	---	0.719	7.187	17.86	40.57	0.28172	60.71	17.58
			---	140	---	0.812	7.001	19.93	38.50	0.26733	67.76	16.68
			XXS	---	---	0.875	6.875	21.30	37.12	0.25779	72.42	16.09
			---	160	---	0.906	6.813	21.97	36.46	0.25317	74.69	15.80

## Carbon and Alloy Steel - Stainless Steel continued...

Nominal Pipe Size (NPS) (in.)	Nominal Diameter (DN)	Outside Diameter (in.)	Identification			Wall Thickness (t) (in.)	Inside Diameter (d) (in.)	Area of Metal (sq. in.)	Transverse Internal Area		Weight Pipe (Lb./ft.)	Water Weight (Lb./ft. Pipe)
			Steel						(a) (Sq. in.)	(A) (Sq. ft.)		
			Iron Pipe Size	Sched. No.	Stainless Steel Sched. No.							
10	250	10.750	---	---	5S	0.134	10.482	4.469	86.29	0.59926	15.19	37.39
			---	---	10S	0.165	10.420	5.487	85.28	0.59219	18.65	36.95
			---	20	---	0.250	10.250	8.247	82.52	0.57303	28.04	35.76
			---	30	---	0.307	10.136	10.07	80.69	0.56035	34.24	34.97
			STD	40	40S	0.365	10.020	11.91	78.85	0.54760	40.48	34.17
			XS	60	80S	0.500	9.750	16.10	74.66	0.51849	54.74	32.35
			---	80	---	0.594	9.562	18.95	71.81	0.49868	64.43	31.12
			---	100	---	0.719	9.312	22.66	68.10	0.47295	77.03	29.51
			---	120	---	0.844	9.062	26.27	64.50	0.44790	89.29	27.95
			XXS	140	---	1.000	8.750	30.63	60.13	0.41758	104.13	26.06
			---	160	---	1.125	8.500	34.02	56.75	0.39406	115.64	24.59
12	300	12.750	---	---	5S	0.156	12.438	6.172	121.5	0.84378	20.98	52.65
			---	---	10S	0.180	12.390	7.108	120.6	0.83728	24.17	52.25
			---	20	---	0.250	12.250	9.818	117.9	0.81847	33.38	51.07
			---	30	---	0.330	12.090	12.88	114.8	0.79723	43.77	49.75
			STD	---	40S	0.375	12.000	14.58	113.1	0.78540	49.56	49.01
			---	40	---	0.406	11.938	15.74	111.9	0.77731	53.52	48.50
			XS	---	80S	0.500	11.750	19.24	108.4	0.75302	65.42	46.99
			---	60	---	0.562	11.626	21.52	106.2	0.73721	73.15	46.00
			---	80	---	0.688	11.374	26.07	101.6	0.70559	88.63	44.03
			---	100	---	0.844	11.062	31.57	96.11	0.66741	107.32	41.65
			XXS	120	---	1.000	10.750	36.91	90.76	0.63030	125.49	39.33
			---	140	---	1.125	10.500	41.09	86.59	0.60132	139.67	37.52
			---	160	---	1.312	10.126	47.14	80.53	0.55925	160.27	34.90

Carbon and Alloy Steel - Stainless Steel continued...

Nominal Pipe Size (NPS) (in.)	Nominal Diameter (DN)	Outside Diameter (in.)	Identification			Wall Thickness (t) (in.)	Inside Diameter (d) (in.)	Area of Metal (sq. in.)	Transverse Internal Area		Weight Pipe (Lb./ft.)	Water Weight (Lb./ft. Pipe)
			Steel						(a) (Sq. in.)	(A) (Sq. ft.)		
			Iron Pipe Size	Sched. No.	Stainless Steel Sched. No.							
14	350	14.000	---	---	5S	0.156	13.688	6.785	147.2	1.02190	23.07	63.77
			---	---	10S	0.188	13.624	8.158	145.8	1.01237	27.73	63.17
			---	10	---	0.250	13.500	10.80	143.1	0.99402	36.71	62.03
			---	20	---	0.312	13.376	13.42	140.5	0.97585	45.61	60.89
			STD	30	---	0.375	13.250	16.05	137.9	0.95755	54.57	59.75
			---	40	---	0.438	13.124	18.66	135.3	0.93942	63.44	58.62
			XS	---	---	0.500	13.000	21.21	132.7	0.92175	72.09	57.52
			---	60	---	0.594	12.812	25.02	128.9	0.89529	85.05	55.87
			---	80	---	0.750	12.500	31.22	122.7	0.85221	106.13	53.18
			---	100	---	0.938	12.124	38.49	115.4	0.80172	130.85	50.03
			---	120	---	1.094	11.812	44.36	109.6	0.76098	150.79	47.49
			---	140	---	1.250	11.500	50.07	103.9	0.72131	170.21	45.01
			---	160	---	1.406	11.188	55.63	98.31	0.68271	189.11	42.60
16	400	16.000	---	---	5S	0.165	15.670	8.208	192.9	1.33926	27.90	83.57
			---	---	10S	0.188	15.624	9.339	191.7	1.33141	31.75	83.08
			---	10	---	0.250	15.500	12.37	188.7	1.31036	42.05	81.77
			---	20	---	0.312	15.376	15.38	185.7	1.28948	52.27	80.46
			STD	30	---	0.375	15.250	18.41	182.7	1.26843	62.58	79.15
			XS	40	---	0.500	15.000	24.35	176.7	1.22719	82.77	76.58
			---	60	---	0.656	14.688	31.62	169.4	1.17667	107.50	73.42
			---	80	---	0.844	14.312	40.19	160.9	1.11720	136.61	69.71
			---	100	---	1.031	13.938	48.48	152.6	1.05957	164.82	66.12
			---	120	---	1.219	13.562	56.61	144.5	1.00317	192.43	62.60
			---	140	---	1.438	13.124	65.79	135.3	0.93942	223.64	58.62
			---	160	---	1.594	12.812	72.14	128.9	0.89529	245.25	55.87



## Carbon and Alloy Steel - Stainless Steel continued...

Nominal Pipe Size (NPS) (in.)	Nominal Diameter (DN)	Outside Diameter (in.)	Identification			Wall Thickness (t) (in.)	Inside Diameter (d) (in.)	Area of Metal (sq. in.)	Transverse Internal Area		Weight Pipe (Lb./ft.)	Water Weight (Lb./ft. Pipe)
			Steel						(a) (Sq. in.)	(A) (Sq. ft.)		
			Iron Pipe Size	Sched. No.	Stainless Steel Sched. No.							
18	450	18.000	---	---	5S	0.165	17.670	9.245	245.2	1.70295	31.43	106.3
			---	---	10S	0.188	17.624	10.52	243.9	1.69409	35.76	105.7
			---	10	---	0.250	17.500	13.94	240.5	1.67034	47.39	104.2
			---	20	---	0.312	17.376	17.34	237.1	1.64675	58.94	102.8
			STD	---	---	0.375	17.250	20.76	233.7	1.62296	70.59	101.3
			---	30	---	0.438	17.124	24.17	230.3	1.59933	82.15	99.80
			XS	---	---	0.500	17.000	27.49	227.0	1.57625	93.45	98.36
			---	40	---	0.562	16.876	30.79	223.7	1.55334	104.67	96.93
			---	60	---	0.750	16.500	40.64	213.8	1.48490	138.17	92.66
			---	80	---	0.938	16.124	50.28	204.2	1.41799	170.92	88.48
			---	100	---	1.156	15.688	61.17	193.3	1.34234	207.96	83.76
			---	120	---	1.375	15.250	71.82	182.7	1.26843	244.14	79.15
			---	140	---	1.562	14.876	80.66	173.8	1.20698	274.22	75.32
			---	160	---	1.781	14.438	90.75	163.7	1.13695	308.50	70.95
20	500	20.000	---	---	5S	0.188	19.624	11.70	302.5	2.10041	39.78	131.1
			---	---	10S	0.218	19.564	13.55	300.6	2.08758	46.06	130.3
			---	10	---	0.250	19.500	15.51	298.6	2.07395	52.73	129.4
			STD	20	---	0.375	19.250	23.12	291.0	2.02111	78.60	126.1
			XS	30	---	0.500	19.000	30.63	283.5	1.96895	104.13	122.9
			---	40	---	0.594	18.812	36.21	277.9	1.93018	123.11	120.4
			---	60	---	0.812	18.376	48.95	265.2	1.84175	166.40	114.9
			---	80	---	1.031	17.938	61.44	252.7	1.75500	208.87	109.5
			---	100	---	1.281	17.438	75.33	238.8	1.65852	256.10	103.5
			---	120	---	1.500	17.000	87.18	227.0	1.57625	296.37	98.36
			---	140	---	1.750	16.500	100.3	213.8	1.48490	341.09	92.66
			---	160	---	1.969	16.062	111.5	202.6	1.40711	379.17	87.80

## Carbon and Alloy Steel - Stainless Steel continued...

Nominal Pipe Size (NPS) (in.)	Nominal Diameter (DN)	Outside Diameter (in.)	Identification			Wall Thickness (t) (in.)	Inside Diameter (d) (in.)	Area of Metal (sq. in.)	Transverse Internal Area		Weight Pipe (Lb./ft.)	Water Weight (Lb./ft. Pipe)
			Steel						(a) (Sq. in.)	(A) (Sq. ft.)		
			Iron Pipe Size	Sched. No.	Stainless Steel Sched. No.							
22	550	22.000	---	---	5S	0.188	21.624	12.88	367.3	2.55035	43.80	159.1
			---	---	10S	0.218	21.564	14.92	365.2	2.53622	50.71	158.3
			---	10	---	0.250	21.500	17.08	363.1	2.52119	58.07	157.3
			STD	20	---	0.375	21.250	25.48	354.7	2.46290	86.61	153.7
			XS	30	---	0.500	21.000	33.77	346.4	2.40529	114.81	150.1
			---	60	---	0.875	20.250	58.07	322.1	2.23655	197.41	139.6
			---	80	---	1.125	19.750	73.78	306.4	2.12747	250.81	132.8
			---	100	---	1.375	19.250	89.09	291.0	2.02111	302.88	126.1
			---	120	---	1.625	18.750	104.0	276.1	1.91748	353.61	119.7
			---	140	---	1.875	18.250	118.5	261.6	1.81658	403.00	113.4
			---	160	---	2.125	17.750	132.7	247.5	1.71840	451.06	107.2
24	600	24.000	---	---	5S	0.218	23.564	16.29	436.1	3.02849	55.37	189.0
			10	---	10S	0.250	23.500	18.65	433.7	3.01206	63.41	188.0
			STD	20	---	0.375	23.250	27.83	424.6	2.94832	94.62	184.0
			XS	---	---	0.500	23.000	36.91	415.5	2.88525	125.49	180.0
			---	30	---	0.562	22.876	41.38	411.0	2.85423	140.68	178.1
			---	40	---	0.688	22.624	50.39	402.0	2.79169	171.29	174.2
			---	60	---	0.969	22.062	70.11	382.3	2.65472	238.35	165.7
			---	80	---	1.219	21.562	87.24	365.1	2.53575	296.58	158.2
			---	100	---	1.531	20.938	108.1	344.3	2.39111	367.39	149.2
			---	120	---	1.812	20.376	126.3	326.1	2.26447	429.39	141.3
			---	140	---	2.062	19.876	142.1	310.3	2.15470	483.12	134.5
---	160	---	2.344	19.312	159.5	292.9	2.03415	542.13	126.9			
26	650	26.000	---	10	---	0.312	25.376	25.18	505.8	3.51216	85.60	219.2
			STD	---	---	0.375	25.250	30.19	500.7	3.47737	102.63	217.0
			XS	20	---	0.500	25.000	40.06	490.9	3.40885	136.17	212.7
28	700	28.000	---	10	---	0.312	27.376	27.14	588.6	4.08760	92.26	255.1
			STD	---	---	0.375	27.250	32.55	583.2	4.05006	110.64	252.7
			XS	20	---	0.500	27.000	43.20	572.6	3.97609	146.85	248.1
			---	30	---	0.625	26.750	53.75	562.0	3.90280	182.73	243.5

## Carbon and Alloy Steel - Stainless Steel continued...

Nominal Pipe Size (NPS) (in.)	Nominal Diameter (DN)	Outside Diameter (in.)	Identification			Wall Thickness (t) (in.)	Inside Diameter (d) (in.)	Area of Metal (sq. in.)	Transverse Internal Area		Weight Pipe (Lb./ft.)	Water Weight (Lb./ft. Pipe)
			Steel						(a) (Sq. in.)	(A) (Sq. ft.)		
			Iron Pipe Size	Sched. No.	Stainless Steel Sched. No.							
30	750	30.000	---	---	5S	0.250	29.500	23.37	683.5	4.74649	79.43	296.2
			10	---	10S	0.312	29.376	29.10	677.8	4.70667	98.93	293.7
			STD	---	---	0.375	29.250	34.90	672.0	4.66638	118.65	291.2
			XS	20	---	0.500	29.000	46.34	660.5	4.58695	157.53	286.2
			---	30	---	0.625	28.750	57.68	649.2	4.50821	196.08	281.3
32	800	32.000	---	10	---	0.312	31.376	31.06	773.2	5.36937	105.59	335.0
			STD	---	---	0.375	31.250	37.26	767.0	5.32633	126.66	332.4
			XS	20	---	0.500	31.000	49.48	754.8	5.24145	168.21	327.1
			---	30	---	0.625	30.750	61.60	742.6	5.15726	209.43	321.8
			---	40	---	0.688	30.624	67.68	736.6	5.11508	230.08	319.2
34	850	34.000	---	10	---	0.312	33.376	33.02	874.9	6.07571	112.25	379.1
			STD	---	---	0.375	33.250	39.61	868.3	6.02992	134.67	376.3
			XS	20	---	0.500	33.000	52.62	855.3	5.93959	178.89	370.6
			---	30	---	0.625	32.750	65.53	842.4	5.84993	222.78	365.0
			---	40	---	0.688	32.624	72.00	835.9	5.80501	244.77	362.2
36	900	36.000	---	10	---	0.312	35.376	34.98	982.9	6.82568	118.92	425.9
			STD	---	---	0.375	35.250	41.97	975.9	6.77714	142.68	422.9
			XS	20	---	0.500	35.000	55.76	962.1	6.68135	189.57	416.9
			---	30	---	0.625	34.750	69.46	948.4	6.58625	236.13	411.0
			---	40	---	0.750	34.500	83.06	934.8	6.49182	282.35	405.1

## 14.3 American Pipe Flange Dimensions

### 14.3.1 Diameter of Bolt Circles

In inches per ASME B16.1, B16.5, and B16.24

Nominal Pipe Size	Class <sup>(1)</sup> 125 (Cast Iron) <sup>(2)</sup> or Class 150 (Steel)	Class <sup>(3)</sup> 250 (Cast Iron) <sup>(2)</sup> or Class 300 (Steel)	Class 600	Class 900	Class 1500	Class 2500
1	3.12	3.50	3.50	4.00	4.00	4.25
1-1/4	3.50	3.88	3.88	4.38	4.38	5.12
1-1/2	3.88	4.50	4.50	4.88	4.88	5.75
2	4.75	5.00	5.00	6.50	6.50	6.75
2-1/2	5.50	5.88	5.88	7.50	7.50	7.75

## Diameter of Bolt Circle continued...

Nominal Pipe Size	Class <sup>(1)</sup> 125 (Cast Iron) <sup>(2)</sup> or Class 150 (Steel)	Class <sup>(3)</sup> 250 (Cast Iron) <sup>(2)</sup> or Class 300 (Steel)	Class 600	Class 900	Class 1500	Class 2500
4	7.50	7.88	8.50	9.25	9.50	10.75
5	8.50	9.25	10.50	11.00	11.50	12.75
6	9.50	10.62	11.50	12.50	12.50	14.50
8	11.75	13.00	13.75	15.50	15.50	17.25
10	14.25	15.25	17.00	18.50	19.00	21.75
12	17.00	17.75	19.25	21.00	22.50	24.38
14	18.75	20.25	20.75	22.00	25.00	---
16	21.25	22.50	23.75	24.25	27.75	---
18	22.75	24.75	25.75	27.00	30.50	---
20	25.00	27.00	28.50	29.50	32.75	---
24	29.50	32.00	33.00	35.50	39.00	---
30	36.00	39.25	---	---	---	---
36	42.75	46.00	---	---	---	---
42	49.50	52.75	---	---	---	---
48	56.00	60.75	---	---	---	---

1. Nominal pipe sizes 1 through 12 also apply to Class 150 cast copper alloy flanges.  
2. These diameters apply to steel valves for nominal pipe sizes 1 through 24.  
3. Nominal pipe sizes 1 through 8 also apply to Class 300 cast copper alloy flanges.

## 14.3.2 Number of Stud Bolts and Diameter

In Inches per ASME B16.1, B16.5, and B16.24

Nominal Pipe Size	Class <sup>(1)</sup> 125 (Cast Iron) <sup>(2)</sup> or Class 150 (Steel)		Class <sup>(3)</sup> 250 (Cast Iron) <sup>(2)</sup> or Class 300 (Steel)		Class 600		Class 900		Class 1500		Class 2500	
	No.	Dia.	No.	Dia.	No.	Dia.	No.	Dia.	No.	Dia.	No.	Dia.
1	4	0.50	4	0.62	4	0.62	4	0.88	4	0.88	4	0.88
1-1/4	4	0.50	4	0.62	4	0.62	4	0.88	4	0.88	4	1.00
1-1/2	4	0.50	4	0.75	4	0.75	4	1.00	4	1.00	4	1.12
2	4	0.62	8	0.62	8	0.62	8	0.88	8	0.88	8	1.00
2-1/2	4	0.62	8	0.75	8	0.75	8	1.00	8	1.00	8	1.12
3	4	0.62	8	0.75	8	0.75	8	0.88	8	1.12	8	1.25
4	8	0.62	8	0.75	8	0.88	8	1.12	8	1.25	8	1.50
5	8	0.75	8	0.75	8	1.00	8	1.25	8	1.50	8	1.75
6	8	0.75	12	0.75	12	1.00	12	1.12	12	1.38	8	2.00
8	8	0.75	12	0.88	12	1.12	12	1.38	12	1.62	12	2.00

Number of Stud Bolts and Diameter continued...

Nominal Pipe Size	Class <sup>(1)</sup> 125 (Cast Iron) <sup>(2)</sup> or Class 150 (Steel)		Class <sup>(3)</sup> 250 (Cast Iron) <sup>(2)</sup> or Class 300 (Steel)		Class 600		Class 900		Class 1500		Class 2500	
	No.	Dia.	No.	Dia.	No.	Dia.	No.	Dia.	No.	Dia.	No.	Dia.
10	12	0.88	16	1.00	16	1.25	16	1.38	12	1.88	12	2.50
12	12	0.88	16	1.12	20	1.25	20	1.38	16	2.00	12	2.75
14	12	1.00	20	1.12	20	1.38	20	1.50	16	2.25	---	---
16	16	1.00	20	1.25	20	1.50	20	1.62	16	2.50	---	---
18	16	1.12	24	1.25	20	1.62	20	1.88	16	2.75	---	---
20	20	1.12	24	1.25	24	1.62	20	2.00	16	3.00	---	---
24	20	1.25	24	1.50	24	1.88	20	2.50	16	3.50	---	---
30	28	1.25	28	1.75	---	---	---	---	---	---	---	---
36	32	1.50	32	2.00	---	---	---	---	---	---	---	---
42	36	1.50	36	2.00	---	---	---	---	---	---	---	---
48	44	1.50	40	2.00	---	---	---	---	---	---	---	---

1. Nominal pipe sizes 1 through 12 also apply to Class 150 cast copper alloy flanges.  
 2. These diameters apply to steel valves for nominal pipe sizes 1 through 24.  
 3. Nominal pipe sizes 1 through 8 also apply to Class 300 cast copper alloy flanges.

### 14.3.3 Flange Diameter

In Inches per ASME B16.1, B16.5, and B16.24

Nominal Pipe Size	Class <sup>(1)</sup> 125 (Cast Iron) <sup>(2)</sup> or Class 150 (Steel)	Class <sup>(3)</sup> 250 (Cast Iron) <sup>(2)</sup> or Class 300 (Steel)	Class 600	Class 900	Class 1500	Class 2500
1	4.25	4.88	4.88	5.88	5.88	6.25
1-1/4	4.62	5.25	5.25	6.25	6.25	7.25
1-1/2	5.00	6.12	6.12	7.00	7.00	8.00
2	6.00	6.50	6.50	8.50	8.50	9.25
2-1/2	7.00	7.50	7.50	9.62	9.62	10.50
3	7.50	8.25	8.25	9.50	10.50	12.00
4	9.00	10.00	10.75	11.50	12.25	14.00
5	10.00	11.00	13.00	13.75	14.75	16.50
6	11.00	12.50	14.00	15.00	15.50	19.00
8	13.50	15.00	16.50	18.50	19.00	21.75
10	16.00	17.50	20.00	21.50	23.00	26.50
12	19.00	20.50	22.00	24.00	26.50	30.00
14	21.00	23.00	23.75	25.25	29.50	---
16	23.50	25.50	27.00	27.75	32.50	---
18	25.00	28.00	29.25	31.00	36.00	---

Flange Diameter continued...

Nominal Pipe Size	Class <sup>(1)</sup> 125 (Cast Iron) <sup>(2)</sup> or Class 150 (Steel)	Class <sup>(2)</sup> 250 (Cast Iron) <sup>(2)</sup> or Class 300 (Steel)	Class 600	Class 900	Class 1500	Class 2500
20	27.50	30.50	32.00	33.75	38.75	---
24	32.00	36.00	37.00	41.00	46.00	---
30	38.75	43.00	---	---	---	---
36	46.00	50.00	---	---	---	---
42	53.00	57.00	---	---	---	---
48	59.50	65.00	---	---	---	---

1. Nominal pipe sizes 1 through 12 also apply to Class 150 cast copper alloy flanges.  
2. Nominal pipe sizes 1 through 8 also apply to Class 300 cast copper alloy flanges.

### 14.3.4 Flange Thickness for Flange Fittings

In Inches per ASME B16.1, B16.5, and B16.24

Nominal Pipe Size	Class 150 (CI) FF and STL	Class 150 STL	Class 150	Class 250 (CI) and Class 300 STL <sup>(1)</sup>	Class 300 STL	CL 300
	RF <sup>(2)</sup>	RTJ	Cast Copper Alloy	RF	RTJ	Cast Copper Alloy
1	0.50	0.75	0.38	0.62	0.87	0.59
1-1/4	0.56	0.81	0.41	0.69	0.94	0.62
1-1/2	0.62	0.87	0.44	0.75	1.00	0.69
2	0.69	0.94	0.50	0.81	1.12	0.75
2-1/2	0.81	1.06	0.56	0.94	1.25	0.81
3	0.88	1.13	0.62	1.06	1.37	0.91
4	0.88	1.13	0.69	1.19	1.50	1.06
5	0.88	1.13	0.75	1.31	1.62	1.12

Nominal Pipe Size	Class 600		Class 900		Class 1500		Class 2500	
	RF	RTJ	RF	RTJ	RF	RTJ	RF	RTJ
1	0.69	0.94	1.12	1.37	1.12	1.37	1.38	1.63
1-1/4	0.81	1.06	1.12	1.37	1.12	1.37	1.50	1.81
1-1/2	0.88	1.13	1.25	1.50	1.25	1.50	1.75	2.06
2	1.00	1.31	1.50	1.81	1.50	1.81	2.00	2.31
2-1/2	1.12	1.43	1.62	1.93	1.62	1.93	2.25	2.62
3	1.25	1.56	1.50	1.81	1.88	2.43	2.62	3.00
4	1.50	1.81	1.75	2.06	2.12	2.43	3.00	3.44
5	1.75	2.06	2.00	2.31	2.88	3.19	3.62	4.12

## Flange Thickness for Flange Fittings continued...

Nominal Pipe Size	Class 150 (CI) FF and STL	Class 150 STL	Class 150	Class 250 (CI) and Class 300 STL <sup>(1)</sup>	Class 300 STL	CL 300
	RF <sup>(2)</sup>	RTJ	Cast Copper Alloy	RF	RTJ	Cast Copper Alloy
6	0.94	1.19	0.81	1.38	1.69	1.19
8	1.06	1.31	0.94	1.56	1.87	1.38
10	1.12	1.37	1.00	1.81	2.12	---
12	1.19	1.44	1.06	1.94	2.25	---
14	1.31	1.56	---	2.06	2.37	---
16	1.38	1.63	---	2.19	2.50	---
18	1.50	1.75	---	2.31	2.62	---
20	1.62	1.87	---	2.44	2.82	---
24	1.81	2.06	---	2.69	3.13	---

Nominal Pipe Size	Class 600		Class 900		Class 1500		Class 2500	
	RF	RTJ	RF	RTJ	RF	RTJ	RF	RTJ
6	1.88	2.19	2.19	2.50	3.25	3.62	4.25	4.75
8	2.19	2.50	2.50	2.81	3.62	4.06	5.00	5.56
10	2.50	2.81	2.75	3.06	4.25	4.69	6.50	7.19
12	2.62	2.93	3.12	3.43	4.88	5.44	7.25	7.94
14	2.75	3.06	3.38	3.82	5.25	5.88	---	---
16	3.00	3.31	3.50	3.94	5.75	6.44	---	---
18	3.25	3.56	4.00	4.50	6.38	7.07	---	---
20	3.50	3.88	4.25	4.75	7.00	7.69	---	---
24	4.00	4.44	5.50	6.12	8.00	8.81	---	---

1. These dimensions apply to steel valves for nominal pipe sizes 1 through 24.  
2. The flange dimensions illustrated are for regularly furnished 0.06-in. raised face.

## 14.4 Cast Steel Flange Standards

### 14.4.1 Cast Steel Flange Standard for PN 10

DN	Flange			Bolting		
	Outside Diameter	Thickness	Bolt Circle Diameter	Number of Bolts	Threads	Bolt Hole Diameter
10	90	16	60	4	M12	14
15	95	16	65	4	M12	14
20	105	18	75	4	M12	14
25	115	18	85	4	M12	14
32	140	18	100	4	M16	18
40	150	18	110	4	M16	18
50	165	18	125	4	M16	18
65	185	18	145	8	M16	18
80	200	20	160	8	M16	18
100	220	20	180	8	M16	18
125	250	22	210	8	M16	18
150	285	22	240	8	M20	22
200	340	24	295	8	M20	22
250	395	26	350	12	M20	22
300	445	26	400	12	M20	22
350	505	26	460	16	M20	22
400	565	26	515	16	M24	26
450	615	28	565	20	M24	26
500	670	28	620	20	M24	26
600	780	30	725	20	M27	30
700	895	35	840	24	M27	30
800	1015	38	950	24	M30	33
900	1115	38	1050	28	M30	33
1000	1230	44	1160	28	M33	36
1200	1455	55	1380	32	M36	39
1400	1675	65	1590	36	M39	42
1600	1915	75	1820	40	M45	48
1800	2115	85	2020	44	M45	48
2000	2325	90	2230	48	M45	48
2200	2550	100	2440	52	M52	56
2400	2760	110	2650	56	M52	56
2600	2960	110	2850	60	M52	56
2800	3180	124	3070	64	M52	56
3000	3405	132	3290	68	M56	62

*All dimensions in mm.*



### 14.4.2 Cast Steel Flange Standard for PN 16

DN	Flange			Bolting		
	Outside Diameter	Thickness	Bolt Circle Diameter	Number of Bolts	Threads	Bolt Hole Diameter
10	90	16	60	4	M12	14
15	95	16	65	4	M12	14
20	105	18	75	4	M12	14
25	115	18	85	4	M12	14
32	140	18	100	4	M16	18
40	150	18	110	4	M16	18
50	165	18	125	4	M16	18
65	185	18	145	4	M16	18
80	200	20	160	8	M16	18
100	220	20	180	8	M16	18
125	250	22	210	8	M16	18
150	285	22	240	8	M20	22
200	340	24	295	12	M20	22
250	405	26	355	12	M24	26
300	460	28	410	12	M24	26
350	520	30	470	16	M24	26
400	580	32	525	16	M27	30
500	715	36	650	20	M30	33
600	840	40	770	20	M33	36
700	910	40	840	24	M33	36
800	1025	41	950	24	M36	39
900	1125	48	1050	28	M36	39
1000	1255	59	1170	28	M39	42
1200	1485	78	1390	32	M45	48
1400	1685	84	1590	36	M45	48
1600	1930	102	1820	40	M52	56
1800	2130	110	2020	44	M52	56
2000	2345	124	2230	48	M56	62

*All dimensions in mm.*

### 14.4.3 Cast Steel Flange Standard for PN 25

DN	Flange			Bolting		
	Outside Diameter	Thickness	Bolt Circle Diameter	Number of Bolts	Threads	Bolt Hole Diameter
10	90	16	60	4	M12	14
15	95	16	65	4	M12	14
20	105	18	75	4	M12	14
25	115	18	85	4	M12	14
32	140	18	100	4	M16	18
40	150	18	110	4	M16	18
50	165	20	125	4	M16	18
65	185	22	145	8	M16	18
80	200	24	160	8	M16	18
100	235	24	190	8	M20	22
125	270	26	220	8	M24	26
150	300	28	250	8	M24	26
200	360	30	310	12	M24	26
250	425	32	370	12	M27	30
300	485	34	430	16	M27	30
350	555	38	490	16	M30	33
400	620	40	550	16	M33	36
500	730	48	660	20	M33	36
600	845	48	770	20	M36	39
700	960	50	875	24	M39	42
800	1085	53	990	24	M45	48
900	1185	57	1090	28	M45	48
1000	1320	63	1210	28	M52	56
<i>All dimensions in mm.</i>						

### 14.4.4 Cast Steel Flange Standard for PN 40

DN	Flange			Bolting		
	Outside Diameter	Thickness	Bolt Circle Diameter	Number of Bolts	Threads	Bolt Hole Diameter
10	90	16	60	4	M12	14
15	95	16	65	4	M12	14
20	105	18	75	4	M12	14
25	115	18	85	4	M12	14
32	140	18	100	4	M16	18
40	150	18	110	4	M16	18
50	165	20	125	4	M16	18
65	185	22	145	8	M16	18
80	200	24	160	8	M16	18
100	235	24	190	8	M20	22
125	270	26	220	8	M24	26
150	300	28	250	8	M24	26
200	375	34	320	12	M27	30
250	450	38	385	12	M30	33
300	515	42	450	16	M30	33
350	580	46	510	16	M33	36
400	660	50	585	16	M36	39
450	685	57	610	20	M36	39
500	755	57	670	20	M39	42
600	890	72	795	20	M45	48

*All dimensions in mm.*

### 14.4.5 Cast Steel Flange Standard for PN 63

DN	Flange			Bolting		
	Outside Diameter	Thickness	Bolt Circle Diameter	Number of Bolts	Threads	Bolt Hole Diameter
10	100	20	70	4	M12	14
15	105	20	75	4	M12	14
25	140	24	100	4	M16	18
32	155	24	110	4	M20	22
40	170	28	125	4	M20	22
50	180	26	135	4	M20	22
65	205	26	160	8	M20	22
80	215	28	170	8	M20	22
100	250	30	200	8	M24	26
125	295	34	240	8	M27	30
150	345	36	280	8	M30	33
200	415	42	345	12	M33	36
250	470	46	400	12	M33	36
300	530	52	460	16	M33	36
350	600	56	525	16	M36	39
400	670	60	585	16	M39	42

*All dimensions in mm.*

### 14.4.6 Cast Steel Flange Standard for PN 100

DN	Flange			Bolting		
	Outside Diameter	Thickness	Bolt Circle Diameter	Number of Bolts	Threads	Bolt Hole Diameter
10	100	20	70	4	M12	14
15	105	20	75	4	M12	14
25	140	24	100	4	M16	18
32	155	24	110	4	M20	22
40	170	28	125	4	M20	22
50	195	30	145	4	M24	26
65	220	34	170	8	M24	26
80	230	36	180	8	M24	26
100	265	40	210	8	M27	30
125	315	40	250	8	M30	33
150	355	44	290	12	M30	33
200	430	52	360	12	M33	36
250	505	60	430	12	M36	39
300	585	68	500	16	M39	42
350	655	74	560	16	M45	48

*All dimensions in mm.*

### 14.4.7 Cast Steel Flange Standard for PN 160

DN	Flange			Bolting		
	Outside Diameter	Thickness	Bolt Circle Diameter	Number of Bolts	Threads	Bolt Hole Diameter
10	100	20	70	4	M12	14
15	105	20	75	4	M12	14
25	140	24	100	4	M16	18
40	170	28	125	4	M20	22
50	195	30	145	4	M24	26
65	220	34	170	8	M24	26
80	230	36	180	8	M24	26
100	265	40	210	8	M27	30
125	315	44	250	8	M30	33
150	355	50	290	12	M30	33
200	430	60	360	12	M33	36
250	515	68	430	12	M39	42
300	585	78	500	16	M39	42

*All dimensions in mm.*

### 14.4.8 Cast Steel Flange Standard for PN 250

DN	Flange			Bolting		
	Outside Diameter	Thickness	Bolt Circle Diameter	Number of Bolts	Threads	Bolt Hole Diameter
10	125	24	85	4	M16	18
15	130	26	90	4	M16	18
25	150	28	105	4	M20	22
40	185	34	135	4	M24	26
50	200	38	150	8	M24	26
65	230	42	180	8	M24	26
80	255	46	200	8	M27	30
100	300	54	235	8	M30	33
125	340	60	275	12	M30	33
150	390	68	320	12	M33	36
200	485	82	400	12	M39	42
250	585	100	490	16	M45	48
300	690	120	590	16	M48	52

*All dimensions in mm.*

### 14.4.9 Cast Steel Flange Standard for PN 320

DN	Flange			Bolting		
	Outside Diameter	Thickness	Bolt Circle Diameter	Number of Bolts	Threads	Bolt Hole Diameter
10	125	24	85	4	M16	18
15	130	26	90	4	M16	18
25	160	34	115	4	M20	22
40	195	38	145	4	M24	26
50	210	42	160	8	M24	26
65	255	51	200	8	M27	30
80	275	55	220	8	M27	30
100	335	65	265	8	M33	36
125	380	75	310	12	M33	36
150	425	84	350	12	M36	39
200	525	103	440	16	M39	42
250	640	125	540	16	M48	52

*All dimensions in mm.*

### 14.4.10 Cast Steel Flange Standard for PN 400

DN	Flange			Bolting		
	Outside Diameter	Thickness	Bolt Circle Diameter	Number of Bolts	Threads	Bolt Hole Diameter
10	125	28	85	4	M16	18
15	145	30	100	4	M20	22
25	180	38	130	4	M24	26
40	220	48	165	4	M27	30
50	235	52	180	8	M27	30
65	290	64	225	8	M30	33
80	305	68	240	8	M30	33
100	370	80	295	8	M36	39
125	415	92	340	12	M36	39
150	475	105	390	12	M39	42
200	585	130	490	16	M45	48

*All dimensions in mm.*



# Chapter 15

## Conversions and Equivalents





## 15.1 Length Equivalents

<i>Note: Use multiplier at convergence of row and column</i>	Meters	Inches	Feet	Millimeters	Miles	Kilometers
Meters	1	39.37	3.2808	1000	0.0006214	0.001
Inches	0.0254	1	0.0833	25.4	0.0001578	0.0000254
Feet	0.3048	12	1	304.8	0.0001894	0.0003048
Millimeters	0.001	0.03937	0.0032808	1	0.0000006214	0.000001
Miles	1609.35	63,360	5,280	1,609,350	1	1.60935
Killometers	1,000	39,370	3280.83	1,000,000	0.62137	1

*1 meter = 100 centimeters = 1000 millimeters = 0.001 kilometers = 1,000,000 micrometers  
To convert metric units, merely adjust the decimal point: 1 millimeter = 1000 microns = 0.03937 inches = 39.37 mils.*

## 15.2 Whole Inch to Millimeter Equivalents

Inch	0	1	2	3	4	5	6	7	8	9
	Millimeters									
0	0.0	25.4	50.8	76.2	101.6	127.0	152.4	177.8	203.2	228.6
10	254.0	279.4	304.8	330.2	355.6	381.0	406.4	431.8	457.2	482.6
20	508.0	533.4	558.8	584.2	609.6	635.0	660.4	685.8	711.2	736.6
30	762.0	787.4	812.8	838.2	863.6	889.0	914.4	939.8	965.2	990.6
40	1016.0	1041.4	1066.8	1092.2	1117.6	1143.0	1168.4	1193.8	1219.2	1244.6
50	1270.0	1295.4	1320.8	1346.2	1371.6	1397.0	1422.4	1447.8	1473.2	1498.6
60	1524.0	1549.4	1574.8	1600.2	1625.6	1651.0	1676.4	1701.8	1727.2	1752.6
70	1778.0	1803.4	1828.8	1854.2	1879.6	1905.0	1930.4	1955.8	1981.2	2006.6
80	2032.0	2057.4	2082.8	2108.2	2133.6	2159.0	2184.4	2209.8	2235.2	2260.6
90	2286.0	2311.4	2336.8	2362.2	2387.6	2413.0	2438.4	2463.8	2489.2	2514.6
100	2540.0	2565.4	2590.8	2616.2	2641.6	2667.0	2692.4	2717.8	2743.2	2768.6

*Note: All values in this table are exact, based on the relation 1 in = 25.4 mm. By manipulation of the decimal point any decimal value or multiple of an inch may be converted to its exact equivalent in millimeters.*

## 15.3 Fractional Inch to Millimeter Equivalents

Inch	0	1/16	1/8	3/16	1/4	5/16	3/8	7/16
	Millimeters							
0	0.0	1.6	3.2	4.8	6.4	7.9	9.5	11.1
1	25.4	27.0	28.6	30.2	31.8	33.3	34.9	36.5
2	50.8	52.4	54.0	55.6	57.2	58.7	60.3	61.9
3	76.2	77.8	79.4	81.0	82.6	84.1	85.7	87.3
4	101.6	103.2	104.8	106.4	108.0	109.5	111.1	112.7
5	127.0	128.6	130.2	131.8	133.4	134.9	136.5	138.1
6	152.4	154.0	155.6	157.2	158.8	160.3	161.9	163.5
7	177.8	179.4	181.0	182.6	184.2	185.7	187.3	188.9
8	203.2	204.8	206.4	208.0	209.6	211.1	212.7	214.3
9	228.6	230.2	231.8	233.4	235.0	236.5	238.1	239.7
10	254.0	255.6	257.2	258.8	260.4	261.9	263.5	265.1

1 inch = 25.4 Millimeters

Fractional Inch to Millimeter Equivalents continued...

Inch	1/2	9/16	5/8	11/16	3/4	13/16	7/8	15/16
	Millimeters							
0	12.7	14.3	15.9	17.5	19.1	20.6	22.2	23.8
1	38.1	39.7	41.3	42.9	44.5	46.0	47.6	49.2
2	63.5	65.1	66.7	68.3	69.9	71.4	73.0	74.6
3	88.9	90.5	92.1	93.7	95.3	96.8	98.4	100.0
4	114.3	115.9	117.5	119.1	120.7	122.2	123.8	125.4
5	139.7	141.3	142.9	144.5	146.1	147.6	149.2	150.8
6	165.1	166.7	168.3	169.9	171.5	173.0	174.6	176.2
7	190.5	192.1	193.7	195.3	196.9	198.4	200.0	201.6
8	215.9	217.5	219.1	220.7	222.3	223.8	225.4	227.0
9	241.3	242.9	244.5	246.1	247.7	249.2	250.8	252.4
10	266.7	268.3	269.9	271.5	273.1	274.6	276.2	277.8

1 inch = 25.4 Millimeters

## 15.4 Additional Fractional Inch to Millimeter Equivalents

Inches		Millimeters	Inches		Millimeters	Inches		Millimeters
Fractions	Decimals		Fractions	Decimals		Fractions	Decimals	
	.00394	.1		.2	5.08		.44	11.176
	.00787	.2	13/64	.203125	5.1594		.45	11.430
	.01	.254		.21	5.334	29/64	.453125	11.5094
	.01181	.3	7/32	.21875	5.5562		.46	11.684
1/64	.015625	.3969		.22	5.588	15/32	.46875	11.9062
	.01575	.4		.23	5.842		.47	11.938
	.01969	.5	15/64	.234375	5.9531		.47244	12.0
	.02	.508		.23622	6.0		.48	12.192
	.02362	.6		.24	6.096	31/64	.484375	12.3031
	.02756	.7	1/4	.25	6.35		.49	12.446
	.03	.762		.26	6.604	1/2	.50	12.7
1/32	.03125	.7938	17/64	.265625	6.7469		.51	12.954
	.0315	.8		.27	6.858		.51181	13.0
	.03543	.9		.27559	7.0	33/64	.515625	13.0969
	.03937	1.0		.28	7.112		.52	13.208
	.04	1.016	9/32	.28125	7.1438		.53	13.462
3/64	.046875	1.1906		.29	7.366	17/32	.53125	13.4938
	.05	1.27	19/64	.296875	7.5406		.54	13.716
	.06	1.524		.30	7.62	35/64	.546875	13.8906
1/16	.0625	1.5875		.31	7.874		.55	13.970
	.07	1.778	5/16	.3125	7.9375		.55118	14.0
5/64	.078125	1.9844		.31496	8.0		.56	14.224
	.07874	2.0		.32	8.128	9/16	.5625	14.2875
	.08	2.032	21/64	.328125	8.3344		.57	14.478
	.09	2.286		.33	8.382	37/64	.578125	14.6844
3/32	.09375	2.3812		.34	8.636		.58	14.732
	.1	2.54	11/32	.34375	8.7312		.59	14.986
7/64	.109375	2.7781		.35	8.89		.59055	15.0
	.11	2.794		.35433	9.0	19/32	.59375	15.0812
	.11811	3.0	23/64	.359375	9.1281		.60	15.24
	.12	3.048		.36	9.144	39/64	.609375	15.4781
1/8	.125	3.175		.37	9.398		.61	15.494
	.13	3.302	3/8	.375	9.525		.62	15.748
	.14	3.556		.38	9.652	5/8	.625	15.875
9/64	.140625	3.5719		.39	9.906		.62992	16.0

*Additional Fractional Inch to Millimeter Equivalents continued...*

Inches		Millimeters	Inches		Millimeters	Inches		Millimeters
Fractions	Decimals		Fractions	Decimals		Fractions	Decimals	
	.15	3.810	25/64	.390625	9.9219		.63	16.002
5/32	.15625	3.9688		.39370	10.0		.64	16.256
	.15748	4.0		.40	10.16	41/64	.640625	16.2719
	.16	4.064	13/32	.40625	10.3188		.65	16.510
	.17	4.318		.41	10.414	21/32	.65625	16.6688
11/64	.171875	4.3656		.42	10.668		.66	16.764
	.18	4.572	27/64	.421875	10.7156		.66929	17.0
3/16	.1875	4.7625		.43	10.922		.67	17.018
	.19	4.826		.43307	11.0	43/64	.671875	17.0656
	.19685	5.0	7/16	.4375	11.1125		.68	17.272
11/16	.6875	17.4625	51/64	.796875	20.2406		.90551	23.0
	.69	17.526		.80	20.320	29/32	.90625	23.0188
	.70	17.78		.81	20.574		.91	23.114
45/64	.703125	17.8594	13/16	.8125	20.6375		.92	23.368
	.70866	18.0		.82	20.828	59/64	.921875	23.4156
	.71	18.034		.82677	21.0		.93	23.622
23/32	.71875	18.2562	53/64	.828125	21.0344	15/16	.9375	23.8125
	.72	18.288		.83	21.082		.94	23.876
	.73	18.542		.84	21.336		.94488	24.0
47/64	.734375	18.6531	27/32	.84375	21.4312		.95	24.130
	.74	18.796		.85	21.590	61/64	.953125	24.2094
	.74803	19.0	55/64	.859375	21.8281		.96	24.384
3/4	.75	19.050		.86	21.844	31/32	.96875	24.6062
	.76	19.304		.86614	22.0		.97	24.638
49/64	.765625	19.4469		.87	22.098		.98	24.892
	.77	19.558	7/8	.875	22.225		.98425	25.0
	.78	19.812		.88	22.352	63/64	.984375	25.0031
25/32	.78125	19.8438		.89	22.606		.99	25.146
	.78740	20.0	57/64	.890625	22.6219	1	1.00000	25.4000
	.79	20.066		.90	22.860			

*Round off decimal points to provide no more than the desired degree of accuracy.*

## 15.5 Area Equivalents

<i>Note: Use multiplier at convergence of row and column</i>	Square Meters	Square Inches	Square Feet	Square Miles	Square Kilometers
Square Meters	1	1549.99	10.7639	$3.861 \times 10^{-7}$	$1 \times 10^{-6}$
Square Inches	0.0006452	1	$6.944 \times 10^{-3}$	$2.491 \times 10^{-10}$	$6.452 \times 10^{-10}$
Square Feet	0.0929	144	1	$3.587 \times 10^{-8}$	$9.29 \times 10^{-8}$
Square Miles	2,589,999	---	27,878,400	1	2.59
Square Kilometers	1,000,000	---	10,763,867	0.3861	1

*1 square meter = 10,000 square centimeters.  
 1 square millimeter = 0.01 square centimeter = 0.00155 square inches.*

## 15.6 Volume Equivalents

<i>Note: Use multiplier at convergence of row and column</i>	Cubic Decimeters (Liters)	Cubic Inches	Cubic Feet	U.S. Quart	U.S. Gallon	Imperial Gallon	U.S. Barrel (Petroleum)
Cubic Decimeters (Liters)	1	61.0234	0.03531	1.05668	0.264178	0.220083	0.00629
Cubic Inches	0.01639	1	$5.787 \times 10^{-4}$	0.01732	0.004329	0.003606	0.000103
Cubic Feet	28.317	1728	1	29.9221	7.48055	6.22888	0.1781
U.S. Quart	0.94636	57.75	0.03342	1	0.25	0.2082	0.00595
U.S. Gallon	3.78543	231	0.13368	4	1	0.833	0.02381
Imperial Gallon	4.54374	277.274	0.16054	4.80128	1.20032	1	0.02877
U.S. Barrel (Petroleum)	158.98	9702	5.6146	168	42	34.973	1

*1 cubic meter = 1,000,000 cubic centimeters.  
 1 liter = 1000 milliliters = 1000 cubic centimeters.*

## 15.7 Volume Rate Equivalents

<i>Note: Use multiplier at convergence of row and column</i>	Liters Per Minute	Cubic Meters Per Hour	Cubic Feet Per Hour	Liters Per Hour	U.S. Gallon Per Minute	U.S. Barrel Per Day
Liters Per Minute	1	0.06	2.1189	60	0.264178	9.057
Cubic Meters Per Hour	16.667	1	35.314	1000	4.403	151
Cubic Feet Per Hour	0.4719	0.028317	1	28.317	0.1247	4.2746
Liters Per Hour	0.016667	0.001	0.035314	1	0.004403	0.151
U.S. Gallon Per Minute	3.785	0.2273	8.0208	227.3	1	34.28
U.S. Barrel Per Day	0.1104	0.006624	0.23394	6.624	0.02917	1

## 15.8 Mass Conversion—Pounds to Kilograms

Pounds	0	1	2	3	4	5	6	7	8	9
	Kilograms									
0	0.00	0.45	0.91	1.36	1.81	2.27	2.72	3.18	3.63	4.08
10	4.54	4.99	5.44	5.90	6.35	6.80	7.26	7.71	8.16	8.62
20	9.07	9.53	9.98	10.43	10.89	11.34	11.79	12.25	12.70	13.15
30	13.61	14.06	14.52	14.97	15.42	15.88	16.33	16.78	17.24	17.69
40	18.14	18.60	19.05	19.50	19.96	20.41	20.87	21.32	21.77	22.23
50	22.68	23.13	23.59	24.04	24.49	24.95	25.40	25.86	26.31	26.76
60	27.22	27.67	28.12	28.58	29.03	29.48	29.94	30.39	30.84	31.30
70	31.75	32.21	32.66	33.11	33.57	34.02	34.47	34.93	35.38	35.83
80	36.29	36.74	37.20	37.65	38.10	38.56	39.01	39.46	39.92	40.37
90	40.82	41.28	41.73	42.18	42.64	43.09	43.55	44.00	44.45	44.91

## 15.9 Pressure Equivalents

<i>Note: Use multiplier at convergence of row and column</i>	<b>Kg. Per Sq. Cm.</b>	<b>Lb. Per Sq. In.</b>	<b>Atm.</b>	<b>Bar</b>	<b>In. of Hg.</b>	<b>Kilo-pascals</b>	<b>In. of Water</b>	<b>Ft. of Water</b>
<b>Kg. Per Sq. Cm.</b>	1	14.22	0.9678	0.98067	28.96	98.067	394.05	32.84
<b>Lb. Per Sq. In.</b>	0.07031	1	0.06804	0.06895	2.036	6.895	27.7	2.309
<b>Atm.</b>	1.0332	14.696	1	1.01325	29.92	101.325	407.14	33.93
<b>Bar</b>	1.01972	14.5038	0.98692	1	29.53	100	402.156	33.513
<b>In. of Hg.</b>	0.03453	0.4912	0.03342	0.033864	1	3.3864	13.61	11.134
<b>Kilopascals</b>	0.0101972	0.145038	0.0098696	0.01	0.2953	1	4.02156	0.33513
<b>In. of Water</b>	0.002538	0.0361	0.002456	0.00249	0.07349	0.249	1	0.0833
<b>Ft. of Water</b>	0.03045	0.4332	0.02947	0.029839	0.8819	2.9839	12	1
<i>1 ounce/sq. inch = 0.0625 lbs./sq. inch</i>								

## 15.10 Pressure Conversion—Pounds Per Square Inch to Bar

Pounds Per Square Inch	0	1	2	3	4
	Bar				
0	0.000000	0.068948	0.137895	0.206843	0.275790
10	0.689476	0.758423	0.827371	0.896318	0.965266
20	1.378951	1.447899	1.516847	1.585794	1.654742
30	2.068427	2.137375	2.206322	2.275270	2.344217
40	2.757903	2.826850	2.895798	2.964746	3.033693
50	3.447379	3.516326	3.585274	3.654221	3.723169
60	4.136854	4.205802	4.274750	4.343697	4.412645
70	4.826330	4.895278	4.964225	5.033173	5.102120
80	5.515806	5.584753	5.653701	5.722649	5.791596
90	6.205282	6.274229	6.343177	6.412124	6.481072
100	6.894757	6.963705	7.032652	7.101600	7.170548

Note: To convert to kilopascals, move decimal point two positions to right; to convert to Megapascals, move decimal point one position to left. For example, 30 psi = 2.068427 bar = 206.8427 kPa = 0.2068427 MPa.  
Note: Round off decimal points to provide no more than the desired degree of accuracy.

Pressure Conversion—Pounds Per Square Inch to Bar continued...

Pounds Per Square Inch	5	6	7	8	9
	Bar				
0	0.344738	0.413685	0.482633	0.551581	0.620528
10	1.034214	1.103161	1.172109	1.241056	1.310004
20	1.723689	1.792637	1.861584	1.930532	1.999480
30	2.413165	2.482113	2.551060	2.620008	2.688955
40	3.102641	3.171588	3.240536	3.309484	3.378431
50	3.792117	3.861064	3.930012	3.998959	4.067907
60	4.481592	4.550540	4.619487	4.688435	4.757383
70	5.171068	5.240016	5.308963	5.377911	5.446858
80	5.860544	5.929491	5.998439	6.067386	6.136334
90	6.550019	6.618967	6.687915	6.756862	6.825810
100	7.239495	7.308443	7.377390	7.446338	7.515285

Note: To convert to kilopascals, move decimal point two positions to right; to convert to Megapascals, move decimal point one position to left. For example, 30 psi = 2.068427 bar = 206.8427 kPa = 0.2068427 MPa.  
Note: Round off decimal points to provide no more than the desired degree of accuracy.

## 15.11 Temperature Conversion Formulas

To Covert From	To	Substitute in Formula
Degrees Celsius	Degrees Fahrenheit	$(^{\circ}\text{C} \times 9/5) + 32$
Degrees Celsius	Kelvin	$(^{\circ}\text{C} + 273.16)$
Degrees Fahrenheit	Degrees Celsius	$(^{\circ}\text{F} - 32) \times 5/9$
Degrees Fahrenheit	Degrees Rankin	$(^{\circ}\text{F} + 459.69)$

## 15.12 Temperature Conversions

$^{\circ}\text{C}$	Temp. in $^{\circ}\text{C}$ or $^{\circ}\text{F}$ to be converted	$^{\circ}\text{F}$	$^{\circ}\text{C}$	Temp. in $^{\circ}\text{C}$ or $^{\circ}\text{F}$ to be converted	$^{\circ}\text{F}$	$^{\circ}\text{C}$	Temp. in $^{\circ}\text{C}$ or $^{\circ}\text{F}$ to be converted	$^{\circ}\text{F}$
-273.16	-459.69		-90.00	-130	-202.0	-17.8	0	32.0
-267.78	-450		-84.44	-120	-184.0	-16.7	2	35.6
-262.22	-440		-78.89	-110	-166.0	-15.6	4	39.2
-256.67	-430		-73.33	-100	-148.0	-14.4	6	42.8
-251.11	-420		-70.56	-95	-139.0	-13.3	8	46.4
-245.56	-410		-67.78	-90	-130.0	-12.2	10	50.0
-240.00	-400		-65.00	-85	-121.0	-11.1	12	53.6
-234.44	-390		-62.22	-80	-112.0	-10.0	14	57.2
-228.89	-380		-59.45	-75	-103.0	-8.89	16	60.8
-223.33	-370		-56.67	-70	-94.0	-7.78	18	64.4
-217.78	-360		-53.89	-65	-85.0	-6.67	20	68.0
-212.22	-350		-51.11	-60	-76.0	-5.56	22	71.6
-206.67	-340		-48.34	-55	-67.0	-4.44	24	75.2
-201.11	-330		-45.56	-50	-58.0	-3.33	26	78.8
-195.56	-320		-42.78	-45	-49.0	-2.22	28	82.4
-190.00	-310		-40.00	-40	-40.0	-1.11	30	86.0
-184.44	-300		-38.89	-38	-36.4	0	32	89.6
-178.89	-290		-37.78	-36	-32.8	1.11	34	93.2
-173.33	-280		-36.67	-34	-29.2	2.22	36	96.8
-169.53	-273.16	-459.69	-35.56	-32	-25.6	3.33	38	100.4
-168.89	-272	-457.6	-34.44	-30	-22.0	4.44	40	104.0
-167.78	-270	-454.0	-33.33	-28	-18.4	5.56	42	107.6
-162.22	-260	-436.0	-32.22	-26	-14.8	6.67	44	111.2
-156.67	-250	-418.0	-31.11	-24	-11.2	7.78	46	114.8
-151.11	-240	-400.0	-30.00	-22	-7.6	8.89	48	118.4



## Temperature Conversions continued...

°C	Temp. in °C or °F to be converted	°F	°C	Temp. in °C or °F to be converted	°F	°C	Temp. in °C or °F to be converted	°F
-145.56	-230	-382.0	-28.89	-20	-4.0	10.0	50	122.0
-140.00	-220	-364.0	-27.78	-18	-0.4	11.1	52	125.6
-134.44	-210	-346.0	-26.67	-16	3.2	12.2	54	129.2
-128.89	-200	-328.0	-25.56	-14	6.8	13.3	56	132.8
-123.33	-190	-310.0	-24.44	-12	10.4	14.4	58	136.4
-117.78	-180	-292.0	-23.33	-10	14.0	15.6	60	140.0
-112.22	-170	-274.0	-22.22	-8	17.6	16.7	62	143.6
-106.67	-160	-256.0	-21.11	-6	21.2	17.8	64	147.2
-101.11	-150	-238.0	-20.00	-4	24.8	18.9	66	150.8
-95.56	-140	-220.0	-18.89	-2	28.4	20.0	68	154.4
21.1	70	158.0	204.4	400	752.0	454.4	850	1562.0
22.2	72	161.6	210.0	410	770.0	460.0	860	1580.0
23.3	74	165.2	215.6	420	788.0	465.6	870	1598.0
24.4	76	168.8	221.1	430	806.0	471.1	880	1616.0
25.6	78	172.4	226.7	440	824.0	476.7	890	1634.0
26.7	80	176.0	232.2	450	842.0	482.2	900	1652.0
27.8	82	179.6	237.8	460	860.0	487.8	910	1670.0
28.9	84	183.2	243.3	470	878.0	493.3	920	1688.0
30.0	86	186.8	248.9	480	896.0	498.9	930	1706.0
31.1	88	190.4	254.4	490	914.0	504.4	940	1724.0
32.2	90	194.0	260.0	500	932.0	510.0	950	1742.0
33.3	92	197.6	265.6	510	950.0	515.6	960	1760.0
34.4	94	201.2	271.1	520	968.0	521.1	970	1778.0
35.6	96	204.8	276.7	530	986.0	526.7	980	1796.0
36.7	98	208.4	282.2	540	1004.0	532.2	990	1814.0
37.8	100	212.0	287.8	550	1022.0	537.8	1000	1832.0
43.3	110	230.0	293.3	560	1040.0	543.3	1010	1850.0
48.9	120	248.0	298.9	570	1058.0	548.9	1020	1868.0
54.4	130	266.0	304.4	580	1076.0	554.4	1030	1886.0
60.0	140	284.0	310.0	590	1094.0	560.0	1040	1904.0
65.6	150	302.0	315.6	600	1112.0	565.6	1050	1922.0
71.1	160	320.0	321.1	610	1130.0	571.1	1060	1940.0
76.7	170	338.0	326.7	620	1148.0	576.7	1070	1958.0
82.2	180	356.0	332.2	630	1166.0	582.2	1080	1976.0
87.8	190	374.0	337.8	640	1184.0	587.8	1090	1994.0

*Temperature Conversions continued...*

°C	Temp. in °C or °F to be converted	°F	°C	Temp. in °C or °F to be converted	°F	°C	Temp. in °C or °F to be converted	°F
93.3	200	392.0	343.3	650	1202.0	593.3	1100	2012.0
98.9	210	410.0	348.9	660	1220.0	598.9	1110	2030.0
104.4	220	428.0	354.4	670	1238.0	604.4	1120	2048.0
110.0	230	446.0	360.0	680	1256.0	610.0	1130	2066.0
115.6	240	464.0	365.6	690	1274.0	615.6	1140	2084.0
121.1	250	482.0	371.1	700	1292.0	621.1	1150	2102.0
126.7	260	500.0	376.7	710	1310.0	626.7	1160	2120.0
132.2	270	518.0	382.2	720	1328.0	632.2	1170	2138.0
137.8	280	536.0	387.8	730	1346.0	637.8	1180	2156.0
143.3	290	554.0	393.3	740	1364.0	643.3	1190	2174.0
148.9	300	572.0	398.9	750	1382.0	648.9	1200	2192.0
154.4	310	590.0	404.4	760	1400.0	654.4	1210	2210.0
160.0	320	608.0	410.0	770	1418.0	660.0	1220	2228.0
165.6	330	626.0	415.6	780	1436.0	665.6	1230	2246.0
171.1	340	644.0	421.1	790	1454.0	671.1	1240	2264.0
176.7	350	662.0	426.7	800	1472.0	676.7	1250	2282.0
182.2	360	680.0	432.2	810	1490.0	682.2	1260	2300.0
187.8	370	698.0	437.8	820	1508.0	687.8	1270	2318.0
193.3	380	716.0	443.3	830	1526.0	693.3	1280	2336.0
198.9	390	734.0	448.9	840	1544.0	698.9	1290	2354.0
704.4	1300	2372.0	760.0	1400	2552.0	815.6	1500	2732.0
710.0	1310	2390.0	765.6	1410	2570.0			
715.6	1320	2408.0	771.1	1420	2588.0			
721.1	1330	2426.0	776.7	1430	2606.0			
726.7	1340	2444.0	782.2	1440	2624.0			
732.2	1350	2462.0	787.0	1450	2642.0			
737.8	1360	2480.0	793.3	1460	2660.0			
743.3	1370	2498.0	798.9	1470	2678.0			
748.9	1380	2516.0	804.4	1480	2696.0			
754.4	1390	2534.0	810.0	1490	2714.0			

## 15.13 API and Baumé Gravity Tables and Weight Factors

API Gravity	Baumé Gravity	Specific Gravity	Lb/ U.S. Gravity	U.S. Gal/ Lb	API Gravity	Baumé Gravity	Specific Gravity	Lb/ U.S. Gravity	U.S. Gal/ Lb
0	10.247	1.0760	8.962	0.1116	31	30.78	0.8708	7.251	0.1379
1	9.223	1.0679	8.895	0.1124					
2	8.198	1.0599	8.828	0.1133	32	31.77	0.8654	7.206	0.1388
3	7.173	1.0520	8.762	0.1141	33	32.76	0.8602	7.163	0.1396
4	6.148	1.0443	8.698	0.1150	34	33.75	0.8550	7.119	0.1405
5	5.124	1.0366	8.634	0.1158	35	34.73	0.8498	7.076	0.1413
6	4.099	1.0291	8.571	0.1167	36	35.72	0.8448	7.034	0.1422
7	3.074	1.0217	8.509	0.1175	37	36.71	0.8398	6.993	0.1430
8	2.049	1.0143	8.448	0.1184	38	37.70	0.8348	6.951	0.1439
9	1.025	1.0071	8.388	0.1192	39	38.69	0.8299	6.910	0.1447
10	10.00	1.0000	8.328	0.1201	40	39.68	0.8251	6.870	0.1456
11	10.99	0.9930	8.270	0.1209	41	40.67	0.8203	6.830	0.1464
12	11.98	0.9861	8.212	0.1218	42	41.66	0.8155	6.790	0.1473
13	12.97	0.9792	8.155	0.1226	43	42.65	0.8109	6.752	0.1481
14	13.96	0.9725	8.099	0.1235	44	43.64	0.8063	6.713	0.1490
15	14.95	0.9659	8.044	0.1243	45	44.63	0.8017	6.675	0.1498
16	15.94	0.9593	7.989	0.1252	46	45.62	0.7972	6.637	0.1507
17	16.93	0.9529	7.935	0.1260	47	50.61	0.7927	6.600	0.1515
18	17.92	0.9465	7.882	0.1269	48	50.60	0.7883	6.563	0.1524
19	18.90	0.9402	7.830	0.1277	49	50.59	0.7839	6.526	0.1532
20	19.89	0.9340	7.778	0.1286	50	50.58	0.7796	6.490	0.1541
21	20.88	0.9279	7.727	0.1294	51	50.57	0.7753	6.455	0.1549
22	21.87	0.9218	7.676	0.1303	52	51.55	0.7711	6.420	0.1558
23	22.86	0.9159	7.627	0.1311	53	52.54	0.7669	6.385	0.1566
24	23.85	0.9100	7.578	0.1320	54	53.53	0.7628	6.350	0.1575
25	24.84	0.9042	7.529	0.1328	55	54.52	0.7587	6.316	0.1583
26	25.83	0.8984	7.481	0.1337	56	55.51	0.7547	6.283	0.1592
27	26.82	0.8927	7.434	0.1345	57	56.50	0.7507	6.249	0.1600
28	27.81	0.8871	7.387	0.1354	58	57.49	0.7467	6.216	0.1609
29	28.80	0.8816	7.341	0.1362	59	58.48	0.7428	6.184	0.1617
30	29.79	0.8762	7.296	0.1371	60	59.47	0.7389	6.151	0.1626

## API and Baumé Gravity Tables and Weight Factors continued...

API Gravity	Baumé Gravity	Specific Gravity	Lb/ U.S. Gravity	U.S. Gal/ Lb	API Gravity	Baumé Gravity	Specific Gravity	Lb/ U.S. Gravity	U.S. Gal/ Lb
61	60.46	0.7351	6.119	0.1634	81	80.25	0.6659	5.542	0.1804
62	61.45	0.7313	6.087	0.1643	82	81.24	0.6628	5.516	0.1813
63	62.44	0.7275	6.056	0.1651	83	82.23	0.6597	5.491	0.1821
64	63.43	0.7238	6.025	0.1660	84	83.22	0.6566	5.465	0.1830
65	64.42	0.7201	5.994	0.1668	85	84.20	0.6536	5.440	0.1838
66	65.41	0.7165	5.964	0.1677	86	85.19	0.6506	5.415	0.1847
67	66.40	0.7128	5.934	0.1685	87	86.18	0.6476	5.390	0.1855
68	67.39	0.7093	5.904	0.1694	88	87.17	0.6446	5.365	0.1864
69	68.37	0.7057	5.874	0.1702	89	88.16	0.6417	5.341	0.1872
70	69.36	0.7022	5.845	0.1711	90	89.15	0.6388	5.316	0.1881
71	70.35	0.6988	5.817	0.1719	91	90.14	0.6360	5.293	0.1889
72	71.34	0.6953	5.788	0.1728	92	91.13	0.6331	5.269	0.1898
73	72.33	0.6919	5.759	0.1736	93	92.12	0.6303	5.246	0.1906
74	73.32	0.6886	5.731	0.1745	94	93.11	0.6275	5.222	0.1915
75	74.31	0.6852	5.703	0.1753	95	94.10	0.6247	5.199	0.1924
76	75.30	0.6819	5.676	0.1762	96	95.09	0.6220	5.176	0.1932
77	76.29	0.6787	5.649	0.1770	97	96.08	0.6193	5.154	0.1940
78	77.28	0.6754	5.622	0.1779	98	97.07	0.6166	5.131	0.1949
79	78.27	0.6722	5.595	0.1787	99	98.06	0.6139	5.109	0.1957
80	79.26	0.6690	5.568	0.1796	100	99.05	0.6112	5.086	0.1966

The relation of Degrees Baumé or A.P.I. to Specific Gravity is expressed by the following formulas:

- For liquids lighter than water:

$$\text{Degrees Baumé} = \frac{140}{G} - 130, \quad G = \frac{140}{130 + \text{Degrees Baumé}}$$

$$\text{Degrees A.P.I.} = \frac{141.5}{G} - 131.5, \quad G = \frac{141.5}{131.5 + \text{Degrees A.P.I.}}$$

- For liquids heavier than water:

$$\text{Degrees Baumé} = 145 - \frac{145}{G}, \quad G = \frac{145}{145 - \text{Degrees Baumé}}$$

G = Specific Gravity = ratio of the weight of a given volume of oil at 15.5°C (60°F) to the weight of the same volume of water at 15.5°C (60°F).

The previous tables are based on the weight of 1 gallon (U.S.) of oil with a volume of 231 cubic inches at 15.5°C (60°F) in air at 760 mm pressure and 50% humidity. Assumed weight of 1 gallon of water at 15.5°C (60°F) in air is 8.32828 pounds.

To determine the resulting gravity by mixing oils of different gravities:

$$\blacksquare D = \frac{md_1 + nd_2}{m + n}$$

- D = Density or Specific Gravity of mixture
- m = Proportion of oil of  $d_1$  density
- n = Proportion of oil of  $d_2$  density
- $d_1$  = Specific Gravity of m oil
- $d_2$  = Specific Gravity of n oil ■

## 15.14 Other Useful Conversions

To Covert From	To	Substitute in Formula
Cu Ft (Methane)	B.T.U.	1000 (approx.)
Cu Ft of Water	Lbs of Water	62.4
Degrees	Radians	0.01745
Gals	Lbs of Water	8.336
Grams	Ounces	0.0352
Horsepower (mech.)	Ft Lbs per Min	33,000
Horsepower (elec.)	Watts	746
Kg	Lbs	2.205
Kg per Cu Meter	Lbs per Cu Ft	0.06243
Kilowatts	Horsepower	1.341
Lbs	Kg	0.4536
Lbs of Air (14.7 psia and 60°F)	Cu Ft of Air	13.1
Lbs per Cu Ft	Kg per Cu Meter	16.0184
Lbs per Hr (Gas)	Std Cu Ft per Hr	13.1/Specific Gravity
Lbs per Hr (Water)	Gals per Min	0.002
Lbs per Sec (Gas)	Std Cu Ft per Hr	.41793/Specific Gravity
Radians	Degrees	57.3
Scfh Air	Scfh Propane	0.81
Scfh Air	Scfh Butane	0.71
Scfh Air	Scfh 0.6 Natural Gas	1.29
Scfh	Cu Meters per Hr	0.028317

## 15.15 Metric Prefixes and Suffixes

Multiplication Factor	Prefix	Symbol
$1\ 000\ 000\ 000\ 000\ 000\ 000 = 10^{18}$	exa	E
$1\ 000\ 000\ 000\ 000\ 000 = 10^{15}$	peta	P
$1\ 000\ 000\ 000\ 000 = 10^{12}$	tera	T
$1\ 000\ 000\ 000 = 10^9$	giga	G
$1\ 000\ 000 = 10^6$	mega	M
$1\ 000 = 10^3$	kilo	k
$100 = 10^2$	hecto	h
$10 = 10^1$	deka	da
$0.1 = 10^{-1}$	deci	d
$0.01 = 10^{-2}$	centi	c
$0.001 = 10^{-3}$	milli	m
$0.000\ 001 = 10^{-6}$	micro	$\mu$
$0.000\ 000\ 001 = 10^{-9}$	nano	n
$0.000\ 000\ 000\ 001 = 10^{-12}$	pico	p
$0.000\ 000\ 000\ 000\ 001 = 10^{-15}$	femto	f
$0.000\ 000\ 000\ 000\ 000\ 001 = 10^{-18}$	atto	a



# Index





\*Bold page numbers indicate tables. Italicized page numbers indicate images and diagrams.

## A

**accessory** 26

**actuator** 26, 71, 83, 85

assembly 26

diaphragm 71, 72

direct-acting 18, 71

double-acting 24

electric 73

force calculations 114

level 21

maintenance 165

manual 72, 73

piston 19, 72, 166

rack-and-pinion 73

reverse-acting 19, 20

single-acting 79

sizing 111

globe valve 111

rotary valve 114

spring 16

spring-and-diaphragm 164, 165

stem 16

extension 16

force 16

**actuator and positioner design** 37

**air leakage, instrument** *See* instrument

**air quality, instrument** *See* instrument

**allowable sizing pressure drop**

*See* pressure drop

**American National Standards Institute (ANSI)** 26

**American Petroleum Institute (API)** 26, 169

gravity and weight factors 299, 300

**American Pipe Flange Dimensions** 275

diameter of bolt circles 275

flange diameter 277, 278

flange thickness for flange fittings 278, 279

number of stud bolts and diameter 276, 277

**American Society for Testing and Materials (ASTM)** 26

**American Society of Mechanical Engineers (ASME)** 26, 169

**analog I/P positioner design**

*See* positioner

**angle valve** *See* valve

**ANSI** *See* American National Standards Institute

**approval** *See* standards

**ASME** *See* American Society for Mechanical Engineers

**ASTM** *See* American Society for Testing and Materials

**ATEX ratings** 180

**attenuator** 155

**automatic control system** 26

## B

**backlash** 26

**ball**

full 21

segmented 21, 22, 55

valve 57, 123, 194

V-notch 22, 55, 115

**bar stock valve body** 52

**Baume and API gravity and weight factors** *See* American Petroleum Institute

**bellows seal bonnet** *See* bonnet

**bench set** 23, 167

seating force 167

**Bode diagram** 26

**bolt, tightening** 160

**bonnet** 16, 59

assembly 16, 17

bellows seal 16, 17, 61

extension 18, 60, 141

**booster** See volume booster

**bottom flange** 17

**bushing** 17, 19

**butterfly valve** See valve

**bypass valve** See valve

## C

**cage** 17, 70

characterized 68, 69

equal-percentage 17

linear 17

noise-abatement 123

quick-opening 17

**cage-style**

trim 53

valve body 52

**calculating Cv** 101, 105

**calibration**

curve 26

cycle 26

**capacity** 23, 26

**case, diaphragm** See diaphragm

**cavitation** 116, 118, 121, 141, 142

choked flow 116

valve selection 118

**CEN** See European Committee for Standardization

**characteristic** See flow characteristic

**characterization** 41, 69

**characterized cage** See cage

**characterized valve plug** 69

**check valve** See valve

**clearance flow** 23

**closed loop** See loop

**closure member** 17, 26

guide 17

**coefficients, sizing** See sizing

**control**

loop 15, 26, 96, 147, 152

range 26, 44

system 26

**control valve** See valve

**conventional disk** See disk

**conversion**

mass 294

other 301

pressure 295

temperature 296

**conversions**

mass 294

other 301

pressure 295

temperature 296, 297

**cryogenic service valve** See valve

**customized characteristics** 142

**cylinder** See piston

## D

**deadband** 27, 35, 36

**dead time** 27, 38, 40

**desuperheater**

design 150

fixed-geometry nozzle 150

insertion-style 147

installation 147

self-contained design 151  
 spray penetration 149  
 steam-assisted 152  
 steam-atomized 151, 152  
 variable-geometry nozzle 151, 154

**desuperheating** 147, 148

**diagnostics** *See* positioner

**diaphragm** 17

actuator 17, 71, 72, 164  
 case 17  
 inherent pressure range 24  
 installed pressure range 24  
 plate 18  
 pressure span 23  
 valve *See* valve

**diffuser**

inline 121  
 vent 121

**digital valve controller** 77, 80, 211, 220

diagnostics 77  
 two-way digital communication 78

**dimensions** *See* face-to-face

**direct-acting actuator** *See* actuator

**disk** *See* valve

**double-acting** *See* actuator

**double-ported valve** *See* valve

**dynamic**

time 38  
 torque *See* torque  
 unbalance 24

## E

**eccentric-disk** *See* valve

**eccentric-plug** *See* valve

**effective area** 24

**electric actuator** *See* actuator

**electrical equipment** *See* protection

**electro-hydraulic actuator** *See* actuator

**enclosure rating** 183, 185

**end connections** 57

bolted gasketed flanges 58  
 other 59  
 screwed pipe threads 57  
 welded 58, 59

**engineering data** 224

**enthalpy** 27, 240, 241, 242, 243, 244, 245, 246, 247

**entropy** 27, 240, 241, 242, 243, 244, 245, 246, 247

**equal-percentage** *See* flow characteristic

**equation constants** 99

**Equipment Protection Level (EPL)** 177, 178

**equivalents**

area 293  
 fractional inch to millimeter 290, 291, 292  
 length 289  
 pressure 294  
 volume 293  
 volume rate 293  
 whole inch to millimeter 289

**European Committee for Standardization (CEN)** 169

**European Flange Standards** 170

**European Industrial Valve Standards** 169

**European Material Standards** 170

**European Union (EU) - ATEX Directive 2014/34/EU** 180

**explosion-proof** 181

**extension bonnet** *See* bonnet

**F****face-to-centerline dimensions**

raised-face, globe-style angle valves **92**

**face-to-face dimensions**

butt weld-end, globe-style valves **90, 91**

flanged and flangeless rotary valves **93**

flanged, globe-style valves **88, 89, 90**

high-pressure butterfly valves with offset design **94**

screwed-end, globe-style valves **92**

separable flange, globe-style valves **93**

single-flange and flangeless butterfly valves **94**

socket weld-end, globe-style valves **91, 92**

**fail-closed** 24**fail-open** 24**fail-safe** 24**fault**

detection 162

discrimination 162

**FCI** *See* Fluid Controls Institute**feedback**

control loop 15, 96

signal 27

**final control element** 27, 216, 222**first-order** 27**fixed-gain** *See* positioner**fixed-geometry nozzle**

*See* desuperheater

**flame-proof** 175, 176, 181**flange** 275, 277, 278

bolted gasketed 58

bottom 17

separable 20

**flangeless valve** *See* valve**flashing** 116, 117

choked flow causes 116

valve selection 117

**flow characteristic** 24

customized 142

equal-percentage 27

frequency response 27

inherent 24, 28

installed 24, 29

linear 29

modified parabolic 25

quick-opening 30

selection of 97

**flow coefficient (Cv)** 24

calculating 101, 105

rated 25

relative 25

**Fluid Controls Institute (FCI)** 27, 65, 170**flushing** 161**frequency response** *See* flow characteristic**friction** 28, 36, 112, 113, 126, 127, 164**fugitive emissions** 62, 63**G****gain** 28, 42

inherent valve **29**

installed valve **29, 43**

loop **29, 43**

process **30**

**gate valve** *See* valve**globe valve** 18, 51, 111, 188, 189, 190, 197, 209

cage-style 52, 53

double-ported 53

post- and port-guided 52

single-port 51

three-way 18, 53, 54

**graphite packing** *See* packing

## H

**handwheel** 84

side-mounted 85

top-mounted 85

**hardness** 28

**hazardous location classification** 172

approvals and definitions 172

class and division system 172

equipment groups 174

equipment subgroups 174

zone system 173

**high-capacity valve** *See* valve

**high-pressure valve** *See* valve

**high-recovery valve** *See* valve

**high-temperature valve** *See* valve

**HIPPS (high-integrity pressure protection system)** 221, 222

**hunting** 28

**Hydrocarbons, physical constants of** 234, 235, 236, 237

**hydrodynamic noise prediction**

*See* noise

**hydro trim** *See* trim

**hysteresis** 28

## I

**IEC** *See* International Electrotechnical Commission

**Ingress Protection (IP) codes** 185

**inherent**

characteristic 28, 142

diaphragm pressure range 24

flow characteristic 24

valve gain 29

**inline diffuser** 121

**insertion-style** *See* desuperheater

**installation**

techniques 159

volume booster 79

**installed**

characteristic 24, 42

diaphragm pressure range 24

valve gain 29, 43

**instrument**

air leakage 163

air quality 164

pressure 29

**Instrument Society of America (ISA)** 29, 170

**International Electrotechnical Commission (IEC)** 171, 180

enclosure ratings 183

**intrinsic safety** 175

technique 181

**I/P (current-to-pneumatic)** 29, 76, 77

transducer 78

**ISA** *See* Instrument Society of America

## L

**length equivalents** *See* equivalents

**limit switches** 83

**linear**

cake 17, 68

characteristic 29

**linearity** 29

**loading pressure** *See* pressure

**loop** 26, 29, 96, 147, 152

closed 26, 47

gain 29

open 29

**low-flow valve** *See* valve

**low-recovery valve** *See* valve

## M

### **maintenance**

- actuator 165
- control valve 161
- predictive 162, 163
- preventive 162
- reactive 162

### **manual**

- actuator *See* actuator
- operator *See* handwheel

### **Manufacturers Standardization Society (MSS)** 171

### **materials**

- designations 129
- hardness 28
- non-metallic abbreviations **135**
- packing 62
- specifications 225
- valve body 127, **232**, **233**

**maximum flow rate** *See* flow rate

**maximum rotation** 115

**metric prefixes and suffixes** 302

**microprocessor-based positioner**

*See* positioner

**modified parabolic** *See* flow characteristic

## N

**National Association of Corrosion Engineers (NACE International)** 29, 171

- NACE MR0103 145
- NACE MR0175 144
- Pre-2003 Revisions of NACE MR0175 143

**National Electrical Manufacturer's Association (NEMA)**

enclosure rating 183

**needle valve** *See* valve

### **noise**

- abatement 142
- attenuation 139
- control 120
- prediction 118
  - aerodynamic 118, 120
  - hydrodynamic 120, 123
- summary 123

**non-destructive test procedures** 135

liquid penetrant (surface) examination 136

magnetic particle (surface) examination 135

radiographic (volumetric) examination 136

ultrasonic (volumetric) examination 136

**non-electrical equipment** *See* protection

**non-incendive (or Type n) technique** 182

**non-intrusive diagnostics program** 163

**non-metallic material abbreviations** 135

**normally-closed valve** *See* fail-close

**normally-open valve** *See* fail-open

**nozzle** *See* desuperheater

**nuclear service** *See* valve

## O

**Occupational Safety and Health Administration (OSHA)** 30

**OEM parts** *See* parts

**offset valve** *See* valve

**open loop** 29

**operating medium** 29

**operative limits** 29

**OREDA data** 219

## P

**packing** 19, 30, 62

box (assembly) 18

control valve 61

ENVIRO-SEAL duplex 66, 67

ENVIRO-SEAL graphite 66, 67

ENVIRO-SEAL PTFE 65, 66

friction 112, **113**

graphite ribbon 67

HIGH-SEAL graphite ULF 67

ISO-Seal graphite 67

ISO-Seal PTFE 67

laminated and filament graphite 62

PTFE V-Ring 62, 65

selection 124

for rotary valves **68, 69, 126, 127**

for sliding-stem valves 67, **68, 125, 126**

stem 166

**partial stroke test** 80, 219, 220

**parts**

Original Equipment Manufacturer (OEM) 165

recommended spares 165

service and repair 165

**performance test loop** 34

**pinch valve** *See* valve

**pipe data** 266

**pipe engagement** 267

**pipe threads, screwed** *See* end connection

**pipng geometry factor** 100, 105

**piston** 19

actuator 19, 72

cylinder 17

cylinder closure seal 17

double-acting 72

maintenance 166

**plug guiding** *See* valve plug guiding

**pneumatic positioner** *See* positioner

**port** 19

**port-guided valve** *See* globe valve

**positioner** 30, 75

analog I/P 76, 77

design 37, 76

digital valve controller 77

pneumatic 75

**position transmitter** 83

**post-guided valve** *See* valve

**predictive maintenance** 162, 163

**pressure**

conversion **295**

equivalents **294**

instrument 29

loading 18, 29

range 24

span 23

supply 31, 163

**pressure drop**

allowable sizing 101

ratio factor 105

**pressure-temperature ratings** **130, 131, 132, 133, 134**

**preventive maintenance** 162

**process**

control 25

gain 30

optimization 44

recovery 162

variability 30, 33

**properties of**

- liquid and saturated vapor **240, 241, 242, 243, 244, 245, 246, 247**
- pressure-containing components **232**
- saturated steam **248, 249, 250, 251, 252, 253, 254, 255, 256, 257**
- superheated steam **257, 258, 259, 260, 261, 262, 263, 264, 265**
- water **247, 248**

**protection** 159, 175

- electrical equipment **175**
- Equipment Protection Level (EPL) **177**
- levels of **177**
- non-electrical equipment **176**
- techniques and methods **181**

**push-down-to-close (PDTC) construction** 25**push-down-to-open (PDTO) construction** 25**Q****quick-opening** See flow characteristic**R****rack-and-pinion actuator** 73**range** 24, 26, 30, 44**rangeability** 25**rated**

- flow coefficient **25**
- travel **25**

**reactive maintenance** 162**Refrigerant 717 (Ammonia)** **240, 241, 242, 243, 244, 245, 246, 247****relative flow coefficient** 25**relay** 30

- adjustment **163**

**repeatability** 30**resolution** 30**response**

- time **38**

**response time** 30, 39, 41**restricted-capacity trim** 70**retaining ring** 19**reverse-acting actuator** 19, 20, 71**reverse flow** 22**ring-style attenuator** 155**rod end bearing** 22**rotary actuator sizing** 114**rotary valve** See valve**rubber boot** 19**S****Safety Instrumented System (SIS)** 80, 214, 216

- final control element **216**
- logic solver **216**
- partial stroke test **80**
- safety function and product certification **81**
- sensors **216**
- standards **217**

**Safety Integrity Level (SIL)** 217, 222**saturated steam properties** **248, 249, 250, 251, 252, 253, 254, 255, 256, 257****seal**

- bushing **19**
- cylinder closure **17**
- ring **23**
- sliding **23**

**seat** 19

- leakage **25**
  - allowable **96**
  - classification **95**
- load **19, 112**



- force 112, 167
- recommended **112**
- ring 20
  - maintenance 166
  - replacement 166
- spring 20
- second-order** 30
- segmented ball** *See* valve
- selection**
  - control valve 88
  - flow characteristics 97
  - packing *See* packing
  - valves for cavitation service 118
  - valves for flashing service 117
- sensitivity** 30
- sensor** 30, 216, 221
- separable flange** 20, **93**
- set point** 30
- shaft** 23
  - wind-up 31
- shutoff valve (SOV)** *See* valve
- side-mounted handwheel**
  - See* handwheel
- signal** 31
  - amplitude sequencing (split ranging) 31
  - feedback 27
- silencer** 123
- single-acting positioner** 76, 77
- single-port valve** *See* valve
- sizing** 31, 45, 86, 97
  - abbreviations and terminology **98**
  - actuators
    - for globe valves 111
    - for rotary valves 114
  - coefficients for globe valves **109**
  - coefficients for rotary valves **110**
  - valves
    - for compressible fluids 104
    - for liquids 100
- sliding seal** 23
- sliding-stem**
  - packing *See* packing
  - valve *See* valve
- solenoid valve** 83, 210, 211, 212
- span** 31
- spare parts** 165
- specific heat ratio** 237
- split ranging** 31
- spray penetration** 149
- spring**
  - adjustor 20
  - rate 25
  - seat 20
- spring-and-diaphragm** *See* actuator
- standard flow** 23
- standards** 168
  - cast steel flanges **280**
  - control valve 169
  - European flanges 170
  - European industrial valves 169
  - European materials 170
  - fugitive emissions 63
  - safety 217
- startup trim** *See* trim
- static**
  - friction 31
  - gain 28
  - unbalance 20
- steam attemperator** 155
- steam conditioning valve** 153, 154
- steam sparger** 155
- stem**
  - connector 20

packing  
 maintenance 166

**stiction** 31

**sulfide stress cracking** 143

**superheated steam properties** 257,  
 258, 259, 260, 261, 262, 263, 264, 265

**supply pressure** 31, 40, 163

**swing check valve** *See* valve

## T

**T63** 31

**temperature**

code 178, **179**  
 conversion **296, 297**  
 conversion formulas **296**

**testing**

non-destructive 135  
 online methods 220  
 partial stroke 80, 219, 220  
 techniques 219  
 performance loop 34  
 SIS testing requirements 221

**three-way valve** *See* valve

**time constant** 31

**top-mounted handwheel**

*See* handwheel

**torque**

breakout 114  
 dynamic 114  
 equations 114  
 factors for rotary valves 115

**transducer, I/P** *See* I/P

**travel** 31, 167

deviation 163  
 indicator 31  
 rated 25

**trim** 20, 31, 53, 120

cavitation mitigation 142  
 for flushing, hydro, or start-ups 161  
 noise abatement 142  
 restricted-capacity 70  
 soft-seated 20  
 upgrade considerations 165

**trip**

system 84  
 valve 84

**trunnion mounting** 23

**turbine bypass**

actuation 157  
 components 156  
 system 155  
 valve 156

**two-stage positioner** *See* positioner

**two-way digital communication**

*See* positioner

## U

**unbalance** 111

dynamic 24  
 force 111  
 static 20

**upper valve body** *See* valve

## V

**validation** 162

**valve** 31

accessories 74  
 angle 16  
 assembly 27  
 ball 55, 57, 160, 194  
 bar stock 52  
 body 20, 21

- capacity 26
- bonnet *See* bonnet
- butterfly 54, **94**, 194, 195
  - high-performance 55, 56, **115**
- bypass 156, 192
- cage-style 52
- check 191, 192, 203, 204, **205**, **206**, **207**, **208**, **209**
- conventional disk 22, 190
- cryogenic 141
- diaphragm 193
  - straightway-type 193
  - weir-type 193
- double-port 53
- eccentric disk 22
- eccentric plug 22, 56
- end connection *See* end connection
- flangeless 22
- full-port ball 57
- functions and characteristics terminology 23
- gain 28, 29, 43
  - inherent 29
  - installed 29
- gate 187, 188
- globe *See* globe valve
- high-capacity 139
- high-recovery 24
- high-temperature 140
- installation techniques 159
- low flow 140
- low-recovery 24
- maintenance 158, 161
- materials *See* materials
- multi-port 57, 195
- needle 190
- normally-closed 25
- normally-open 25
- nuclear 142
- offset 18
- packing *See* packing
- performance 32, 36
- pinch 193
- plug 21
  - characterized 69
- post- and port-guided 52
- protection 159, 175, 177
- response time 38, **39**
- rotary 22
- sanitary 54
- selection 117, 118
- single-port 51 *See* globe valve
- sizing 31
- sliding-stem 15, 16, 73, **125**
- solenoid 83, 211, 212
- special 121, 138, 140
- standards *See* standards
- steam conditioning 153
- stem 21, 166
- storage 159
- style 44, 51
- swing check *See* valve: check
- three-way 53
- travel 31, 167
- trip 84
- turbine bypass 156
- type 41, 187
  - unbalance areas 111
  - V-notch ball 22, 55, **115**
- valve body** *See* valve
- valve plug guiding** 70
  - cage-guiding 70
  - port-guiding 70
  - stem-guiding 70
  - top- and bottom-guiding 70

top-guiding 70

**valve sizing** 97

for compressible fluids 104

for liquids 100

**vena contracta** 25, 116

**vent diffuser** 121

**V-notch ball** See valve

**volume booster** 31, 78, 79

**volume equivalents** 293

**volume rate equivalents** 293

## W

**wafer** 94, 195

geometry-assisted 152

**welded end connection** 58, 59

**wireless position monitor** 83

**wiring practices** 179

## Y

**yoke** 21, 72

## Z

**zero error** 31

**zone system** 173, 178, 179



# Appendix

## Additional Resources



## **Sourcebooks**

*Industry overviews and best practices for control valve assemblies*

## **Technical Documentation**

*Detailed specifications for valves, actuators, & instruments*

## **White Papers**

*Process control industry and application expertise*

## **Other**