

X20(c)AO2437

1 General information

The module is equipped with 2 current outputs with 16-bit digital converter resolution. The 2 channels are electrically isolated from each other. The user can select between the 3 output ranges 4 to 20 mA, 0 to 20 mA and 0 to 24 mA.

- 2 analog current outputs
- Electrically isolated analog channels
- 16-bit digital converter resolution

2 Coated modules

Coated modules are X20 modules with a protective coating for the electronics component. This coating protects X20c modules from condensation and corrosive gases.

The modules' electronics are fully compatible with the corresponding X20 modules.

For simplification purposes, only images and module IDs of uncoated modules are used in this data sheet.

The coating has been certified according to the following standards:

- Condensation: BMW GS 95011-4, 2x 1 cycle
- Corrosive gas: EN 60068-2-60, method 4, exposure 21 days



3 Order data

Model number	Short description	Figure
	Analog outputs	
X20AO2437	X20 analog output module, 2 outputs, 4 to 20 mA / 0 to 20 mA or 0 to 24 mA, 16-bit converter resolution, single channel electrically isolated	
X20cAO2437	X20 analog output module, coated, 2 outputs, 4 to 20 mA / 0 to 20 mA or 0 to 24 mA, 16-bit converter resolution, single channel electrically isolated	
	Required accessories	
	Bus modules	
X20BM11	X20 bus module, 24 VDC keyed, internal I/O supply continuous	
X20BM15	X20 bus module, with node number switch, 24 VDC keyed, internal I/O supply continuous	
X20cBM11	X20 bus module, coated, 24 VDC keyed, internal I/O supply continuous	
	Terminal blocks	
X20TB12	X20 terminal block, 12-pin, 24 VDC keyed	

Table 1: X20AO2437, X20cAO2437 - Order data

4 Technical data

Model number	X20AO2437	X20cAO2437
Short description		
I/O module	2 analog outputs 4 to 20 mA, 0 to 20 mA or 0 to 24 mA	
General information		
B&R ID code	0xB785	0xE1F2
Status indicators	I/O function per channel, operating state, module status	
Diagnostics		
Module run/error	Yes, using status LED and software	
Outputs	Yes, using status LED and software	
Power consumption		
Bus	0.05 W	
Internal I/O	1.6 W	
Additional power dissipation caused by actuators (resistive) [W]	-	
Certifications		
CE	Yes	
KC	Yes	-
UL	cULus E115267 Industrial control equipment	
HazLoc	cCSAus 244665 Process control equipment for hazardous locations Class I, Division 2, Groups ABCD, T5	
ATEX	Zone 2, II 3G Ex nA nC IIA T5 Gc IP20, Ta (see X20 user's manual) FTZÜ 09 ATEX 0083X	
DNV GL	Temperature: B (0 - 55°C) Humidity: B (up to 100%) Vibration: B (4 g) EMC: B (Bridge and open deck)	
LR	ENV1	
GOST-R	Yes	
Analog outputs		
Output	4 to 20 mA, 0 to 20 mA or 0 to 24 mA, configurable using software	
Digital converter resolution	16-bit	
Settling time for output changes over entire range	2 ms to 20 s, configurable using software	
Data output rate	1 ms without ramp	
Max. error at 25°C		
Gain		
4 to 20 mA	0.025% ¹⁾	
0 to 20 mA	0.022% ¹⁾	
0 to 24 mA	0.02% ¹⁾	
Offset		
4 to 20 mA	0.025% ²⁾	
0 to 20 mA	0.022% ²⁾	
0 to 24 mA	0.02% ²⁾	
Output protection	Short circuit protection, overvoltage protection (up to 30 VDC)	
Open-circuit detection	Yes, using hardware and software	
Data format	INT	
Output format		
4 to 20 mA	INT 0x0000 to 0x7FFF / 1 LSB = 0x0001 = 762.94 nA	
0 to 20 mA	INT 0x0000 bis 0x7FFF / 1 LSB = 0x0001 = 610.352 nA UINT 0x0000 to 0xFFFF / 1 LSB = 0x0001 = 305.176 nA	
0 to 24 mA	INT 0x0000 to 0x5DC0 / 1 LSB = 0x0001 = 1000 nA	
Load per channel	Max. 600 Ω	
Short-circuit proof	Yes, continuous	
Output filter	Active 2nd-order low pass / cutoff frequency 4 kHz Configurable slew rate	
Max. gain drift		
4 to 20 mA	0.0055 %/°C ¹⁾	
0 to 20 mA	0.005 %/°C ¹⁾	
0 to 24 mA	0.005 %/°C ¹⁾	
Max. offset drift		
4 to 20 mA	0.0035 %/°C ²⁾	
0 to 20 mA	0.002 %/°C ²⁾	
0 to 24 mA	0.002 %/°C ²⁾	
Error caused by load change ³⁾		
4 to 20 mA	0.14%	
0 to 20 mA	0.1%	
0 to 24 mA	0.1%	
Nonlinearity	<0.003% ⁴⁾	

Table 2: X20AO2437, X20cAO2437 - Technical data

Model number	X20AO2437	X20cAO2437
Test voltage between		
Channel and channel		1000 VAC
Channel and bus		1000 VAC
To ground		1000 VAC
Electrical characteristics		
Electrical isolation	Channel isolated from channel and bus	
Operating conditions		
Mounting orientation		
Horizontal		Yes
Vertical		Yes
Installation elevation above sea level		
0 to 2000 m	No limitations	
>2000 m	Reduction of ambient temperature by 0.5°C per 100 m	
Degree of protection per EN 60529	IP20	
Environmental conditions		
Temperature		
Operation		
Horizontal mounting orientation	-25 to 60°C	
Vertical mounting orientation	-25 to 50°C	
Derating	See section "Derating"	
Storage	-40 to 85°C	
Transport	-40 to 85°C	
Relative humidity		
Operation	5 to 95%, non-condensing	Up to 100%, condensing
Storage	5 to 95%, non-condensing	
Transport	5 to 95%, non-condensing	
Mechanical properties		
Note	Order 1x X20TB12 terminal block separately Order 1x X20BM11 bus module separately	Order 1x X20TB12 terminal block separately Order 1x X20cBM11 bus module separately
Spacing	12.5 ^{+0.2} mm	

Table 2: X20AO2437, X20cAO2437 - Technical data

- 1) Based on the current output value.
- 2) Based on the respective output range
- 3) Load change from 1 Ω → 600 Ω, resistive
- 4) Based on the entire output range.

5 LED status indicators

For a description of the various operating modes, see section "Additional information - Diagnostic LEDs" of the X20 system user's manual.

Figure	LED	Color	Status	Description
	Operating status			
	r	Green	Off	No power to module
			Single flash	UNLINK mode
			Double flash	BOOT mode (during firmware update) ¹⁾
			Blinking quickly	SYNC mode
			Blinking slowly	PREOPERATIONAL mode
			On	RUN mode
			Flickering (approx. 10 Hz)	Module is in OSP mode
	Module status			
	e	Red	Off	No power to module or everything OK
			Single flash	A conversion error has occurred. When an error occurs, the LED of the faulty analog output channel begins to double flash and this status is output.
			On	Error or reset status
	Analog output			
	1 - 2	Orange	Off	Indicates one of the following cases: <ul style="list-style-type: none"> • No power to module • Channel disabled
			Single flash	Open line
		Double flash	A conversion error has occurred. A single flash is output on the red "e" module status LED.	
		On	Digital/analog converter running, value OK	

- 1) Depending on the configuration, a firmware update can take up to several minutes.

6 Pinout

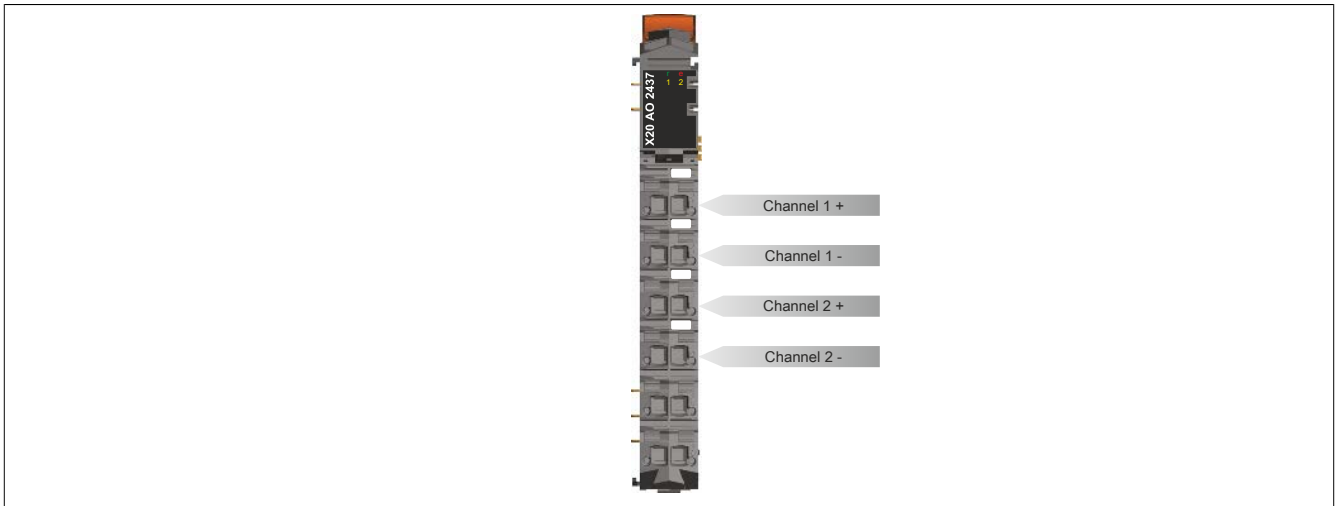

7 Connection example

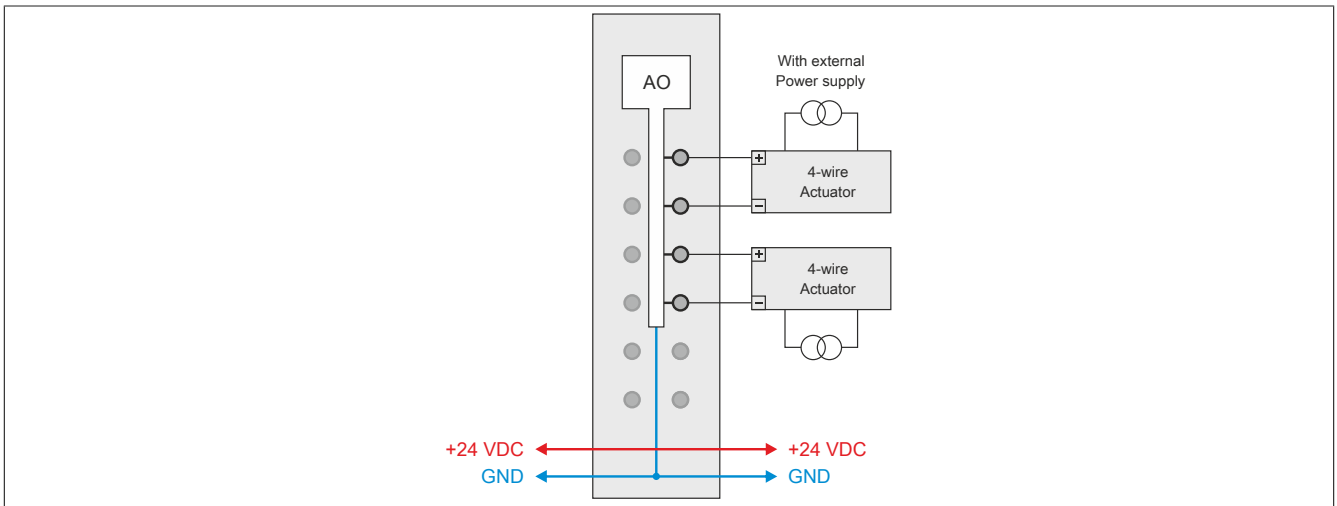

8 OSP hardware requirements

In order to best use OSP mode, make sure when creating the application that the output module and CPU have separate power supplies.

9 Output circuit diagram

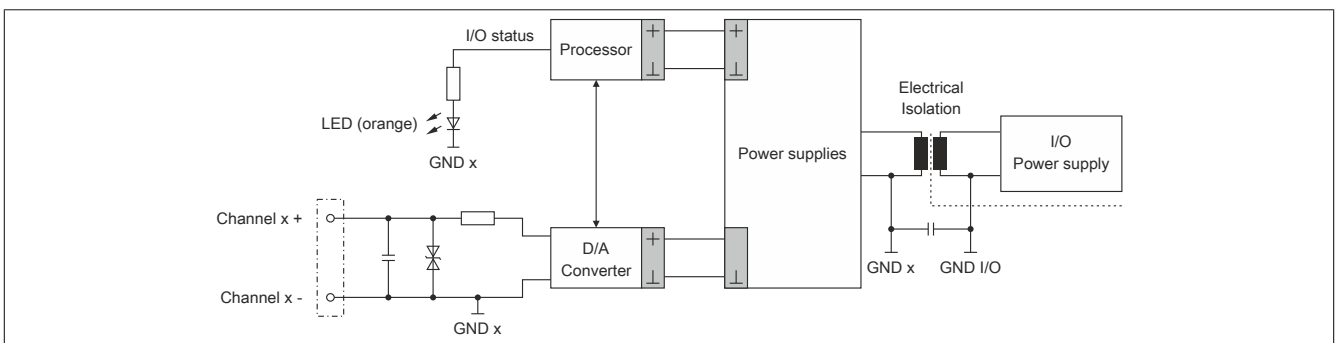

10 Derating

To ensure proper operation, the derating values listed below must be adhered to:

Horizontal installation

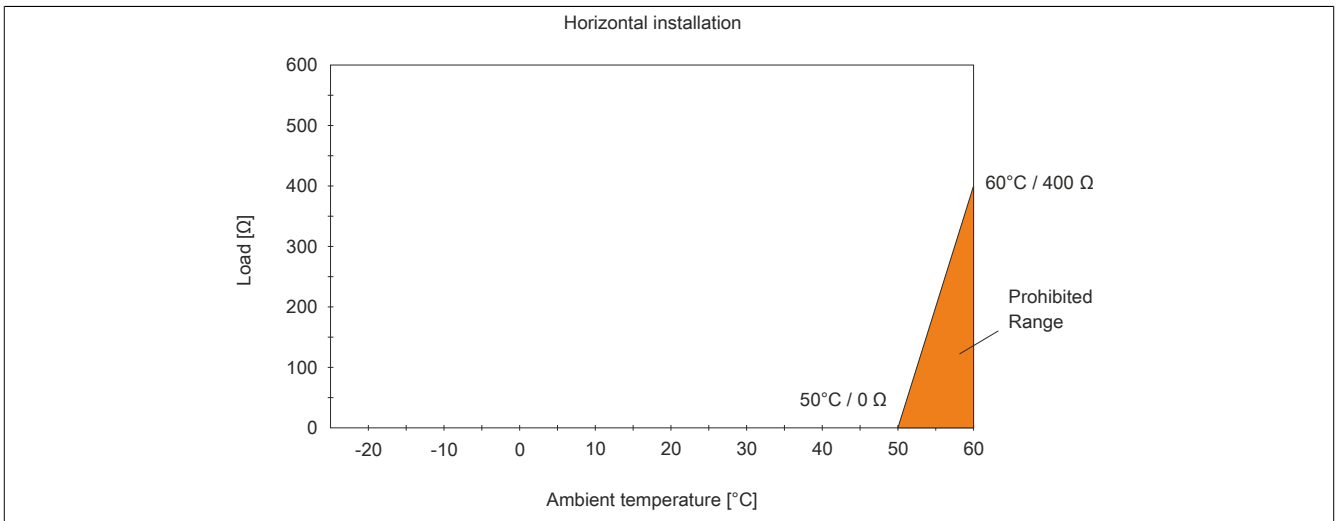

Figure 1: Derating the load with horizontal mounting

Vertical installation

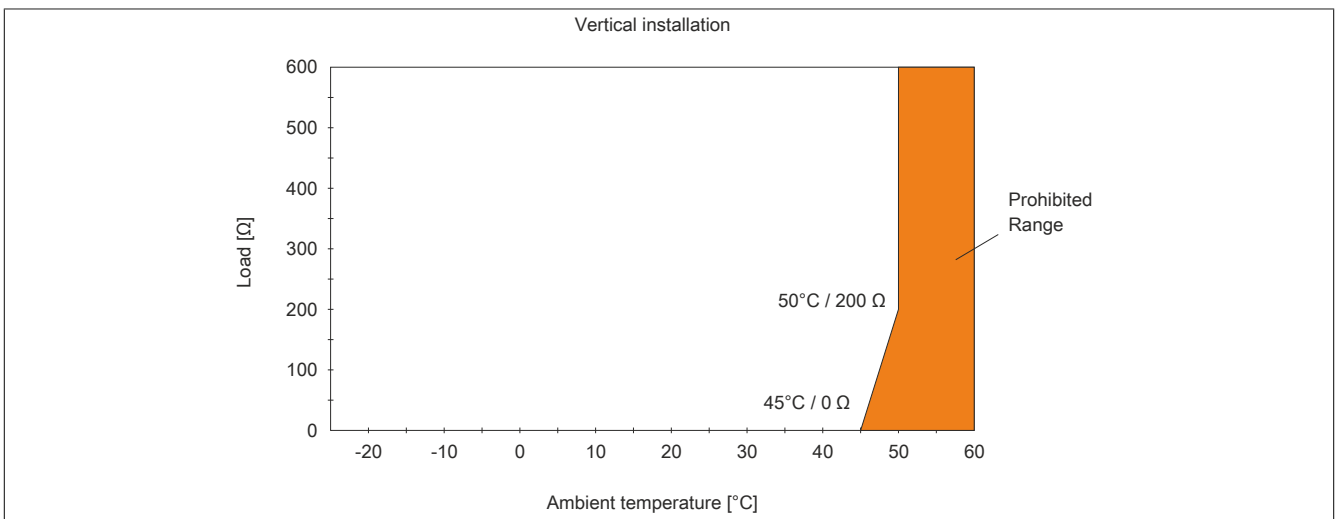

Figure 2: Derating the load with vertical mounting

11 Register description

11.1 General data points

In addition to the registers listed in the register description, the module also has other more general data points. These registers are not specific to the module but contain general information such as serial number and hardware version.

General data points are described in section "Additional information - General data points" of the X20 system user's manual.

11.2 Function model 0 - Standard

Register	Name	Data type	Read		Write	
			Cyclic	Non-cyclic	Cyclic	Non-cyclic
Analog signal - Configuration						
386 394	AnalogMode01 AnalogMode02	UINT				•
390 398	DACSlewrate01 DACSlewrate02	UINT				•
Analog signal - Communication						
0 2	AnalogOutput01 AnalogOutput02	(U)INT			•	
30 31	AnalogStatus01 AnalogStatus02	USINT	•			
	OpenLineAnalogOutput01 or OpenLineAnalogOutput02	Bit 2				
	ConversionErrorAnalogOutput01 or ConversionErrorAnalogOutput02	Bit 3				
	IoSuppErrorAnalogOutput01 or IoSuppErrorAnalogOutput02	Bit 7				

11.3 Function model 1 - OSP

Register	Name	Data type	Read		Write	
			Cyclic	Non-cyclic	Cyclic	Non-cyclic
Analog signal - Configuration						
386 394	AnalogMode01 AnalogMode02	UINT				•
390 398	DACSlewrate01 DACSlewrate02	UINT				•
Analog signal - Communication						
0 2	AnalogOutput01 AnalogOutput02	(U)INT			•	
30 31	AnalogStatus01 AnalogStatus02	USINT	•			
	OpenLineAnalogOutput01 or OpenLineAnalogOutput02	Bit 2				
	ConversionErrorAnalogOutput01 or ConversionErrorAnalogOutput02	Bit 3				
	IoSuppErrorAnalogOutput01 or IoSuppErrorAnalogOutput02	Bit 7				
The OSP function model						
32	OSPComByte	USINT			•	
	OSPValid	Bit 0				
401 403	CfgOSPMODE01 CfgOSPMODE02	USINT				•
34 36	CfgOSPValue01 CfgOSPValue02	INT				•

11.4 Function model 254 - Bus controller

Register	Offset ¹⁾	Name	Data type	Read		Write	
				Cyclic	Non-cyclic	Cyclic	Non-cyclic
Analog signal - Configuration							
386 394	-	AnalogMode01 AnalogMode02	UINT				•
390 398	-	DACSlewwrate01 DACSlewwrate02	UINT				•
Analog signal - Communication							
0 2	0 2	AnalogOutput01 AnalogOutput02	(U)INT			•	
30 31	-	AnalogStatus01 AnalogStatus02	USINT		•		
		OpenLineAnalogOutput01 or OpenLineAnalogOutput02	Bit 2				
		ConversionErrorAnalogOutput01 or ConversionErrorAnalogOutput02	Bit 3				
		IoSuppErrorAnalogOutput01 or IoSuppErrorAnalogOutput02	Bit 7				

1) The offset specifies the position of the register within the CAN object.

11.4.1 Using the module on the bus controller

Function model 254 "Bus controller" is used by default only by non-configurable bus controllers. All other bus controllers can use other registers and functions depending on the fieldbus used.

For detailed information, see section "Additional information - Using I/O modules on the bus controller" of the X20 user's manual (version 3.50 or later).

11.4.2 CAN I/O bus controller

The module occupies 1 analog logical slot on CAN I/O.

11.5 Analog signal - Configuration

The module has 2 electrically isolated channels. All registers have a dual design. Channels can be configured and operated independently of one another.

Specific features

- Electrical isolation by channel
- Configurable output ramp DAC slew rate (Default: 210 ms full scale)

11.5.1 AnalogMode

Name:

AnalogMode01 to AnalogMode02

These registers are used to predefine the operating parameters that the module will be using for the respective channel. Each channel must be activated and configured separately.

Information:

When you select the operating mode "Scaling 0 to 20 mA (Resolution 0 to 65535)", then the corresponding "AnalogOutput" registers are interpreted internally as UINT instead of INT.

The entire program must be rebuilt for the data type change to take effect. The data type cannot be changed during runtime (e.g. using a library).

Data type	Values	Bus controller default setting
UINT	See the bit structure.	33

Bit structure:

Bit	Name	Value	Information
0	Channel	0	Disabled
		1	Enabled (bus controller default setting)
1	Check - D/A converter configuration/status	0	Enabled (bus controller default setting)
		1	Disabled
2 - 3	Reserved	-	
4	Scaling 0 to 20 mA (Resolution 0 to 32767)	0	Disabled
		1	Enabled
5	Scaling 4 to 20 mA (Resolution 0 to 32767)	0	Disabled
		1	Enabled (bus controller default setting)
6	Scaling 0 to 24 mA (Resolution 0 to 24000)	0	Disabled
		1	Enabled
7	Scaling 0 to 20 mA (Resolution 0 to 65535)	0	Disabled
		1	Enabled
8 - 15	Reserved	-	

11.5.2 DACSlewwrate

Name:

DACSlewwrate01 to DACSlewwrate02

These registers limit the rate at which the analog signal is modified. This makes it possible to define a sort of upper limit frequency.

The following formula applies: $f(\text{Analog}) = f(\text{Output rate}) * \text{Permitted change} / \max. \Delta(\text{standardized output value})$

Data type	Values	Bus controller default setting
UINT	See the bit structure.	514

Bit structure:

Bit	Name	Value	Information
0 - 2	Permitted change per rate	000	1-bit
		001	2-bit
		010	4-bit (bus controller default setting)
		011	8-bit
		100	16-bit
		101	32-bit
		110	64-bit
		111	128-bit
3 - 7	Reserved	-	
8 - 11	Output rate	0000	257730 Hz
		0001	198410 Hz
		0010	152440 Hz (bus controller default setting)
		0011	131580 Hz
		0100	115740 Hz
		0101	69440 Hz
		0110	37590 Hz
		0111	25770 Hz
		1000	20160 Hz
		1001	16030 Hz
		1010	10290 Hz
		1011	8280 Hz
		1100	6900 Hz
		1101	5530 Hz
		1110	4240 Hz
		1111	3300 Hz
12 - 14	Reserved	-	
15	Slewwrate enable (ramp functionality)	0	Disabled (undefined jump behavior)
		1	Enabled (defined transitions)

11.6 Analog signal - Communication

In order to output the desired current signal (default: 4 to 20 mA), the module must be provided with the normalized output value (default: 0 to 32767).

11.6.1 AnalogOutput

Name:

AnalogOutput01 to AnalogOutput02

These registers provide the normalized output values. Depending on the scaling selected (see register "[Analog-Mode](#)" on page 8), the range of values and the data type can be adapted to the requirements of the application. Once a permissible value is transferred, the module outputs the corresponding current.

Information:

The value "0" disables the channel status LED.

Data type	Value
INT	0 to 32767
Optional: UINT	0 to 65535

11.6.2 AnalogStatus

Name:

AnalogStatus01 to AnalogStatus02

The status register gives the user feedback about whether the respective channel is functioning properly.

Data type	Value
USINT	See bit structure

Bit structure:

Bit	Name	Value	Information
0 - 1	Reserved	-	
2	OpenLineAnalogOutput01, 02	0	Line OK
		1	Open line
3	ConversionErrorAnalogOutput01, 02	0	Conversion temperature OK
		1	Conversion temperature too high
4 - 6	Reserved	-	
7	IoSuppErrorAnalogOutput01, 02	0	Module supply OK
		1	Module supply error

11.7 "OSP" function model

In the "OSP" function model (Operator Set Predefined), the user defines an analog value or digital pattern. This OSP value is output as soon as communication between the module and master is interrupted.

Functionality

The user can choose between 2 OSP modes:

- Retain last valid value
- Replace with static value

In the first case, the module retains the last value as validly recognized output state.

When selecting the mode, "Replace with static value" a plausible output value must be entered in the corresponding value register. If an OSP event occurs, this value will be output instead of the value currently requested by the task.

11.7.1 Activating the OSP output in the module

Name:

OSPValid

This data point offers the possibility to start module output and request OSP operation during running operation.

Data type	Values
USINT	See the bit structure.

Bit structure:

Bit	Name	Value	Information
0	OSPValid	0	Request OSP operation (after initial start or module in Standby)
		1	Request normal operation
1 - 7	Reserved	0	

There is one OSPValid bit on the module, which is managed by the user task. It must be set when the enabled channels are started. As long as the OSPValid bit remains set in the module, the module behaves the same as the "Standard" function model.

If an OSP event occurs (e.g. communication between the module and master CPU interrupted) then the OSPValid bit will be reset on the module. The module enters OSP mode and the output occurs in the "[OSPMode](#)" on [page 12](#) register according to the configuration.

The following applies:

The OSP replacement value remains even after the communication channel has recovered. OSP mode is only exited when a set OSPValid bit is transferred.

When the master CPU is restarted, the OSPValid bit is re-initialized on the master CPU. It must once more be set by the application and transferred via the bus.

When temporary communication errors occur between the module and master CPU (e.g. due to EMC), a few bus cycles will pass without refreshing the cyclic registers. The OSPValid bit is reset internally in the module - the bit in the CPU however remains set. Upon the next successful transfer, the OSPValid bit in the module is set again and the module returns to normal operation.

The ModulOK bit can be evaluated if the task in the master CPU needs to know which output mode the module is currently in.

Warning!

If the OSPValid bit is reset to "0" on the module, then the output state no longer depends on the relevant task in the master CPU. However, an output still occurs depending on the configuration of the OSP replacement value.

11.7.2 Setting the OSP mode

Name:

CfgOSPMode01 to CfgOSPMode02

This register essentially controls a channel's behavior when OSP is being used.

Data type	Value	Description
USINT	0	Replace with static value
	1	Retain last valid value

11.7.3 Define the OSP analog output value

Name:

CfgOSPValue01 to CfgOSPValue02

This register contains the analog output value, which is output in "Replace with static value" mode during OSP operation.

Data type	Value
Corresponds to AnalogOutput0x	Corresponds to AnalogOutput0x

Warning!

The "OSPValue" is not accepted by the module until the "OSPValid" bit has been set in the module.

11.8 Minimum cycle time

The minimum cycle time defines how far the bus cycle can be reduced without communication errors occurring. It is important to note that very fast cycles reduce the idle time available for handling monitoring, diagnostics and acyclic commands.

Minimum cycle time
200 μ s

11.9 Minimum I/O update time

The minimum I/O update time defines how far the bus cycle can be reduced while still allowing an I/O update to take place in each cycle.

Minimum I/O update time
200 μ s