

GuardPLC Digital Input Module

Catalog Number 1753-IB16

Topic	Page
Important User Information	2
About the Module	3
General Safety	3
Install the Module	4
Mount the Module	5
Ground the Module	5
Wire the Module	6
Make Connections for Safety-related Communication	10
Reset Push Button	10
Status Indicators	11
Specifications	12
Additional Resources	14

Important User Information

Solid-state equipment has operational characteristics differing from those of electromechanical equipment. Safety Guidelines for the Application, Installation and Maintenance of Solid State Controls (Publication SGI-1.1 available from your local Rockwell Automation sales office or online at <http://www.rockwellautomation.com/literature/>) describes some important differences between solid-state equipment and hard-wired electromechanical devices. Because of this difference, and also because of the wide variety of uses for solid-state equipment, all persons responsible for applying this equipment must satisfy themselves that each intended application of this equipment is acceptable.

In no event will Rockwell Automation, Inc. be responsible or liable for indirect or consequential damages resulting from the use or application of this equipment.

The examples and diagrams in this manual are included solely for illustrative purposes. Because of the many variables and requirements associated with any particular installation, Rockwell Automation, Inc. cannot assume responsibility or liability for actual use based on the examples and diagrams.

No patent liability is assumed by Rockwell Automation, Inc. with respect to use of information, circuits, equipment, or software described in this manual.

Reproduction of the contents of this manual, in whole or in part, without written permission of Rockwell Automation, Inc., is prohibited.

Throughout this manual, when necessary, we use notes to make you aware of safety considerations.

	WARNING: Identifies information about practices or circumstances that can cause an explosion in a hazardous environment, which may lead to personal injury or death, property damage, or economic loss.
	ATTENTION: Identifies information about practices or circumstances that can lead to personal injury or death, property damage, or economic loss. Attentions help you identify a hazard, avoid a hazard and recognize the consequences.
	SHOCK HAZARD: Labels may be on or inside the equipment, for example, drive or motor, to alert people that dangerous voltage may be present.
	BURN HAZARD: Labels may be on or inside the equipment, for example, drive or motor, to alert people that surfaces may reach dangerous temperatures.
IMPORTANT	Identifies information that is critical for successful application and understanding of the product.

About the Module

The 1753-IB16 digital input module is a 16-channel input module for use with GuardPLC controllers.

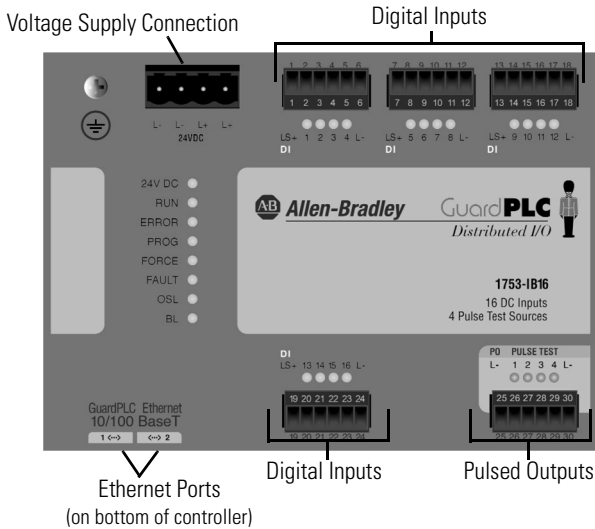

General Safety



ATTENTION: Personnel responsible for the application of safety-related programmable electronic systems (PES) shall be aware of the safety requirements in the application of the system and shall be trained in using the system.

Preventing Electrostatic Discharge



ATTENTION: This equipment is sensitive to electrostatic discharge, which can cause internal damage and affect normal operation. Follow these guidelines when you handle this equipment:

- Touch a grounded object to discharge static potential.
- Wear an approved wrist-strap grounding device.
- Do not touch connectors or pins on component boards.
- Do not touch circuit components inside the equipment.
- Use a static-safe workstation, if available.
- Store the equipment in appropriate static-safe packaging when not in use.

Environment and Enclosure



ATTENTION: This equipment is intended for use in a Pollution Degree 2 industrial environment, in overvoltage Category II applications (as defined in IEC publication 60664-1), at altitudes up to 2000 m (6562 ft) without derating.

This equipment is considered Group 1, Class A industrial equipment according to IEC/CISPR 11. Without appropriate precautions, there may be difficulties with electromagnetic compatibility in residential and other environments due to conducted as well as radiated disturbances.

This equipment is supplied as open-type equipment. It must be mounted within an enclosure that is suitably designed for those specific environmental conditions that will be present and appropriately designed to prevent personal injury resulting from accessibility to live parts. The enclosure must have suitable flame-retardant properties to prevent or minimize the spread of flame, complying with a flame spread rating of 5VA, V2, V1, V0 (or equivalent) if non-metallic. The interior of the enclosure must be accessible only by the use of a tool. Subsequent sections of this publication may contain additional information regarding specific enclosure type ratings that are required to comply with certain product safety certifications.

In addition to this publication, see:

- Industrial Automation Wiring and Grounding Guidelines, Rockwell Automation publication [1770-4.1](#), for additional installation requirements.
 - NEMA 250 and IEC 60529, as applicable, for explanations of the degrees of protection provided by different types of enclosure.
-

Install the Module

Follow these steps to install the module.

1. Mount the module to a DIN rail.
2. Ground the module.
3. Wire the module.
4. Make connections for safety-related communication.

This publication describes these steps in detail.

Mount the Module

IMPORTANT For effective cooling, mount the module following these guidelines.

- Mount the module horizontally.
- Provide a gap of at least 100 mm (3.94 in.) above and below the module.
- Select a location where air flows freely or use an additional fan.
- Do not mount the module over a heating device.

The module cannot be panel-mounted. Mount the module to a DIN rail by following these steps.

1. Hook the top slot over the DIN rail.
2. Insert a flathead screwdriver into the gap between the housing and the latch and pull the latch downward.
3. Hold the latch down as you push the housing back onto the DIN rail.
4. Release the latch to lock the module onto the rail.

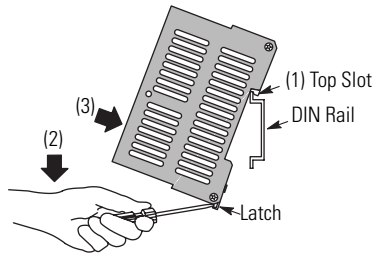

TIP To remove the module from the DIN rail, insert a flathead screwdriver into the gap between the housing and the latch and pull the latch downward as you lift the module off of the rail.

Ground the Module

The module is functionally grounded through its DIN rail connection. A protective earth ground connection is required and is provided through a separate grounding screw on the upper left of the housing and marked with the grounding symbol ⊕.

You must also provide an acceptable grounding path for each device in your application. For more information on proper grounding guidelines, refer to the *Industrial Automation Wiring and Grounding Guidelines*, publication [1770-4.1](#).



ATTENTION: This product is grounded through the DIN rail to chassis ground. Use zinc-plated yellow-chromate steel DIN rail to assure proper grounding. The use of other DIN rail materials (for example, aluminum or plastic) that can corrode, oxidize, or are poor conductors, can result in improper or intermittent grounding. Secure DIN rail to mounting surface approximately every 200 mm (7.8 in.) and use end-anchors appropriately.

Wire the Module

The following sections describe how to connect the voltage supply and connect the inputs and outputs.

Connect the Voltage Supply

To comply with CE Low Voltage Directives (LVD) and UL restrictions, you must use either a Safety Extra Low Voltage (SELV), or a Protected Extra Low Voltage (PELV) power supply to power this module. A SELV supply cannot exceed 30V rms, 42.4V peak, or 60V DC under normal conditions and under single-fault conditions. A PELV supply has the same rating and is connected to protected earth.

IMPORTANT Protect the module with a 4 A slow-blow fuse.

The supply voltage is connected via a 4-pin connector that accommodates wire sizes up to 2.5 mm² (14 AWG). You need to connect only one wire to L+ and one wire to L-. Both L+ and L- terminals are internally connected, so you can daisy-chain 24V DC power from the module to other devices in the panel by using the remaining terminal.



ATTENTION: Do not reverse the L+ and L- terminals or damage to the module will result. There is no reverse polarity protection.

Safety-related Digital Inputs

The module has 16 digital inputs (DI1...DI16) and 4 pulsed test-sources (PO1...PO4) whose status is indicated via status indicators.

LS+ is a voltage source that provides 24V DC for a group of four dry contact inputs. There are four groups on the module.

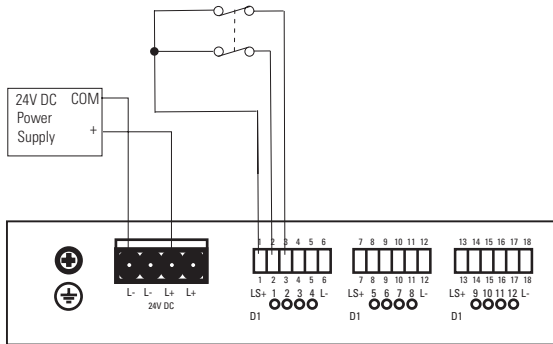

Connection of Voltage Supply to Input Device

If devices require 24V DC to operate and use the same power source as the module, then wire the outputs of the device directly to inputs on the module.

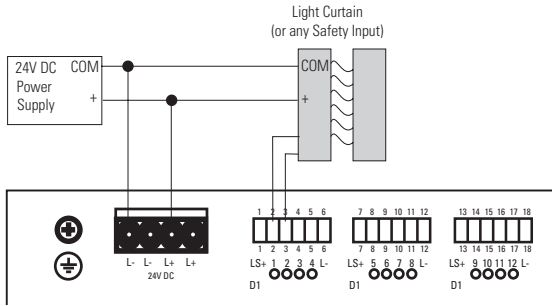

Connection of Voltage Supply to Input Device

Devices with their own dedicated power supply can also be connected. Connect the reference pole of the external power supply to the L- reference pole of the input.

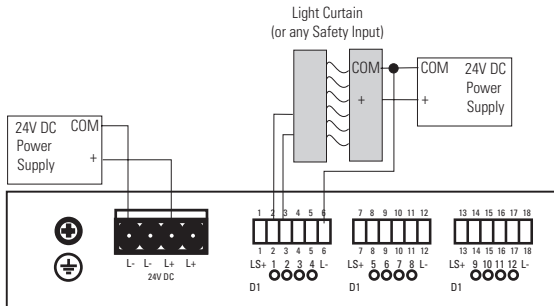

Connection of Devices with Dedicated Power Supplies

The safe state of an input is indicated by a 0 signal being passed to the user program. If the test routines detect a fault in the digital inputs, a 0 signal is processed in the user program for the defective channel. When a fault occurs, the inputs are switched off (0) and the FAULT indicator is activated.

Follow the closed-circuit principle for external wiring when connecting sensors. To create a safe state in the event of a fault, the input signals revert to the de-energized state (0). Although the external line is not monitored, a wire break is interpreted as a safe (0) signal.

Digital Input Terminals

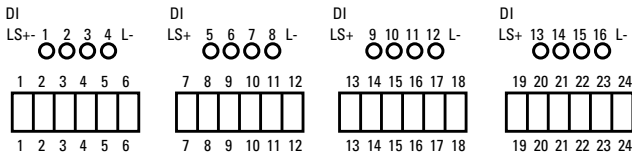

Terminals accommodate wires up to 1.5 mm² (16 AWG). See the terminal torque specifications on page 12. Digital inputs (DI) are connected to the following terminals.

Terminal Number	Designation	Function
1	LS+	Sensor supply for inputs 1...4
2	1	Digital input 1
3	2	Digital input 2
4	3	Digital input 3
5	4	Digital input 4
6	L-	Reference pole
7	LS+	Sensor supply for inputs 5...8
8	5	Digital input 5
9	6	Digital input 6
10	7	Digital input 7
11	8	Digital input 8
12	L-	Reference pole
13	LS+	Sensor supply for inputs 9...12
14	9	Digital input 9
15	10	Digital input 10
16	11	Digital input 11
17	12	Digital input 12
18	L-	Reference pole
19	LS+	Sensor supply for inputs 13...16
20	13	Digital input 13
21	14	Digital input 14
22	15	Digital input 15
23	16	Digital input 16
24	L-	Reference pole

LS+, not L+, should be used for short-circuit protection. Each LS+ features individual short-circuit and EMC protection that make it important to use LS+ for only its four related inputs.

Line Control

Line control is a short-circuit and line-break monitoring system, for example, E-stop inputs that are configured for the 1753-IB16 system.

For line control, the device has four digital pulse test sources (PO) connected to the following terminals.

Terminal Number	Designation	Function
25	L-	Reference pole
26	1	Pulsed source 1
27	2	Pulsed source 2
28	3	Pulsed source 3
29	4	Pulsed source 4
30	L-	Reference pole

The example below shows two pulse test sources connected to the digital inputs (DI) of the same system. As a result, the connections to the digital inputs (DI) are monitored.

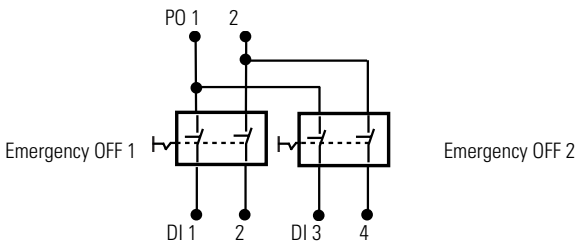

Inputs are set to 0, a fault code is generated, and the FAULT status indicator is on when:

- a short-circuit occurs between two parallel connections.
- two connections are reversed.
- earth fault occurs on one of the lines (only with earthed reference pole).
- a line breaks or one of the contacts opens (that is, when one of the E-stop off switches is pressed in the example above).

IMPORTANT For information on how to configure inputs and pulse test sources for line control, see the GuardPLC Controller Systems User Manual, publication [1753-UM001](#).

Make Connections for Safety-related Communication

The module has two 10/100BaseT, RJ45 connectors on the bottom of the unit, that provide communication to the GuardPLC controller via GuardPLC Ethernet protocol. Because this is an Ethernet switch, you can daisy-chain connections from the GuardPLC module to other distributed I/O modules. The switch is auto-detect. Either crossover or straight-through cabling can be used. Star or line configurations are available. Make sure that a network loop is not generated. Data packets must be able to reach a node only via a single path.

The media access control (MAC) address of the module can be found on the label positioned over both lower RJ45 connections.

A transparent label shipped with the module can be used to note the IP address and system ID (SRS).

IMPORTANT If you attach the label to the module, make sure you do not cover any of the ventilation slots.

Reset Push Button

The module is equipped with a reset push button. Reset via the push button is necessary under the following conditions.

- You forget the password to go online via the programming software.
- You are unable to determine the IP address and SRS of the controller.

The push button is accessible through a small round hole at the top of the housing, approximately 4...5 cm (1.6...2.0 in.) from the left rim and recessed approximately 9.5 mm (0.375 in.).

IMPORTANT Activate the reset push button using an insulated pin to prevent short-circuits.

To reset, press and hold the push button for 20 seconds while rebooting the device by cycling power. Pressing the Reset push button during operation has no effect.

With activation of the reset button:

- all accounts are deleted except for the default account.
- IP Address and System ID (SRS) are set to their default values.

The next time you cycle power, these settings will be restored to the last values stored in nonvolatile memory. This means that either the settings prior to the reset will be restored, or if any settings were changed after the reset, those new settings will still be in effect.

Status Indicators

Indicator	State	Descriptin
24V DC	On	24V DC operating voltage present.
	Off	No operating voltage.
RUN	On	This is the normal status of the controller. A routine, which has been loaded into the controller, is executed. The controller processes input and output signals, carries out communication, and performs hardware and software tests.
	Flashing	The controller is in STOP mode and is not executing a routine. All system outputs are reset. STOP mode can be triggered by setting the <i>Emergency stop</i> system variable to TRUE in the routine, or by direct command from the programming software.
	Off	The controller is in ERROR_STOP mode (see ERROR).
ERROR	On	<ul style="list-style-type: none"> • A hardware error has been detected by the controller. The controller goes to ERROR_STOP mode and the execution of the routine is halted. Hardware errors are errors in the controller, errors in one or more of the digital input and output modules, or errors in the counters. • A software error in the operating system has been detected by the controller. • The watchdog has reported an error due to exceeded cycle time. All system outputs will be reset and the controller ceases all hardware and software tests. The controller can only be restarted by a command from the programming software.
	Off	No errors are detected.
PROGRESS	On	The upload of a new controller configuration is in progress.
	Flashing	The upload of a new operating system into the nonvolatile ROM is in progress.
	Off	No upload of controller configuration or operating system in progress.
FORCE	On	The controller is executing a routine (RUN) and FORCE mode is activated by the user.
	Flashing	The controller is in STOP mode, but Forcing has been initiated, and will be activated when the controller is started.
	Off	Forcing is OFF.
FAULT	On	<ul style="list-style-type: none"> • The routine (logic) has caused an error. • The controller configuration is faulty. • The upload of a new operating system was not successful and the operating system is corrupted.
	Flashing	An error has occurred during a nonvolatile ROM write cycle. One or more I/O errors have occurred.
	Off	None of the above errors has occurred.
OSL	Flashing	Emergency O perating S ystem L oader is active.
BL	Flashing	B oot L oader unable to load operating system or unable to start COMM operating system loader.

Module status can be interrogated through the programming software. For more information, refer to the GuardPLC System User Manual, publication [1753-UM001](#).

Specifications

Technical Specifications – 1753-IB16 Module

Attribute	1753-IB16
Interfaces: GuardPLC Ethernet	2 x RJ45, 10/100BaseT (with 100 Mbit/s) with integrated switch
Operating voltage	24V DC, -15...20%, w_{ss} 15% from a power supply with protective separation, conforming to IEC 61131-2 requirements
Isolation voltage	50V (continuous), Basic Insulation Type, I/O to Ethernet and Ethernet to DC power
Wiring category ⁽¹⁾	Category 2 on communication ports, signal ports, and power ports
Wire size	<ul style="list-style-type: none"> I/O – 0.13...1.3 mm² (26...16 AWG) solid or stranded copper wire rated at 75 °C (167 °F) or greater with 1.2 mm (3/64 in.) insulation max Power – 0.33...2.1 mm² (22...14 AWG) solid or stranded copper wire rated at 75 °C (167 °F) or greater with 1.2 mm (3/64 in.) insulation max Ethernet – RJ45 connector according to IEC 60603-7, 2 or 4 pair Category 5e minimum cable according to TIA 568-B.1, or Category 5 cable according to ISO/IEC 24702
Wire type	Shielded on Ethernet
Terminal block torque	0.51 N•m (4.5 lb•in)
Fuse (external)	24V DC power: 10 A (time-lag)
Response time	≥ 10 ms
Battery backup	None
Current consumption	0.8 A max (with max load), 0.4 A idle current
Enclosure type rating	Meets IP20
Width, approx.	152 mm (5.99 in.) including housing screws
Height, approx.	114 mm (4.49 in.) including latch
Depth, approx.	66 mm (2.60 in.) including grounding bolt
Weight, approx.	0.7 kg (1.54 lb)

Digital Inputs

Number of inputs	16 (not electrically isolated)
1 Signal	Voltage: 15...30V DC, Current consumption: ≥ 2 mA @ 15V
0 Signal	Voltage: 5V DC max, Current consumption: 1.5 mA max (1 mA @ 5V)
Switching point	Typically 7.5V
Switching time	Typically 250 μs
Sensor supply	4 x 19.2V / 40 mA @ 24V short-circuit proof

(1) Use this Conductor Category information for planning conductor routing. Refer to Industrial Automation Wiring and Grounding Guidelines, publication [1770-4.1](#).

Environmental Specifications – 1753-IB16 Module

Attribute	1753-L28BBB-M, 1753-L28BBB-P
Temperature, nonoperating <ul style="list-style-type: none"> • IEC 60068-2-1 (Test Ab, Unpackaged nonoperating cold) • IEC 60068-2-2 (Test Bb, Unpackaged nonoperating dry heat) • IEC 60068-2-14 (Test Na, Unpackaged nonoperating thermal shock) 	-40...85 °C (-40...185 °F)
Temperature, operating <ul style="list-style-type: none"> • IEC 60068-2-1 (Test Ad, operating cold) • IEC 60068-2-2 (Test Bd, operating dry heat) • IEC 60068-2-14 (Test Nb, operating thermal shock) 	0...60 °C (32...140 °F)
Temperature, surrounding air	60 °C (140 °F)
Vibration <ul style="list-style-type: none"> • IEC 60068-2-6 (Test Fc, operating) 	1 g @ 10...150 Hz
Shock, operating <ul style="list-style-type: none"> • IEC 60068-2-27 (Test Ea, unpackaged shock) 	15 g
Relative humidity <ul style="list-style-type: none"> • IEC 60068-2-30 (Test Db, unpackaged damp heat) 	10...95% noncondensing
Emissions	CISPR 11: Group 1, Class A
ESD Immunity <ul style="list-style-type: none"> • IEC 61000-4-2 	<ul style="list-style-type: none"> • 6 kV contact discharges • 8 kV air discharges
Radiated RF Immunity <ul style="list-style-type: none"> • IEC 61000-4-3 	<ul style="list-style-type: none"> • 10V/m with 1kHz sine-wave 80% AM from 80 MHz...2000 MHz • 1 V/m with 1 kHz sine-wave 80% AM from 2000...2700 MHz
EFT/B Immunity <ul style="list-style-type: none"> • IEC 61000-4-4 	<ul style="list-style-type: none"> • ±2 kV @ 5 kHz on DC power ports • ±1 kV @ 5 kHz on signal ports • ±1 kV @ 5 kHz on communication ports
Surge Transient Immunity <ul style="list-style-type: none"> • IEC 61000-4-5 	<ul style="list-style-type: none"> • ±500V line-line (DM) and ±500V line-earth (CM) on DC power ports • ±1 kV line-earth (CM) on signal ports • ±1 kV line-earth (CM) on communication ports
Conducted RF Immunity <ul style="list-style-type: none"> • IEC 61000-4-6 	10V rms with 1 kHz sine-wave 80% AM from 150 kHz...80 MHz
Damped Oscillatory Wave Immunity <ul style="list-style-type: none"> • IEC 61000-4-12 	<ul style="list-style-type: none"> • ±1 kV line-earth (CM) on signal ports • ±1 kV line-earth (CM) on power ports

Certifications

Certification (when product is marked) ⁽¹⁾	1753-IB16
c-UL-us	UL Listed Industrial Control Equipment, certified for US and Canada. See UL File E65584.
CE	European Union 2004/108/EC EMC Directive, compliant with: <ul style="list-style-type: none"> • EN 61326-1 Meas./Control/Lab., Industrial Requirements • EN 61000-6.2; Industrial Immunity • EN 61000-6-4; Industrial Emissions • EN 61131-2; Programmable Controllers (Clause 8, Zone A & B)
C-Tick	Australian Radiocommunications Act, compliant with: AS/NZS CISPR 11; Industrial Emissions
Functional Safety	Certified by TÜV ⁽²⁾ : up to and including SIL 3 according to IEC 61508 and PL (Cat. 4) according to ISO 13849-1

(1) See the Product Certification link at <http://www.ab.com> for Declarations of Conformity, Certificates, and other certification details.

(2) When used with specified firmware revisions.

Additional Resources

The table below provides a listing of publications that contain important information about GuardPLC systems.

Resource	Description
GuardPLC Controller Systems Safety Reference Manual, publication 1753-RM002	Detailed information regarding the safety certification of the GuardPLC System
GuardPLC Controller Systems User Manual, publication 1753-UM001	Detailed information on installing, wiring, configuring, operating, maintaining, and troubleshooting GuardPLC systems
Using RSLogix Guard PLUS! Software with GuardPLC Controllers Programming Manual, publication 1753-PM001	Detailed information on programming your GuardPLC system using RSLogix Guard PLUS! software
Industrial Automation Wiring and Grounding Guidelines, publication 1770-4.1	General guidelines for installing a Rockwell Automation industrial system

You can view or download publications at <http://www.rockwellautomation.com/literature>. To order paper copies of technical documentation, contact your local Rockwell Automation distributor or sales representative.

Rockwell Automation Support

Rockwell Automation provides technical information on the Web to assist you in using its products. At <http://www.rockwellautomation.com/support/>, you can find technical manuals, a knowledge base of FAQs, technical and application notes, sample code and links to software service packs, and a MySupport feature that you can customize to make the best use of these tools.

For an additional level of technical phone support for installation, configuration and troubleshooting, we offer TechConnect support programs. For more information, contact your local distributor or Rockwell Automation representative, or visit <http://www.rockwellautomation.com/support/>.

Installation Assistance

If you experience a problem within the first 24 hours of installation, please review the information that's contained in this manual. You can also contact a special Customer Support number for initial help in getting your product up and running.

United States or Canada	1.440.646.3434
Outside United States or Canada	Use the Worldwide Locator at http://www.rockwellautomation.com/support/americas/phone_en.html , or contact your local Rockwell Automation representative.

New Product Satisfaction Return

Rockwell Automation tests all of its products to ensure that they are fully operational when shipped from the manufacturing facility. However, if your product is not functioning and needs to be returned, follow these procedures.

United States	Contact your distributor. You must provide a Customer Support case number (call the phone number above to obtain one) to your distributor to complete the return process.
Outside United States	Please contact your local Rockwell Automation representative for the return procedure.

Documentation Feedback

Your comments will help us serve your documentation needs better. If you have any suggestions on how to improve this document, complete this form, publication [BA-DU002](#), available at <http://literature.rockwellautomation.com>.

Allen-Bradley, Rockwell Software, Rockwell Automation, and GuardPLC are trademarks of Rockwell Automation, Inc.

Trademarks not belonging to Rockwell Automation are property of their respective companies.

Rockwell Otomasyon Ticaret A.Ş., Kar Plaza İş Merkezi E Blok Kat:6 34752 İçerenköy, İstanbul, Tel: +90 (216) 5698400

www.rockwellautomation.com

Power, Control and Information Solutions Headquarters

Americas: Rockwell Automation, 1201 South Second Street, Milwaukee, WI 53204 USA, Tel: (1) 414.382.2000, Fax: (1) 414.382.4444

Europe/Middle East/Africa: Rockwell Automation, Vorstlaan/Boulevard du Souverain 36, 1170 Brussels, Belgium, Tel: (32) 2 663 0600, Fax: (32) 2 663 0640

Asia Pacific: Rockwell Automation, Level 14, Core F, Cyberport 3, 100 Cyberport Road, Hong Kong, Tel: (852) 2887 4788, Fax: (852) 2508 1846

Rockwell Automation Publication 1753-IN004C-EN-P - June 2010

PN-77079

Supersedes Publication 1753-IN004B-EN-P - March 2004

Copyright © 2010 Rockwell Automation, Inc. All rights reserved. Printed in the U.S.A.